

D. (Luft) T. 2190 A-8

For Official Use Only!

# Fw 190 A-8

## Aircraft Handbook

Fliegertechnische Schule 4/Dv.-Stelle	
L. G. Rdo <i>R</i>	
zugewiesen lt.: I. <i>4</i> / Dv. Nr. <i>5338</i> / <i>44</i>	
Vereinnehm t	
am <i>7. 12. 44</i>	Einmahme: Beleg Nr.: <i>1744</i> / <i>44</i>
Prüfnummer: <i>632</i> <i>Hopp</i>	

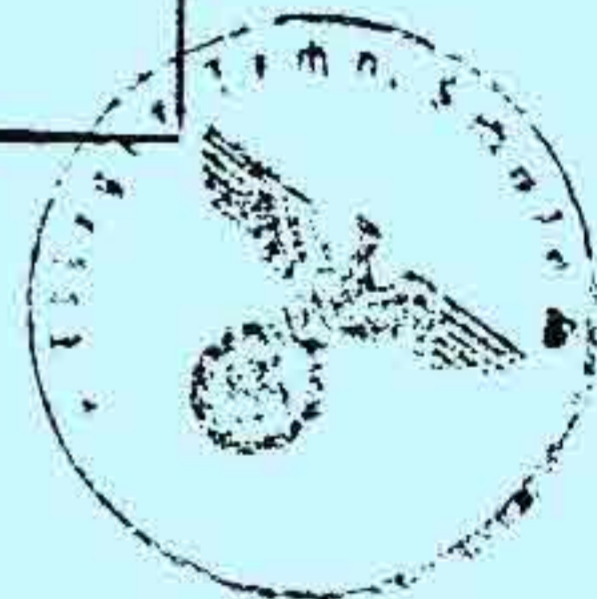

(Effective July 1944)

Issued September 1944

# Aircraft handbook contents

- Part 0    General**
- Part 1    Fuselage**
- Part 2    Undercarriage**
- Part 3    Control unit assembly**
- Part 4    Flight controls**
- Part 5    Wing assembly**
- Part 6    Powerplant**
- Part 7    Engine operating and fuel supply system**
- Part 8 A    Armament installation**  
**Supplement 1: A-8/R1**
- Part 8 B    Bomb release system**
- Part 8 C    Special weapons system**
- Part 8 D    Special fittings**
- Part 8 E    Camera system**
- Part 9 A    General equipment**  
**Supplement 1: PKS 12 Patin directional control**
- Part 9 B    Radio installation**

Luftwaffe High Command

Berlin, 5 September 1944

Chief of Technical Services  
Nr. 280513/44 (E\*Ste. Re. E2V)

I hereby approve D.(Luft) T.2190A-8 -- "Fw 190A-8  
Aircraft handbook (Effective July 1944) Issued  
September 1944."

It is in effect from the date of issue.

By order  
Wittmer

To reduce the preparation time of the Fw 190A-8 technical handbooks, the artists have used some drawings originally prepared for earlier marks of this aircraft. Where there are points of difference between them and the Fw 190A-8, they are marked with an asterisk (\*). See the general arrangement drawings attached as Annex A to Part 0 to resolve any differences.

D. (Luft) T. 2190 A-8

For Official Use Only!

# **Fw 190 A-8**

Aircraft Handbook

**Part 0**

**General**

**(Effective July 1944)**

**Issued September 1944**

# I. General data

## A. Specifications

### 1. Purpose

The Fw 190A-8 is a single-seat fighter aircraft possessing both a high top speed and good maneuverability. It can also be employed as a fighter-bomber carrying bombs, or as an extended range fighter carrying an underfuselage drop tank.

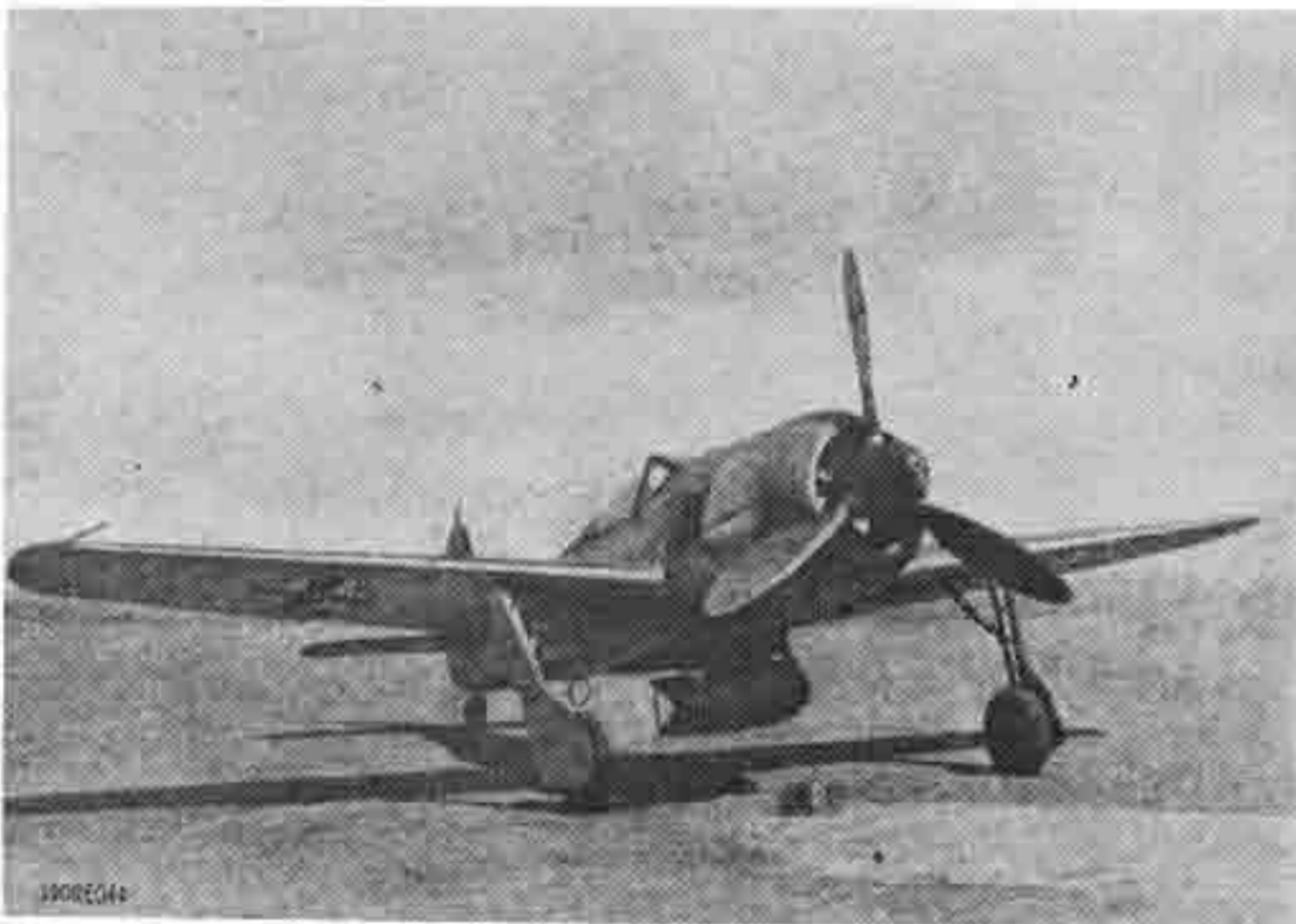

Fig. 1: General view

### 2. Type of construction

The aircraft is a single-engined, cantilever low-wing monoplane, of all-metal construction, with a single vertical tail and retractable undercarriage.

### 3. Airframe

#### a. Fuselage

The fuselage is composed of a Dural covering over a monocoque frame. At its forward end it is of circular cross-section to match the shape of the powerplant. At the rear end it is of oval cross-section. It comprises two major subsections, the forward fuselage (firewall to bulkhead 8) and the rear fuselage (bulkhead 8 to bulkhead 14).

The engine bearer assembly is attached to the firewall (bulkhead 1). The cockpit and fuel tanks are housed in the forward fuselage. In an emergency, the cockpit canopy can be jettisoned by the actuation of an explosive charge.

Armour plating protects the pilot against enemy fire.

An equipment bay, accessible through a hinged cover, is located in the rear fuselage. A fabric bulkhead, also located in the aft fuselage, prevents the sucking of engine exhaust fumes forward into the cockpit.

#### b. Undercarriage

The undercarriage consists of a two strut main gear unit and a tailwheel. The tailwheel can be swivelled through 360° and can be locked into position.

Undercarriage actuation is electrical; operation is monitored electrically, by an undercarriage position indicator, and mechanically, by an indicator rod.

The main undercarriage members are attached to the main spar, retracting inwards. When retracted, they are completely stored within apertures in the wing leading edge and are fully covered by fairings and covers.

During undercarriage retraction, the tailwheel is pulled up and held in place by a cable attached to the radius rod hinge point on the right undercarriage leg. The lower half of the tailwheel remains exposed after retraction, serving, in that position, as an emergency tail skid.

#### c. Control surfaces

The horizontal and vertical tail surfaces are positioned centrally on the tail unit; the ailerons, outboard on the wing trailing edge. The landing flaps are positioned inboard of the ailerons on the wing lower rear surface.

#### d. Flying controls

Elevators and ailerons are actuated by the pilot's control stick; the rudder by foot pedals. Movement of the controls is accomplished through cables, DUZ flexible push-rods and bellcranks. Through differential gears built into the elevator and rudder controls, the stick forces are kept to a minimum close to the neutral positions of these surfaces. Recently, in place of the rudder control differential bellcrank, a torsion bar fixture (without differential movement) has been installed.

The horizontal stabilizer and flaps are electrically actuated. Synchronized movement of the flap drive motors is accomplished through synchronizing switches.

## e. Wing unit

The wing is of one piece construction. The main spar is continuous, the rear spar is divided by the fuselage. Wings and fuselage are connected at both the main and rear spars.

Monocoque type construction. The main spar forms part of the lower shell; the rear spar, part of the upper.

## 4. Powerplant

## a. Engine

BMW 801D air cooled, 14-cylinder twin row radial engine with two speed supercharger, reduction gearing and engine cooling fan.

A control unit (Kommandogerät) automatically adjusts and monitors airscrew RPM, boost pressure, fuel mixture, ignition timing adjustment and supercharger switchover.

## b. Airscrew

Three bladed adjustable airscrew with constant speed unit. In case of the failure of the automatic adjustment controls, or of the engine, the blades can be electrically positioned by a thumb actuated manual switch.

Airscrew diameter is 3,30 m (10'10").

## c. Tanks

Fuel tanks: Two self-sealing fuselage tanks with a total capacity of 524 Liters (115.5 gal). Forward tank 232 Liters (51 gal), rear tank 292 Liters (64.5 gal).

A drop tank of 300 Liter (66.2 gal) capacity can be carried on an ETC 501 rack beneath the fuselage.

Oil tank: A circular tank, protected by an armoured nose ring, with a capacity of 55 Liters (12.1 gal).

An armoured ring also protects the oil cooler.

Hydraulic fluid tank (for control unit): The engine mounting ring serves as container. Capacity 5,6 Liters (4.94 qt).

Primer fuel tank: Built into the rear fuel tank. Capacity 3 Liters (2.64 qt).

Behind bulkhead 8 there is also provision for the installation of a GM-1 tank, 85 Liter (18.7 gal) capacity, or an auxiliary fuel tank, 115 Liter (25.3 gal) capacity.

## 5. Equipment

## a. Radio equipment

FuG 25a -- IFF transponder unit  
FuG 16ZY -- Air-to-air and air-to-ground VHF communications and homing set

## b. Built-in armament

Fuselage: 2 x MG 131  
Wing-roots: 2 x MG 151/20E  
Wings: 2 x MG 151/20E

## c. Armament modifications

Various weapons installations are available; the changes apply to the wing mounted weapons only. The sub-designations are as follows:

A-8/R1	2 x 2 MG 151/20E
A-8/R2	2 MK 108
A-8/R3	2 MK 103

## B. Aircraft data

### 1. General measurements

## Dimensions:

Span .....	10,50 m (34'5½")
Overall length .....	8,95 m (29'4½")
Height .....	3,95 m (12'11½")

## Wings:

Span .....	10,50 m (34'5½")
Maximum chord .....	2,30 m (7'6")
Wing area .....	18,30 sq m (196.6 sq ft)

## Control surfaces:

Horizontal tail area ...	2,73 sq m (29.4 sq ft)
Vertical tail area .....	1,56 sq m (16.8 sq ft)
Aileron area .....	1,93 sq m (20.7 sq ft)
Flap area .....	1,69 sq m (18.2 sq ft)

## Undercarriage:

Track .....	3,50 m (11'6")
Main tire dimensions ...	700 x 175
Tail tire dimensions ...	350 x 135 or 380 x 150
Mainwheel rims .....	VDM/8-2090 B-2 or A-3; VDM/8-2061 A-1
Tailwheel rims .....	KPZ/8-3512 B-2 or A-2
Mainwheel brakes .....	hydraulic
Gear retraction .....	electro-mechanical

## 2. Engine performance

a. Rated altitude (without dynamic air pressure) supercharger low settings:

	Altitude ft	Power hp	Speed RPM	Boost psi
Take-off and emergency power (3 min max)	1970	1705	2700	20.2
Climb and combat power (30 min)	2300	1500	2400	18.7
Maximum endurance cruise	3940	1350	2300	17.0
Maximum economy cruise	5900	1045	2100	15.6 lean

b. Rated altitude (without dynamic air pressure) supercharger high settings:

	Altitude ft	Power hp	Speed RPM	Boost psi
Take-off and emergency power (3 min max)	18,700	1420	2700	20.2
Climb and combat power (30 min)	17,400	1300	2400	18.7
Maximum endurance cruise	18,000	1165	2300	17.0
Maximum economy cruise	17,700	970	2100	15.6 lean

II: Fighter operations with 2 MG 131s, 4 MG 151/20Es and Increased range

III: Fighter-bomber operations with 2 MG 131s, 4 MG 151/20Es, and ETC 501

IV: Fighter-bomber operations with 2 MG 131s, 4 MG 151/20Es, ETC 501 with 4 ETC 50B-1s or 50L-2s on ER-4 adapter

For mission types I and II, 21-cm rocket launchers and also the additional fuselage fuel tank can be installed.

Mission type	I	II	III	IV
Weight in lbs.				
Empty weight	6750	6750	6750	6750
Additional equipment	858	1050	990	1160
Empty equipped weight	7608	7800	7740	7910
Pilot	222	222	222	222
Fuel, forward (51.1 gal)	402	402	402	402
Fuel, rear (64.4 gal)	504	504	504	504
Drop tank (66.2 gal)	---	516	---	---
Oil (12.1 gal)	111	111	111	111
Ammunition MG 131 (2 x 450 rounds)	170	170	170	170
Ammunition MG 151/20E (wing-roots)(2 x 250 rounds)	243	243	243	243
Ammunition MG 151/20E (outboard)(2 x 140 rounds)	137	137	137	137
Disposable weight on ETC 501	---	---	1140	650
Winter-emergency equipment	55	55	55	55
Loaded weight	9452*	10160*	10724***	10404**

## 3. Flight performance

For detailed data see the Flight performance tables.

## 4. Weight data

Mission type:

I: Fighter operations with 2 MG 131s and 4 MG 151/20Es

\* When 21-cm projectiles and launchers are installed, the aircraft weight is increased by 624 lbs.

\*\* When the 4 50L-2 releases are fitted to the ER-4 adapter, aircraft weight is decreased by 71 lbs.

\*\*\* At this take-off weight, the tires are overloaded. Use increased tire pressure (see Part 2) and take off only from a paved runway or hard, even field.

With the additional fuselage fuel tank, 115 Ltr (25.3 gal) installed, the aircraft weight is increased by about 265 lbs.

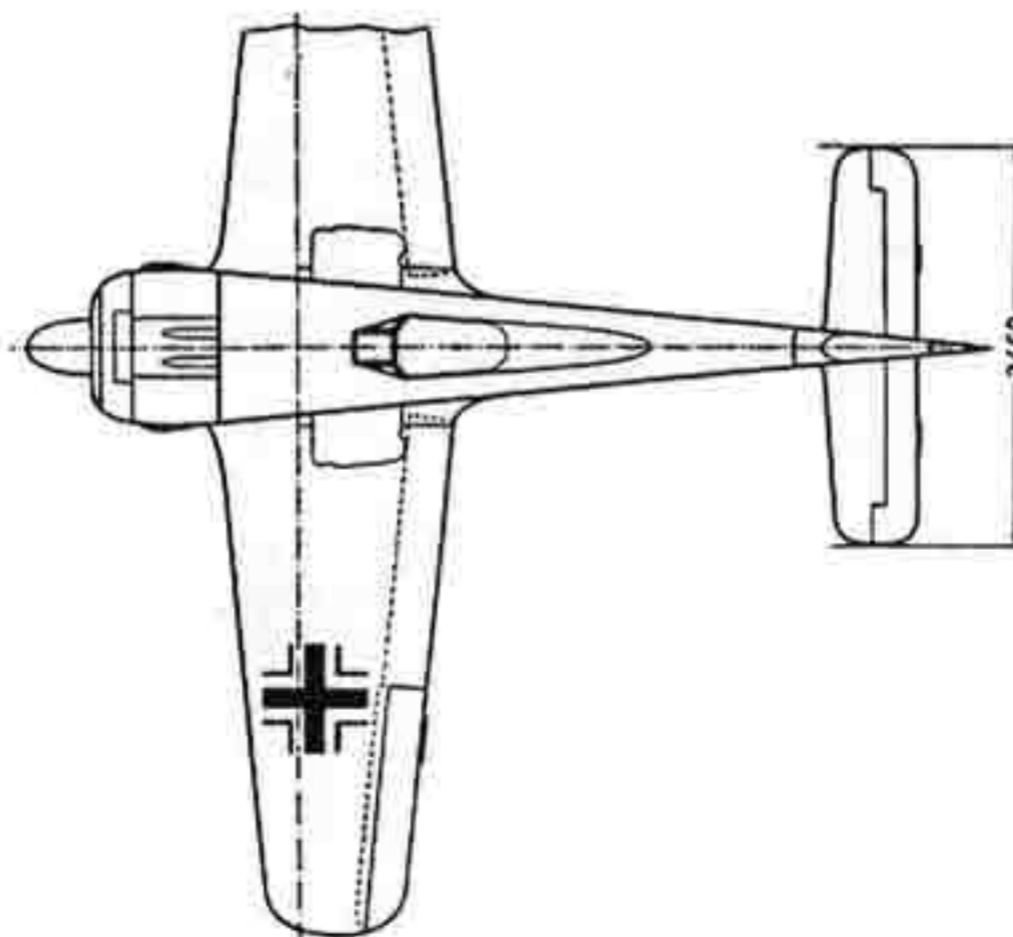
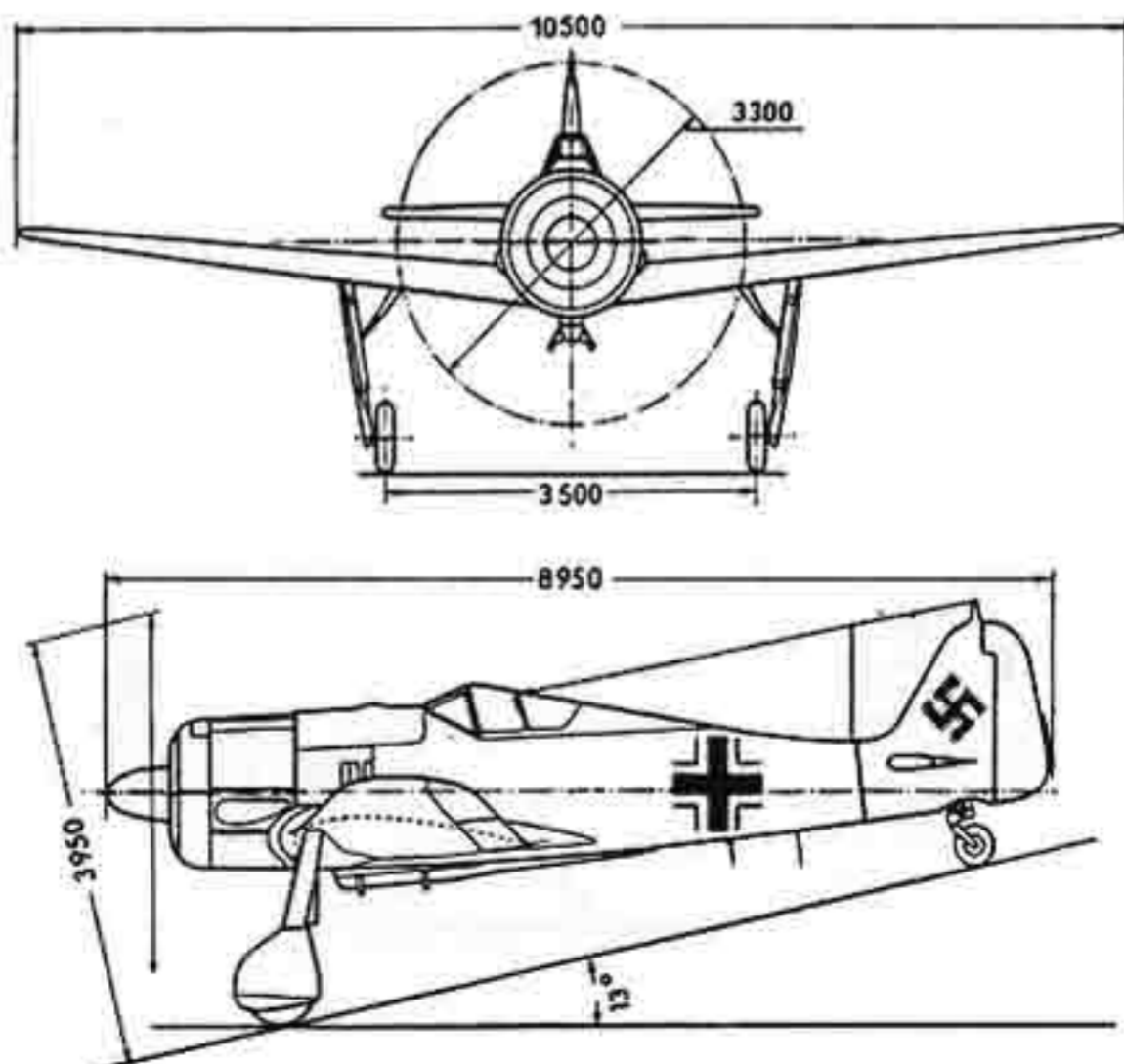

Fig. 2: Major dimensions

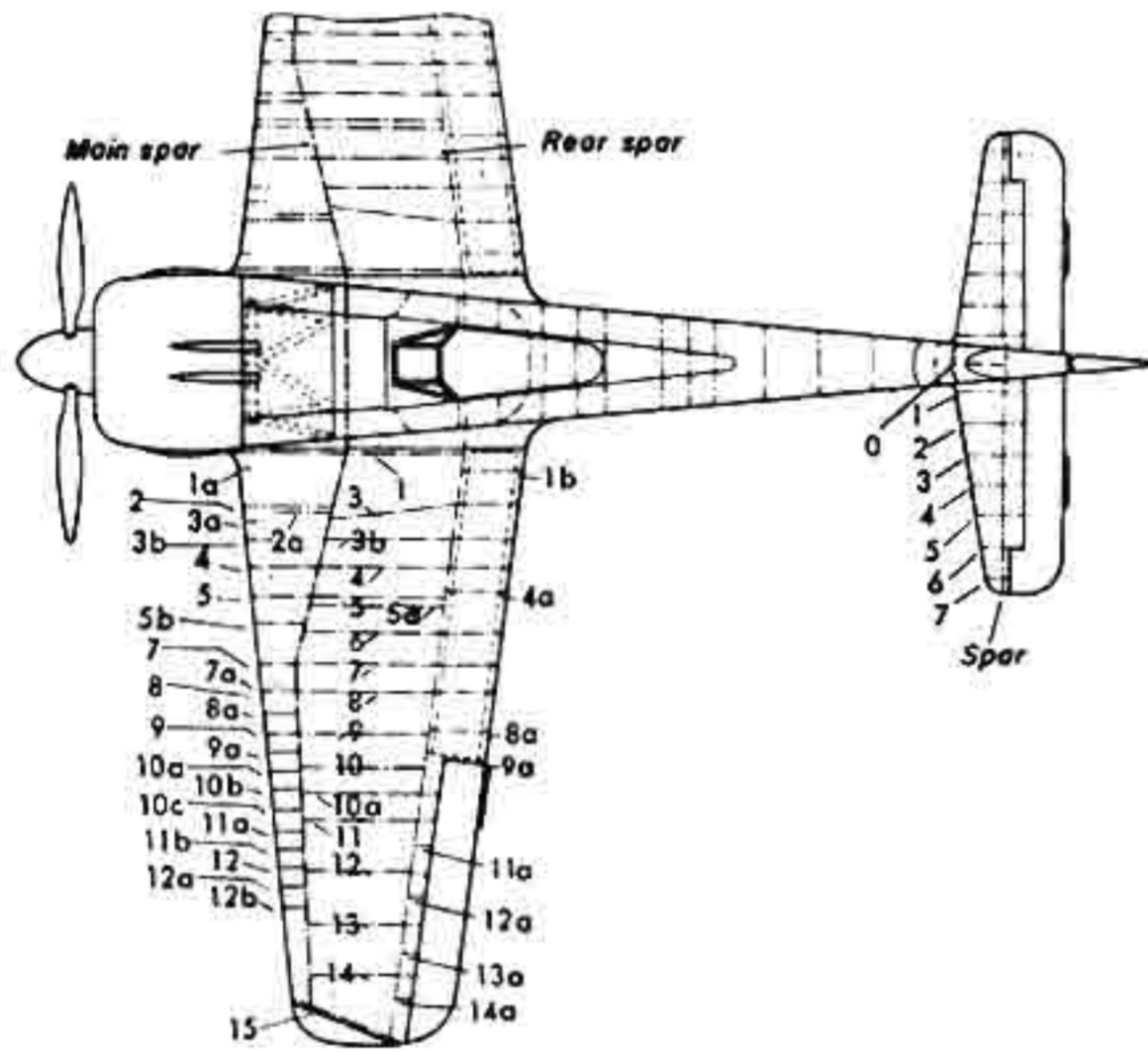
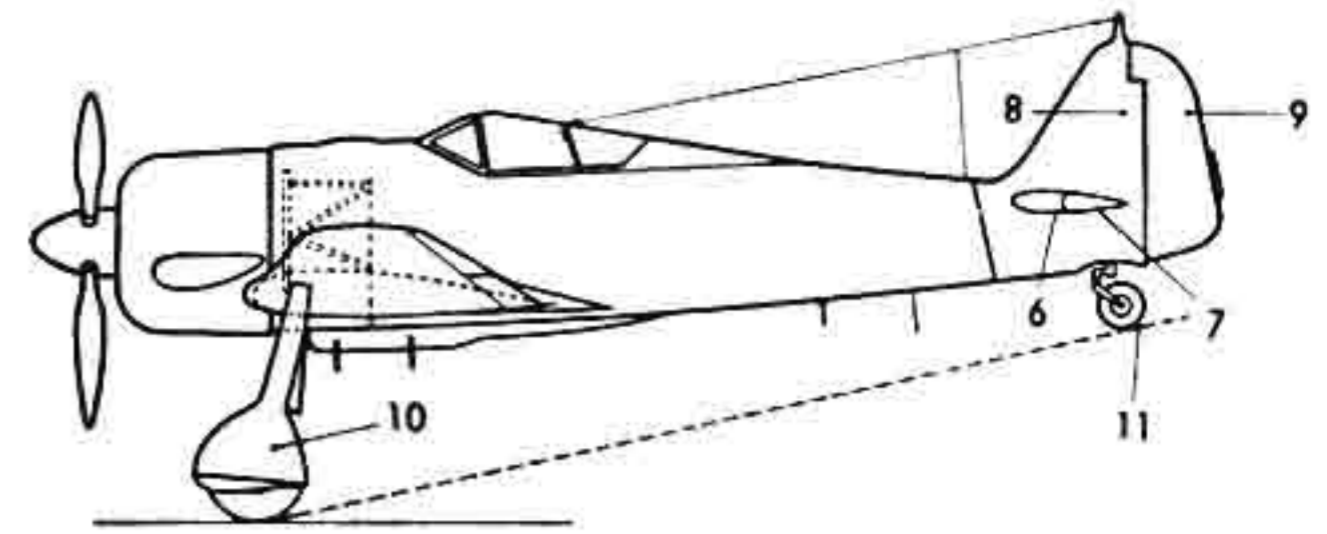
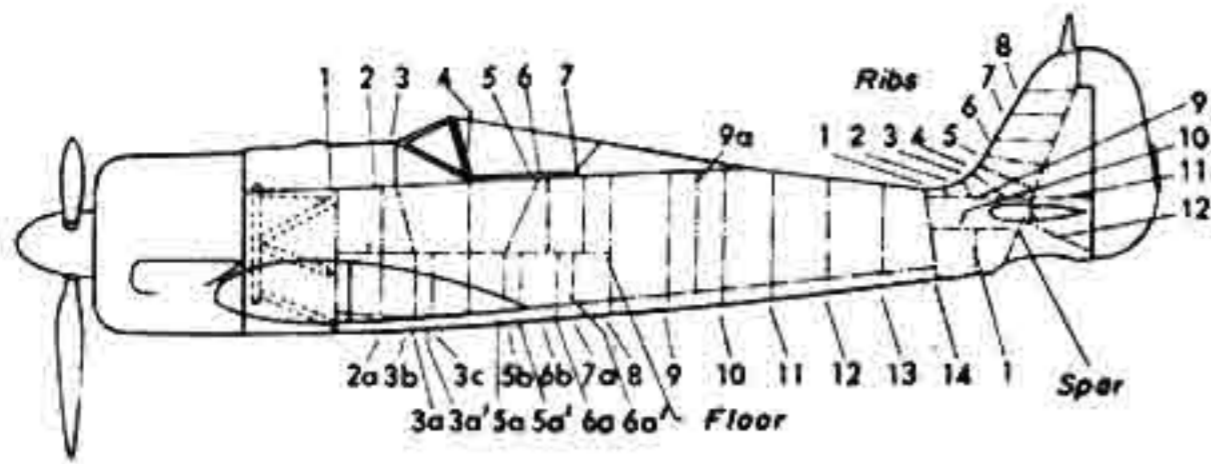

Fig. 3: Bulkhead and rib layout

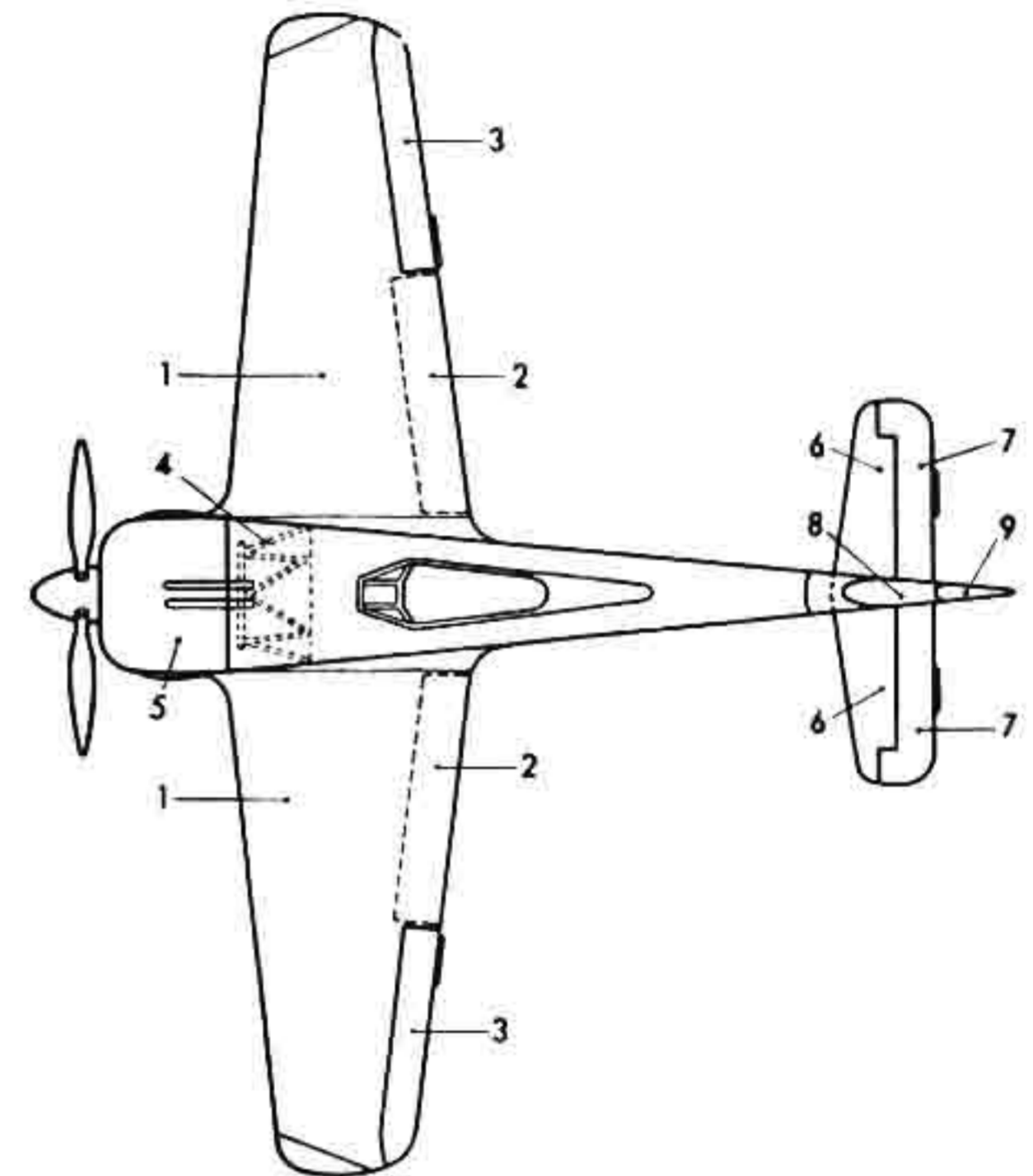

Fig. 4: Major components

### C. Aircraft assembly

#### 1. Major components

No	Designation	Attached to
1	Wings	Fuselage
2	Flaps	Wings
3	Ailerons	Wings
4	Engine bearer assembly	Bulkhead 1
5	Power unit	Engine bearer assembly
6	Horizontal stabilizer	Vertical stabilizer spar, spindle drive and anti-stress frame/guide
7	Elevator	Horizontal stabilizer
8	Tail unit with vertical stabilizer	Rear fuselage
9	Rudder	Vertical stabilizer
10	Undercarriage	Wing and u/c radius struts
11	Tailwheel unit	Tail unit



## 2. Covers and panels

No	Qty	Location	Purpose
1	1	Engine cowling, top	Engine servicing and inspection
2	2	Engine cowlings, side (rt & left)	Engine servicing and inspection
3	2	Engine cowlings, bottom (rt & left)	Engine servicing and inspection
4	1	Forward fuselage, rt	Forward fuel tank filler pipe cover
5	1	In fuselage armament panel	To open armament panel
6	1	Fuselage armament panel	Fuselage weapons installation and removal
7	2	Bulkhead 1, rt & left	Access to rudder pedals
8	2	Windscreen mounting unit, rt & left	Fuselage weapons installation and removal
9	1	Bulkhead 5, left	Control surfaces locking cord stowage
10	1	Forward fuselage, rt	Rear fuel tank filler pipe cover
11	1	Behind pilot's seat	Stowage bag cover flap
12	1	Rt fuselage between bulkheads 8 & 9	Oxygen and air tank filler pipe cover
13	1	Forward fuselage, left	Hand hold cover
14	1	Rt fuselage between bulkheads 11 & 12 (omitted)	First aid kit
15	2	Tail unit, rt & left	Installation, servicing and removal of horizontal stabilizer
16	2	Fuselage undersides, rt & left, beneath engine support frame	To cover the u/c lower wheel halves
17	2	Fuselage undersides, rt & left, forward of fuel tank cover	Installation and removal of wing-root weapons ammunition boxes
18	2	Forward fuselage, rt & left	Servicing and inspection of engine accessories
19	1	Forward fuselage, undersides	Fuel tanks installation and removal
20	1	Fuselage undersides, between bulkheads 8 & 9	Equipment trough cover
21	1	Fuselage undersides, between bulkheads 9 & 10	Bottom shell access cover
22	1	Forward fuselage, left	Entry step cover plate

No	Qty	Location	Purpose
23	1	Left fuselage between bulkheads 9 & 10	Installation and removal of equipment in equipment bay
24	1	Rt fuselage between bulkheads 10 & 11	External power connection
25	2	Rear fuselage lifting tube	Lifting tube covers
26	1	Vertical stabilizer, left	Servicing tailwheel unit and vertical stabilizer
27	2	Wing lower surfaces, rt & left	Extension of u/c fairings when ETC 501 fitted
28	2	Wing lower surfaces, rt & left	Undercarriage lower fairings
29	2	Wing roots, rt & left	Servicing, installation and removal of wing-root weapons
30	2	Wing lower surfaces, rt & left	Undercarriage upper fairing
31	2	Wing leading edge, rt & left, between nose ribs 7 & 7a	Centre wing leading edge cap
32	4	Wing lower surfaces, 2 per side (left & rt), between mid-	Installation, servicing and removal of flap drive motors
33	2	Wing lower surfaces, between mid-ribs 6 & 7	Installation and removal of u/c. Removal of wing gun cartridge casings
34	2	Wing lower surfaces, between mid-ribs 7 & 9	Installation, servicing and removal of wing guns
35	2	Wing lower surfaces, between mid-ribs 9 & 10	Servicing aileron controls
36	1	Rt fuselage between bulkheads 6 & 8	Radio bat access panel
37	1	Left fuselage between bulkheads 9 & 9a	Supplementary tank filler pipe cover (GM-1 or extra fuel tank)

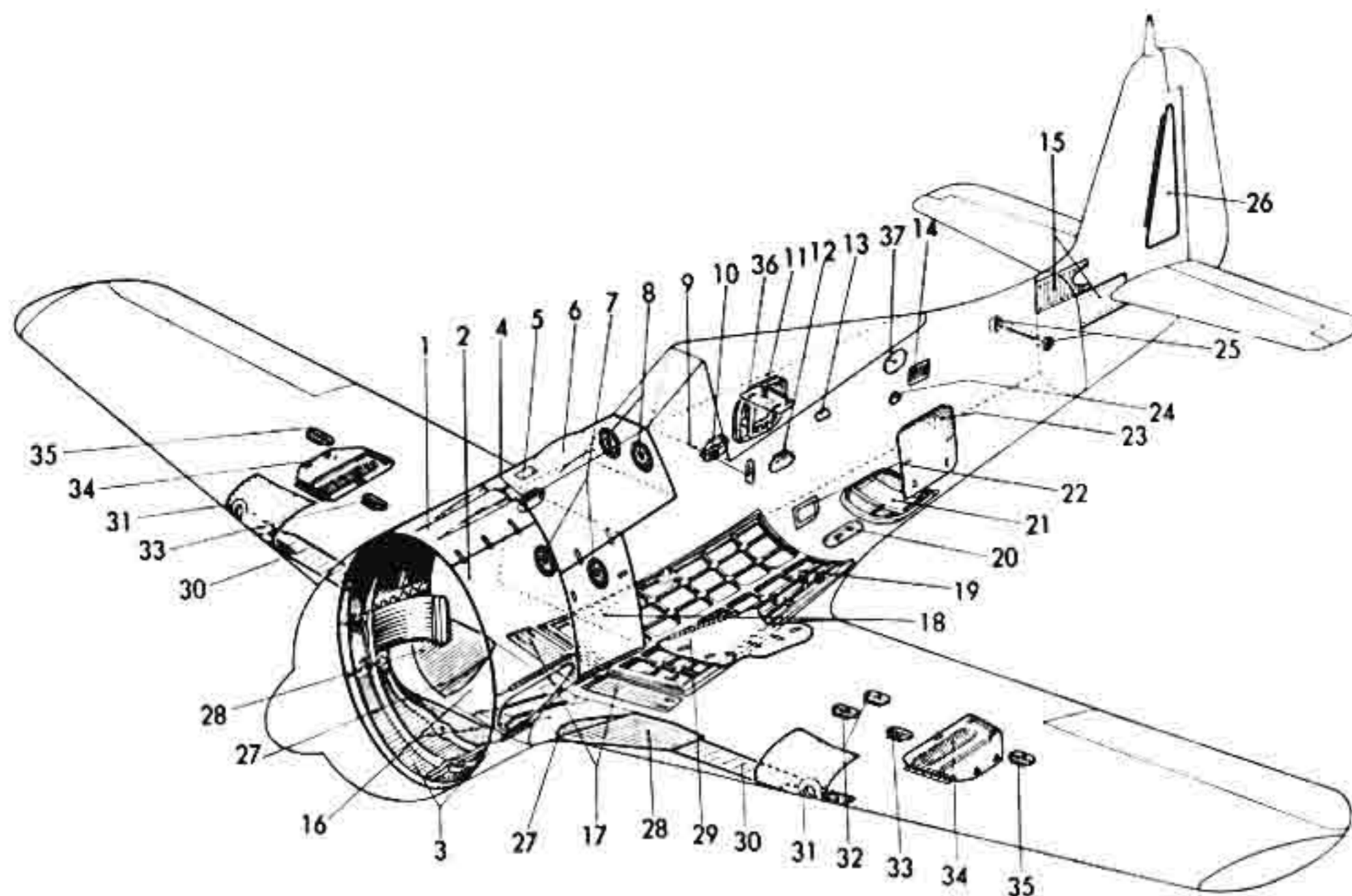

Fig. 5: Covers and panels

## II. General maintenance instructions

### A. General servicing instructions

This section includes all instructions required for general servicing duties.

#### 1. Threaded plugs

Before use, carefully clean threads with a clean rag. Due to the danger of explosion, ensure that Oxygen connections are kept free of oil and grease. To prevent seizure of bolt threads, smear them with Graphite paste before use. Cover screws with tape after removal.

#### 2. Loose rivets

In deciding whether or not a rivet is loose, consider the following:

1. Truly loose rivets rarely occur; they are almost always due to poor workmanship.
2. Rivets with black rims around their heads are often considered to be loose; from past experience, however, they are normally not. The formation of these rims is caused by a natural 'setting', due to stresses within deeply molded

metal panelling (see LgN 11 11 9 Sheet 1).

3. Rivets are loose:
  - a) when they can be moved by a probe or similar instrument;
  - b) when they are seated at an oblique angle (loose rivets which were pushed through the skin at an angle);
  - c) when a 0,1 mm thick probe can be inserted between the rivet head and the aircraft skin up to the rivet shaft (caused by joining a strong component to a weak skin).
4. Rivets are not loose:
  - a) when they only have black rims;
  - b) when a probe cannot be pushed under the rivet head.
5. Rivets, as described in paras 3a) through c), must be replaced during overhaul.

#### 3. Push-rod connections

During installation, the depth of push-rod connector screws can be checked using the connector inspection hole. When inserted, the inspection probe must contact the screw threads. Protect ball-bearing bushed push-rods against dirt (grease and wrap in oil paper).

## 4. Covers and panels

Covers and access panels must fit properly and close fully. The engine cover tension locks must, when locked, remain under tension. They are so designed that the lock cover can be closed with normal hand pressure.

## 5. Pipes and tubes

All open pipe ends are to be sealed with caps, or other similar means, to prevent the entry of dirt and foreign objects. Lines, where abrasion cannot be avoided, must be covered with leather. Before the engine is first run, and before installation of its fittings, the lines must be checked with air pressure. The lines to be checked must be tightly sealed and then tested using a line pressure about 50% greater than maximum system pressure. After the air is shut off, the lines must not lose more than 5% pressure in 5 minutes. Leakage inspection of fluid bearing lines is carried out while the engine is running on a test stand. Upon their reaching system operating pressure, check the lines for leaks.

Pipes and tubes are coded with coloured rings, or glued-on coloured bands, in accordance with DIN 5, to identify the circuits to which they belong.

## 6. Cleaning the painted surfaces

Check the condition of the external painted surfaces. Carefully remove oil and engine exhaust deposits with "Ikarol 237" detergent. Then, thoroughly rinse off these areas with water and dry them. Cleaning the external paint with gas, Benzol, turpentine or alcohol mixtures, even if they are in diluted solution or in paint thinner, is forbidden. These solvents will loosen the paint.

To recognize and then remove corrosion damage, the aircraft must be cleaned from time to time, and especially during overhaul.

After dusting off the outside surfaces with a soft-haired brush, wash off the firmly fixed dirt with clean, luke-warm water. Or, wash them with a weak, non-alkali soap and rinse with water. Afterwards, wipe off the surfaces with sponges and rags. Clean the main and tail wheels frequently with water and brushes to remove any dirt. The "Paint Chart" gives information as to the care of paint applied to steel and aluminum parts.

## 7. Cleaning plexiglass

To remove dust and dirt from Plexiglass surfaces, clean them with water at 40°C to 50°C, applied with a natural or viscous sponge, and then buff dry with a polishing cloth. To cut through the heavier dirt,

add liquid soap or soda. "Glasurit-Aircraft cleaner" with water, in a 1:20 solution, can also be used. When buffing a wet glass panel, put some "Plexipol II" on the buffing cloth. The use of abrasive or oily polishing -, scouring -, or varnish compounds, or of gas or Benzol, is forbidden (the glass panels will become opaque). Remove varnish, grease, oil or paint with "Sangajol".

During buffing, remove any remaining grease and oil with "Plexipol II". Rub small scratches and opaque glass panels with "Plexipol I" until the problem is eliminated. Then finish off the job with "Plexipol II". Small scratches can also be removed mechanically with a twill fabric buffing wheel and polishing compound.

Before painting the aircraft, cover all glassed areas with oil-paper. Further servicing information is included in Luftwaffe pamphlet No. 1/96 of 3.8. 1938--"Flight Safety Inspections and Required Equipment". The same pamphlet includes maintenance instructions for the bullet-resistant glass panel and the windscreen side panels.

## 8. Overhaul

TAGL No. 257/42 provides for an airframe inspection cycle of 200/5. This means that after 200 engine hours a partial overhaul, and after five partial overhauls a complete overhaul takes place. An inspection cycle of 100/2 has been set for the BMW engine. A complete overhaul is to be carried out only at a Maintenance Depot. If, over the space of a year, no partial overhaul is carried out on the engine or airframe, a special inspection is to be carried out to confirm the serviceable condition of that airframe or engine, and so permit it to retain its status. After 200 take-offs carry out an undercarriage actuation test.

## B. General instructions for aircraft assembly and disassembly

### 1. Basic instructions

Avoid the use of unsuitable tools. Use special tools only for their prescribed tasks. Carefully plan each job before beginning it. Ensure that the electrical circuits are disconnected so that inadvertent tripping of switches won't cause an accident. Fire-fighting equipment should be positioned near the work area. DO NOT approach an aircraft with an open flame, or smoke in the work area. Only use electrical equipment that is fitted with a spark suppressor. During drilling, ensure that either no red-hot chips are generated or that adequate cooling of the drill bit is maintained.

## 2. Aircraft walk zones

For working in or on the aircraft, wear only soft soled shoes. For stepping on the outer wing panels, first lay the mats provided.

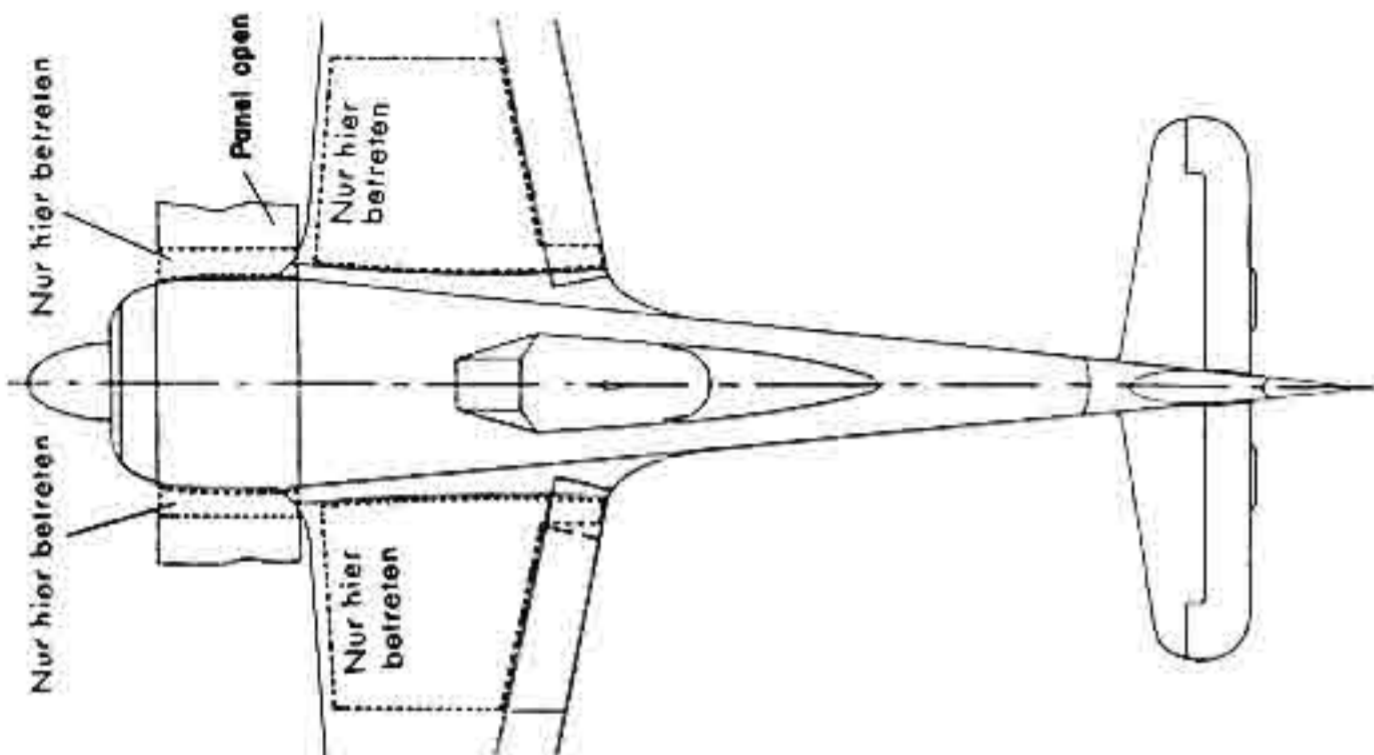

Fig. 6: Aircraft walk zones

## 3. Placement of parts and tools

To avoid damage to removed parts, remove them completely, on padded sheeting or matting, out of the work area. Tools required for servicing and overhaul must be carefully placed on padded sheeting on the aircraft. After job completion, a foreign objects check must be carried out before the first flight.

## 4. Marking of parts

For major disassembly tasks it is advisable to immediately mark each removed part, and so ensure a smooth work flow during reassembly. Special care must be taken to correctly mark the control stick control rod attachment points and the related push-rods.

## 5. Control wire and cable tensions

Cable tension is to be measured with an FW-tension meter. New cables must be prestretched after splicing.

## C. Lifting and trestling

### 1. Lifting

The short lifting cable is placed around the rod in the rear fuselage, the long one around the lifting lugs on the engine mounting ring; both cables are

attached to the same lifting hook. After lifting, the aircraft hangs in a well-balanced position; it is steered, during movement, by a cable attached to the tailwheel.

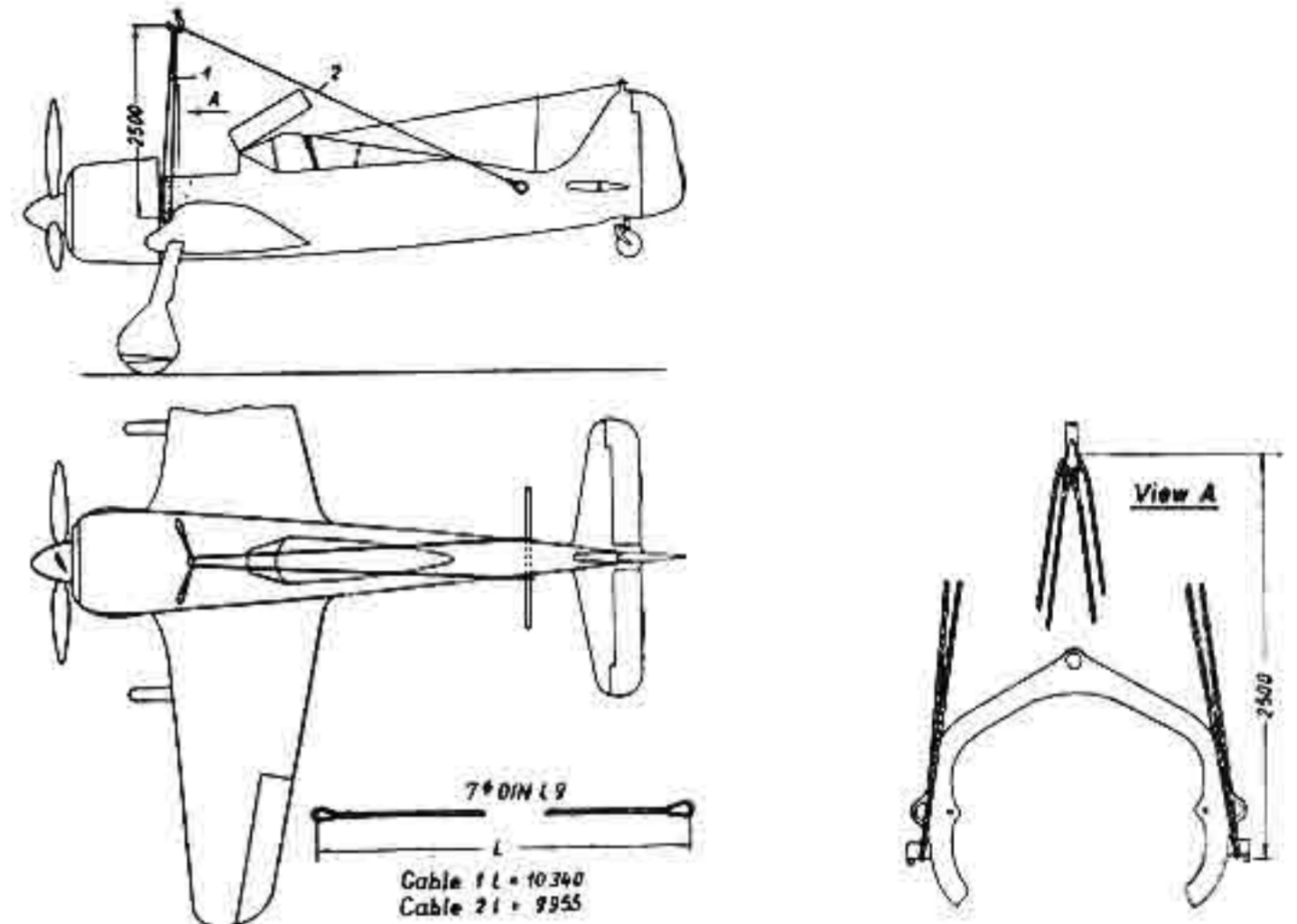

Fig. 7: Lifting the aircraft

### 2. Trestling



Fig. 8\*: Trestling the aircraft

The aircraft is to be trestled only on the trestle points provided on the undersides of the right and left wing panels behind the undercarriage pivot points. The rear fuselage is placed in a sling, lifted, and after placement of the lifting rod onto the rear fuselage trestle (W8-190.00-102), is released.

#### Important!

The rear fuselage trestle must have a 70 kg (157 lb) weight added to it when the complete aircraft, including engine and tail unit, is trestled; when the tail unit is removed, this weight must be increased to 175 kg (386 lb).

If a rear fuselage trestle (W8-190.00-102) is not

available, a makeshift arrangement is possible. In this, the rear fuselage is supported by a sufficiently long lifting bar, between two suitable trestles and is weighed down as indicated above.

The rear fuselage trestle, W8-190.00-105, is used for trestling only the aircraft tail. The trestle is placed in the designated position beneath the rear fuselage, and wheel chocks are placed both in front of and behind the mainwheels.

## D. Towing

Towing can be carried out with either a towing crew or towing vehicle. When towing with a vehicle, avoid pulling it rearwards (Tail strut fracture).



Fig. 9: Towing with a towing vehicle



Fig. 10\*: Towing forward with a towing crew



Fig. 11\*: Towing rearward with a towing crew

The towing cables are inserted through loops on the upper shock struts. A forked bar attached to the tailwheel is used to steer the aircraft. Avoid backing up the aircraft during towing.

When towing an aircraft with a towing crew, ensure that the aircraft control surfaces are not pushed against.

To tow the aircraft rearwards using a towing crew, slide a pipe (or tube), sufficiently long to allow room for two men pushing per side, through the lifting tube. One man handles the forked tailwheel bar.

Before towing, first ensure that the tailwheel locking unit is disengaged.

## E. Anchoring and covering

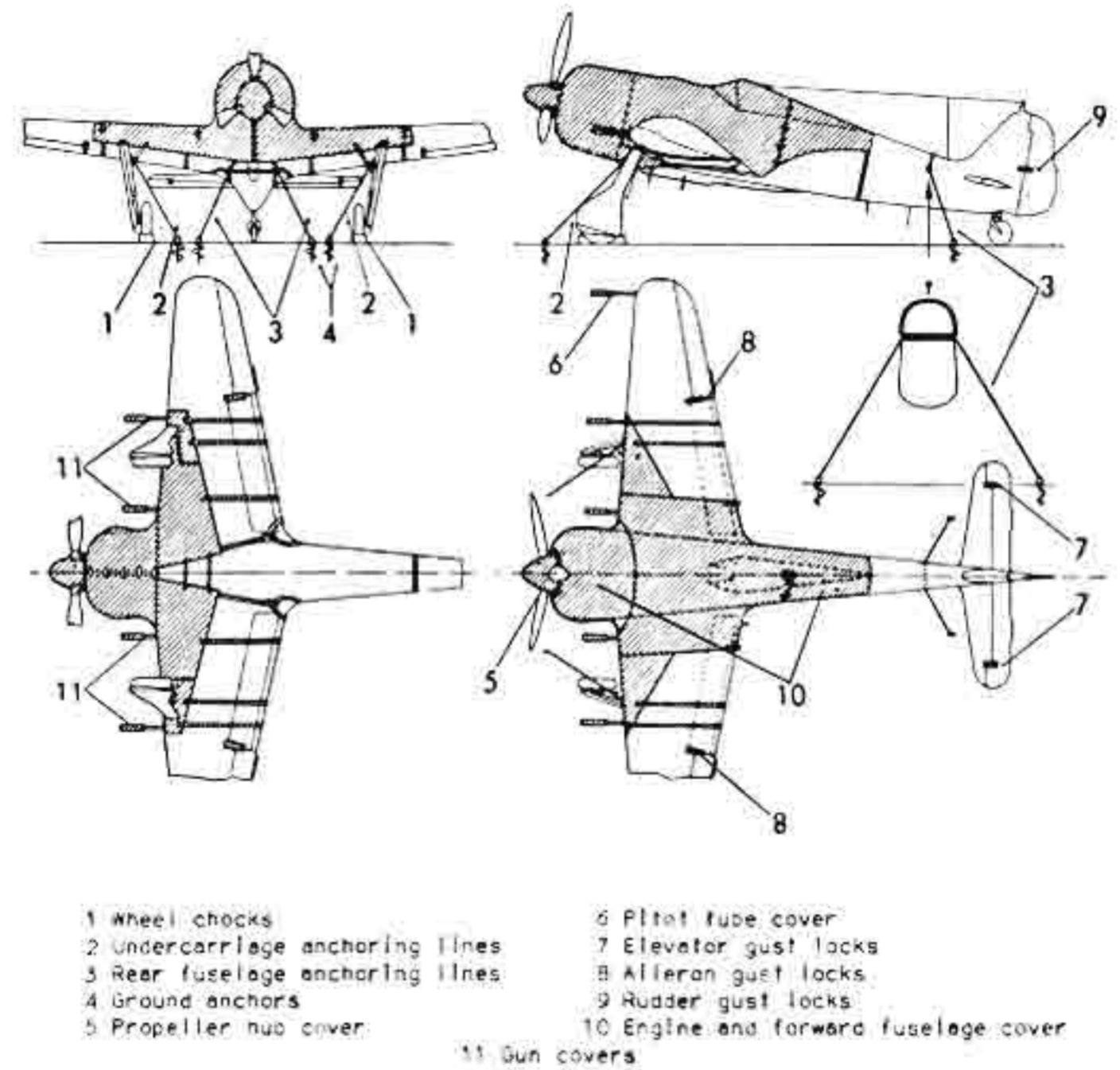

Fig. 12: Aircraft anchored and covered

Aircraft left standing in the open must be anchored, to four ground anchors, and covered. Place wheel chocks in front of and behind each mainwheel. The control surfaces locking cord is hooked onto the left rudder pedal and connected to the control column. The various control surfaces are held in position by gust locks. For temporary parking in calm weather conditions, use of the control surfaces locking cord is sufficient.

At the front, the aircraft is anchored by the towing loops; at the rear; by the rear fuselage lifting tube.

The aircraft rear anchoring line is inserted in one

side of the lifting tube, is pulled slightly more than half way through, wrapped over the fuselage, reinserted in the lifting tube, and pulled through to the other side.

The airscrew must be so positioned that one propeller blade points vertically upwards.

The anchoring lines are pulled tight. In case of rain, the lines must be loosened as they will contract when wettened. On the other hand, in stormy weather (high winds), the lines must be tightened.

The powerplant and forward fuselage are covered by a single sheet. Pullover covers are also provided for the airscrew spinner, the pitot tube and the cannon barrels.



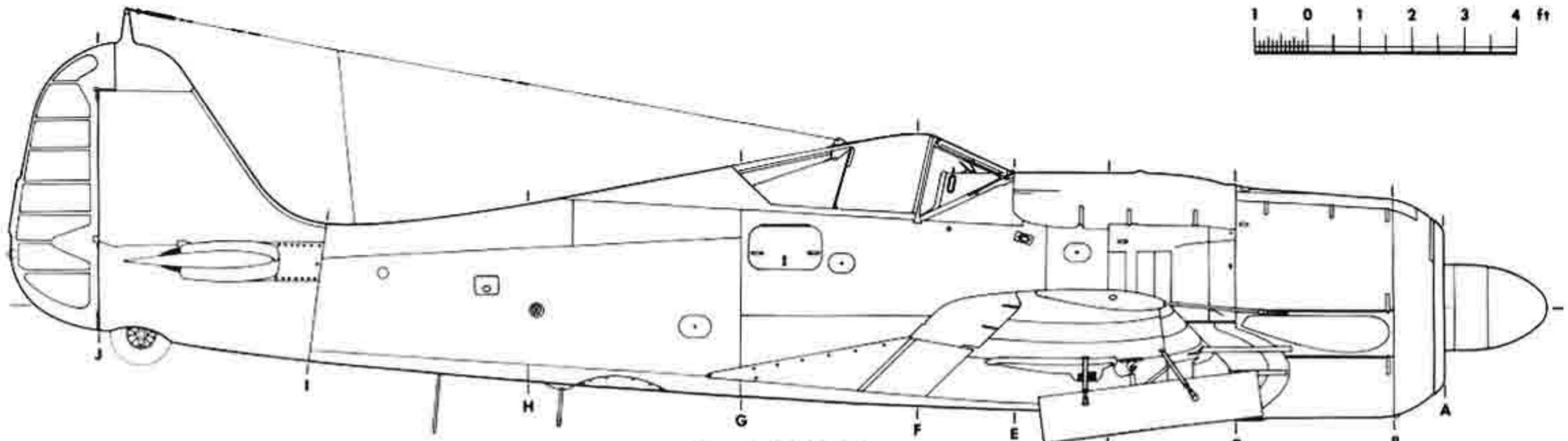

**Fw 190A-8**

(With underwing 21-cm BR weapons system)

**Recognizing the Fw 190A-8:**

- 1 Bulged fuselage armament panel housing two MG 131 13mm machine guns (also on A-7)
- 2 FuG 16ZY Morane antenna on underside of left inner wing panel
- 3 Pitot tube at right wing tip

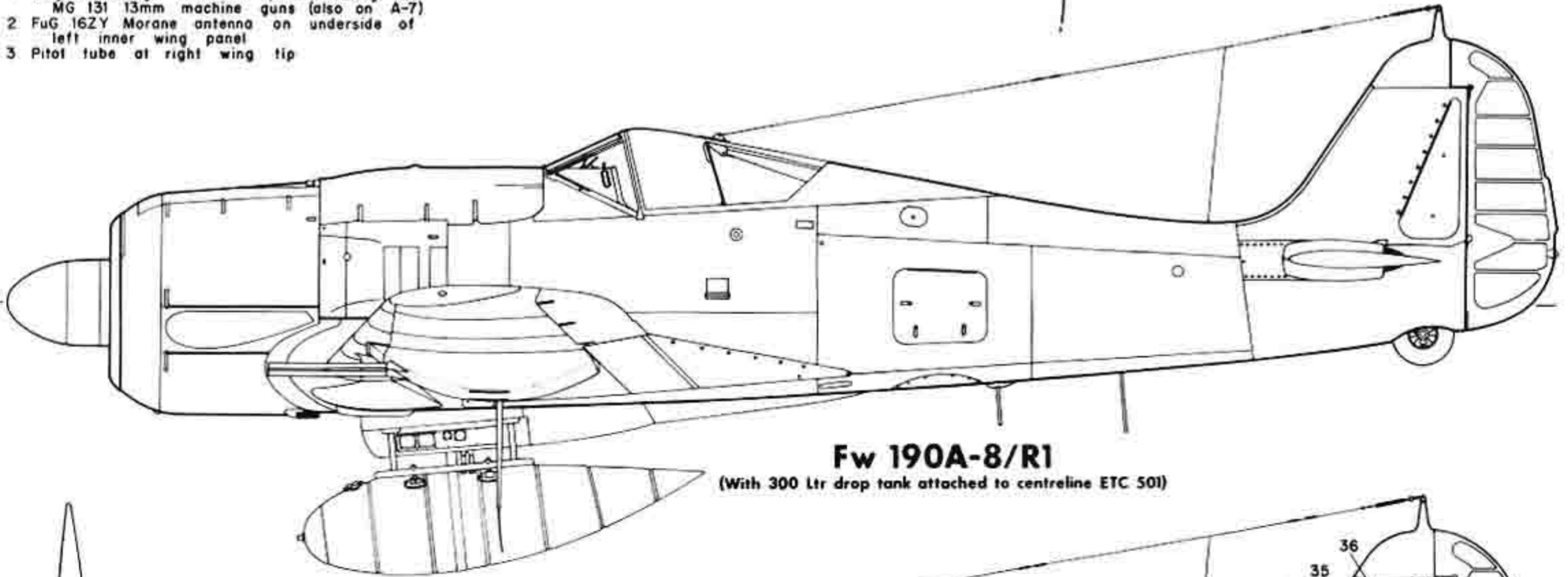

**Fw 190A-8/R1**

(With 300 Ltr drop tank attached to centreline ETC 501)

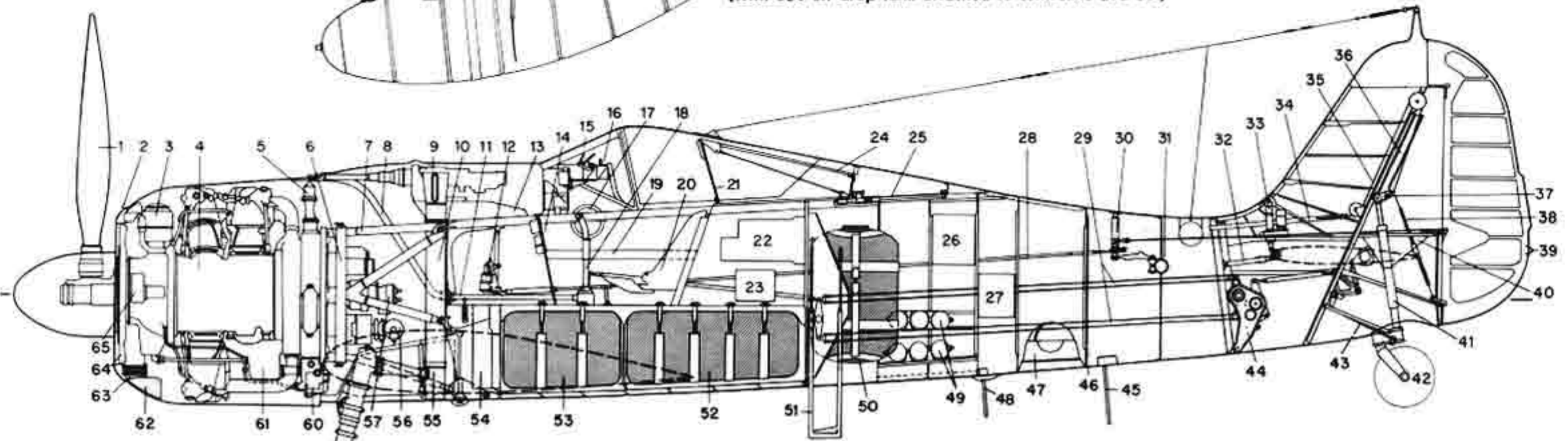

- 1 VDM 3-bladed, adjustable pitch, constant speed, airscrew (10'10" dia)
- 2 Oil cooler nose ring (5mm armour)
- 3 Bosch twin magneto
- 4 BMW 801D-2 14-cylinder radial engine (1700 hp)
- 5 Synchronization gear for wing-root weapons
- 6 Engine mounting ring with integral control unit oil tank
- 7 Engine bearer assembly
- 8 Cockpit fresh air pipe
- 9 MG 131 13mm machine gun
- 10 Fuselage weapon ammunition box (400 rounds per gun)
- 11 Aileron control actuation rod

- 12 EC-rudder pedal with integral brake pump
- 13 SiL 131/5 B fixed mount and carrier bracket
- 14 Instrument panels
- 15 Bullet resistant windscreen (50mm thick at 25°)
- 16 Revi 16B reflector gunsight
- 17 Canopy actuation gear
- 18 KG 13B control stick
- 19 Instrument console
- 20 Pilot's seat with armoured rear panel
- 21 Head armour (14mm thick)
- 22 FuG 16ZY transmitter-receiver unit
- 23 FuG 16ZY power transformer
- 24 Head armour support strut
- 25 Canopy centre guide tube (contains explosive charge for canopy jettison)
- 26 FuG 25a transmitter-receiver unit
- 27 FuG 16ZY homer bearing converter
- 28 DUZ rudder actuation rods
- 29 Elevator control cables
- 30 Rudder deflection reduction gear
- 31 Rear fuselage lifting tube
- 32 Triangular stress frame
- 33 Stabilizer trim drive motor
- 34 Tail wheel retraction cable guide tube
- 35 Retraction cable
- 36 Tail wheel shock strut guide
- 37 Tail wheel extension lock
- 38 Tail wheel extension spring

- 39 Tail light
- 40 Fabric cuff
- 41 Tail wheel shock strut
- 42 Tail wheel (350 x 135 tire)
- 43 Tail wheel lock actuation rod
- 44 Elevator differential bellcrank
- 45 FuG 25a antenna
- 46 Bulkhead 12 containing fabric panel
- 47 Master compass sensing unit
- 48 FuG 16ZY fixed loop homing antenna
- 49 Oxygen bottles (9)
- 50 Tank for GM-1 (18.7 gal) or fuel (25.3 gal)
- 51 Retractable step
- 52 Fuselage rear fuel tank (64.5 gal)
- 53 Fuselage forward fuel tank (51 gal)
- 54 Wing root gun ammunition box (250 rounds)
- 55 Link belt segment/cartridge casing chute for fuselage weapons
- 56 Fuel de-aerator
- 57 Engine starter unit
- 58 Main undercarriage shock strut
- 59 Main wheel (700 x 175 tire)
- 60 Engine oil pump
- 61 Oil sump
- 62 Circular oil tank (12.1 gal)
- 63 Circular oil cooler
- 64 Engine cooling fan
- 65 Propeller pitch adjustment mechanism

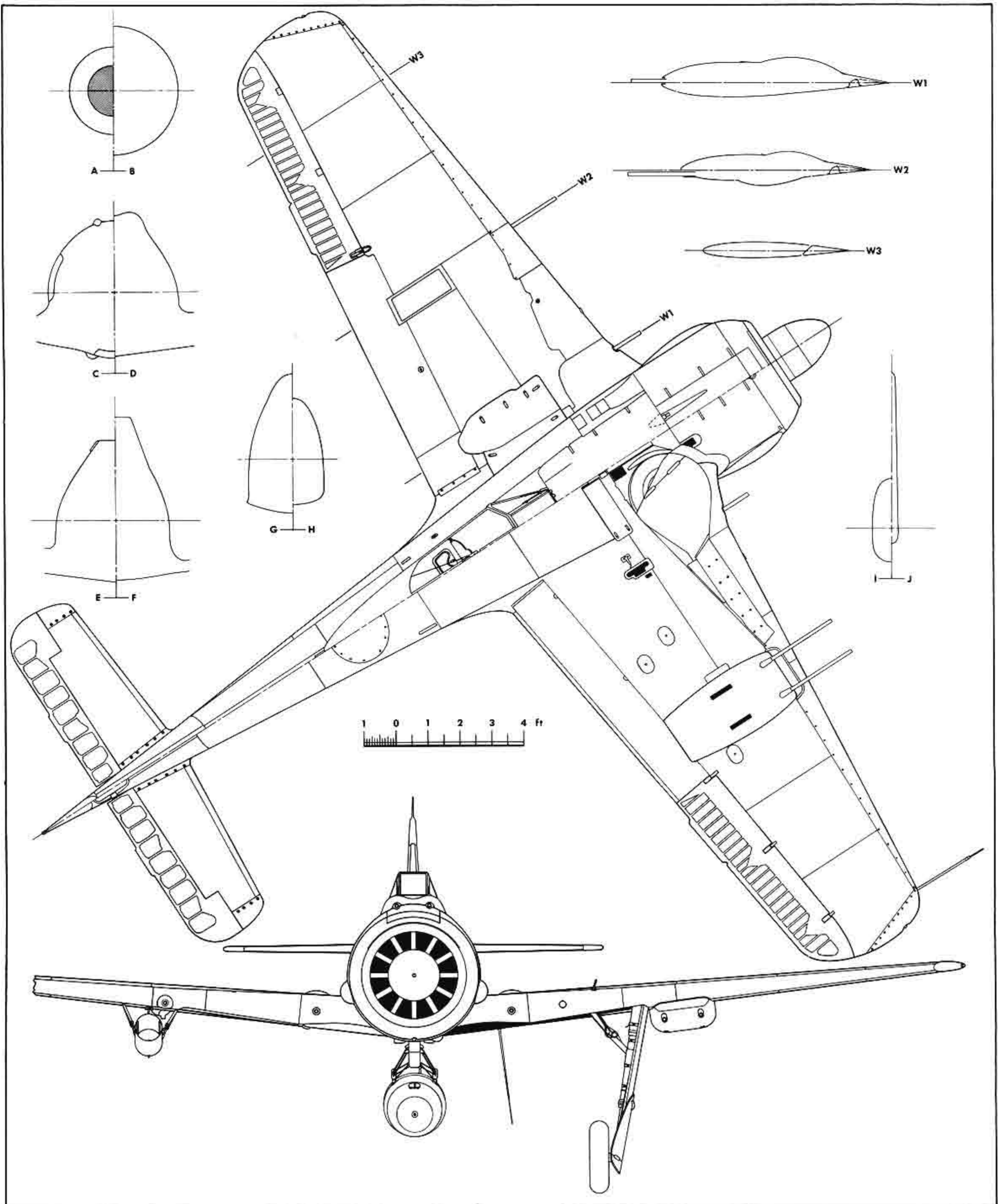



D. (Luft) T. 2190 A-8

For Official Use Only!

# **Fw 190 A-8**

Aircraft Handbook

**Part 1**

**Fuselage**

**(Effective July 1944)**

**Issued September 1944**

## Description

The Dural fuselage, of monocoque construction, is of circular cross-section at the forward end for matching to the radial engine; and of oval cross-section at the rear end for matching to the tail unit.

The fuselage is divided into a forward section (1,1) and a rear section (1,2).

The fuselage forward section comprises the windscreen framework (1,3), the engine bearer assembly (1,4), and the fuel tank cover panel (1,5).

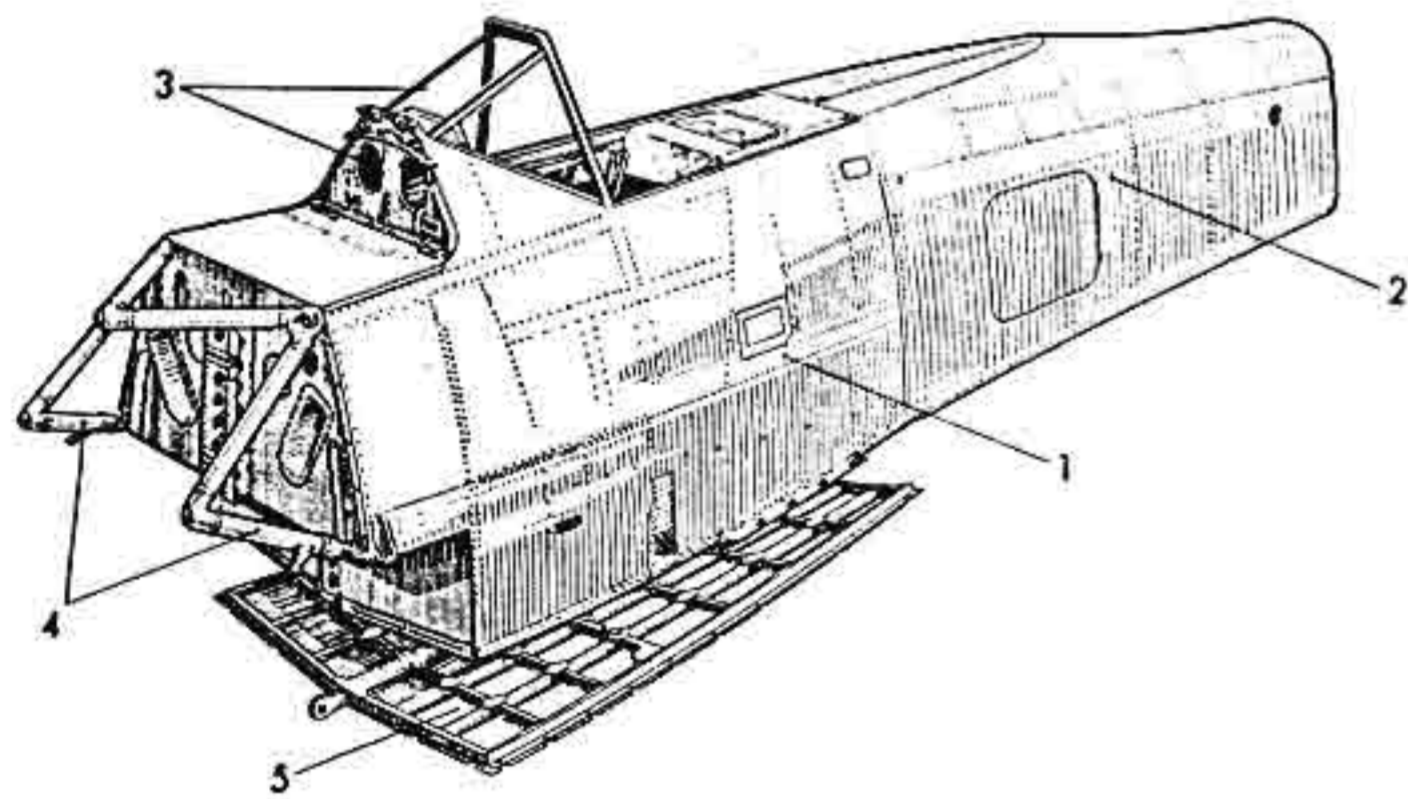

1 Forward section      3 Windscreen framework  
2 Rear section      4 Engine bearer assembly  
5 Fuel tank cover panel

Fig. 1\*: Fuselage

### A. Forward fuselage

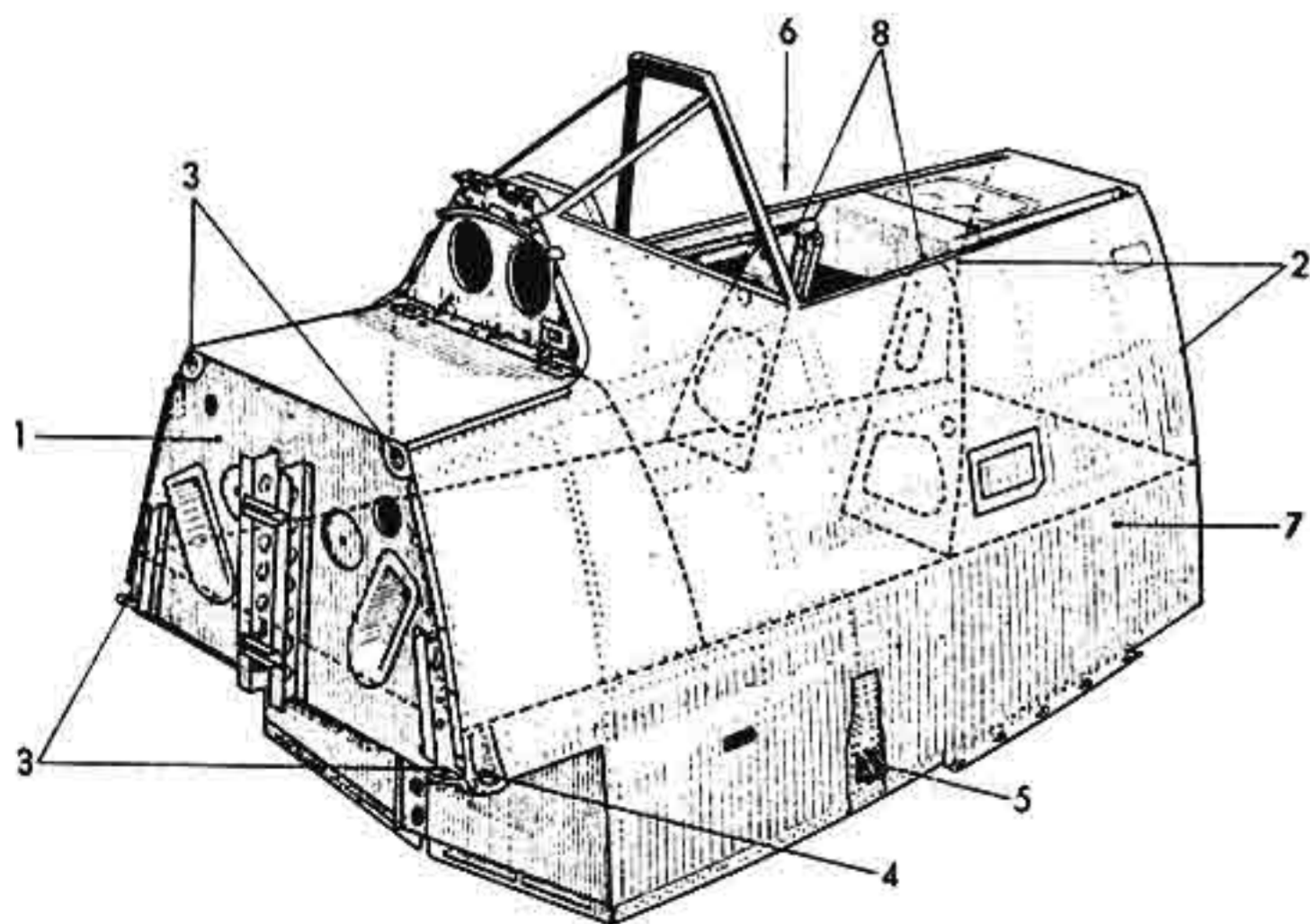

1 Firewall      5 Rear spar attachment point  
2 Bulkhead B      6 Cockpit  
3 Engine bearer assembly attachment points      7 Fuel tank compartment  
4 Wing forward spar attachment point      8 Seat mounting frame

Fig. 2: Forward fuselage

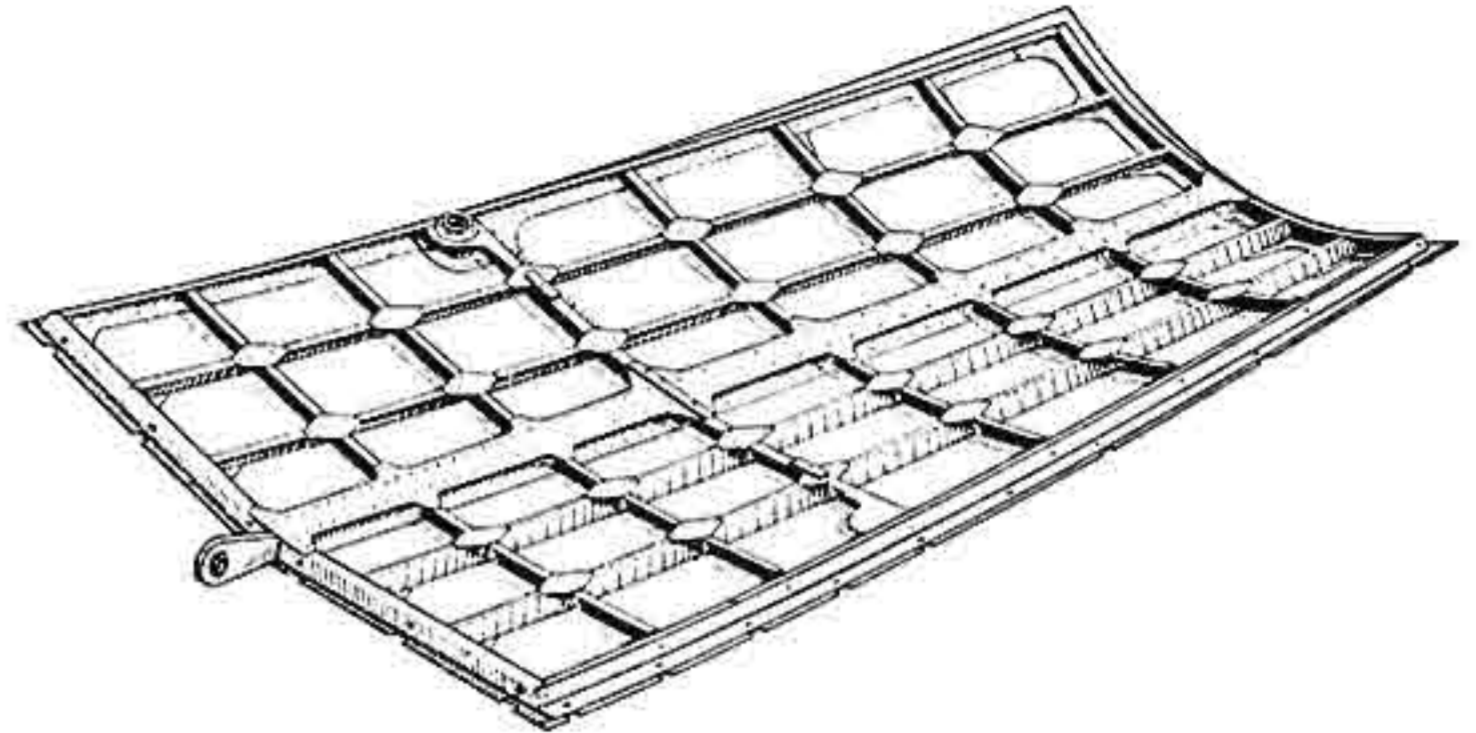
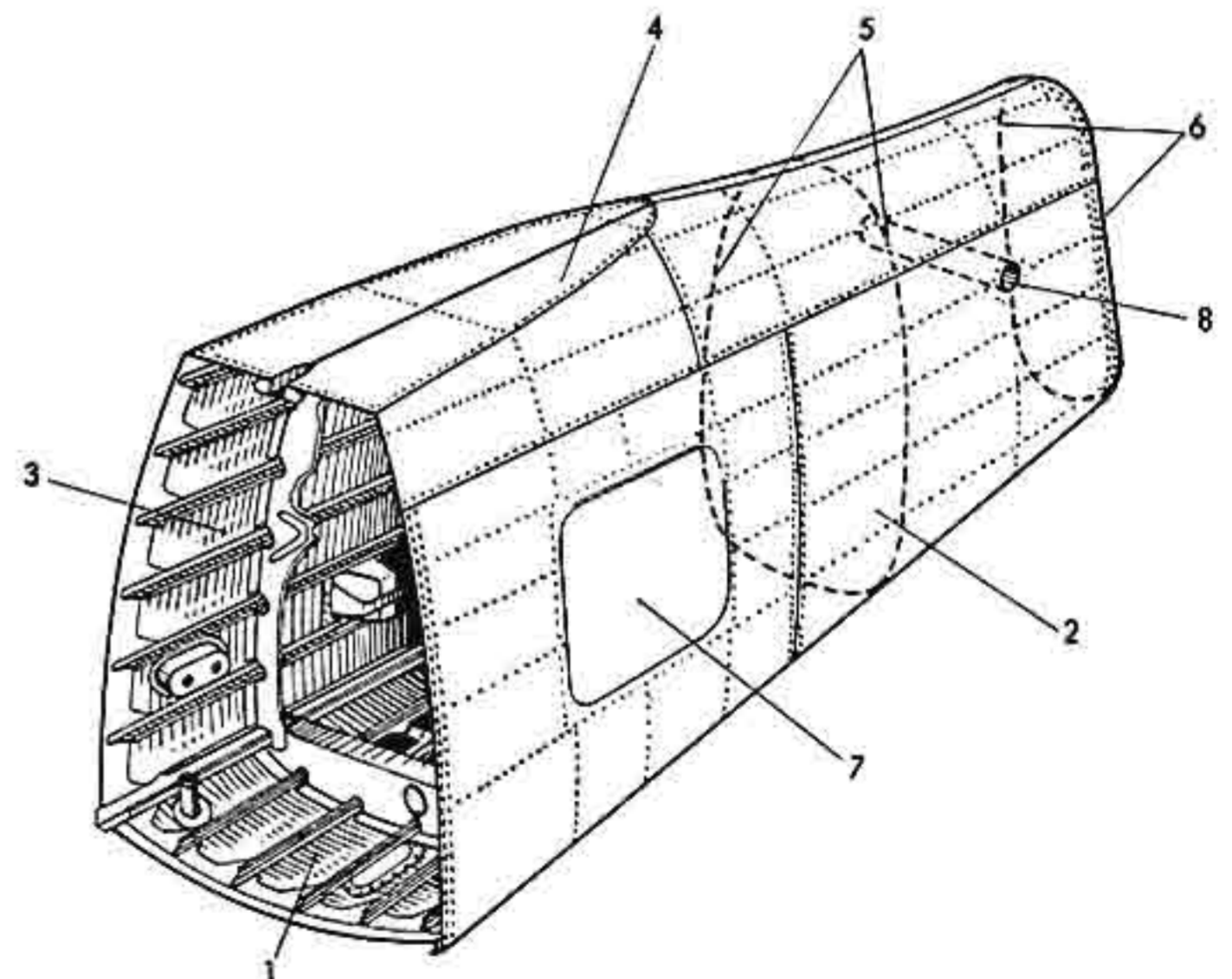

Fig. 3: Fuel tank cover panel

The forward fuselage (Fig. 2) extends from the firewall (2,1) to Bulkhead B (2,2). On the firewall are the attachment points for both the engine bearer assembly (2,3) and the wing main spar (2,4). The wing rear spar attachment points are on both sides of Bulkhead 4.

It contains the cockpit (2,6) and the fuel tank compartment (2,7). The latter is enclosed by the fuel tank cover panel (Fig. 3).

The seat mounting frame (2,8) closes off the rear of the cockpit. It comprises two frame segments, attached to the fuselage sides, and includes integral seat adjustment channels.



1 Lower shell      5 Fabric panel  
2 Left shell      6 Tail unit attachment frame  
3 Right shell      7 Equipment access panel  
4 Upper decking      8 Rear fuselage lifting tube

Fig. 4\*: Rear fuselage

## B. Rear fuselage

The rear fuselage (Fig. 4) consists of a lower shell (4,1), left and right shells (4,2 and 4,3), an upper decking (4,4), as well as a fabric panel (4,5), and a rear frame containing mounting points for the tail unit (4,6).

The shells are composed of frame segments, longerons and outer skin panels. The lower frame shell segments are so constructed as to also serve as platforms for the Oxygen bottles, transformers, etc.; while the side shell frame segments carry the W/T platform supports. The equipment access panel (4,7) is located in the left shell, its hinge being screwed onto the shell. The panel, internally strengthened, is held open by a folded strut, and is held closed by four quick-release fasteners which slide into the side shell. A tube (4,8), designed to accommodate a lifting bar, forms part of Bulkhead 13. The upper decking (4,4) is composed of two skin panels, riveted to a U-shaped channel which acts as a guide for the cockpit canopy centre roller.

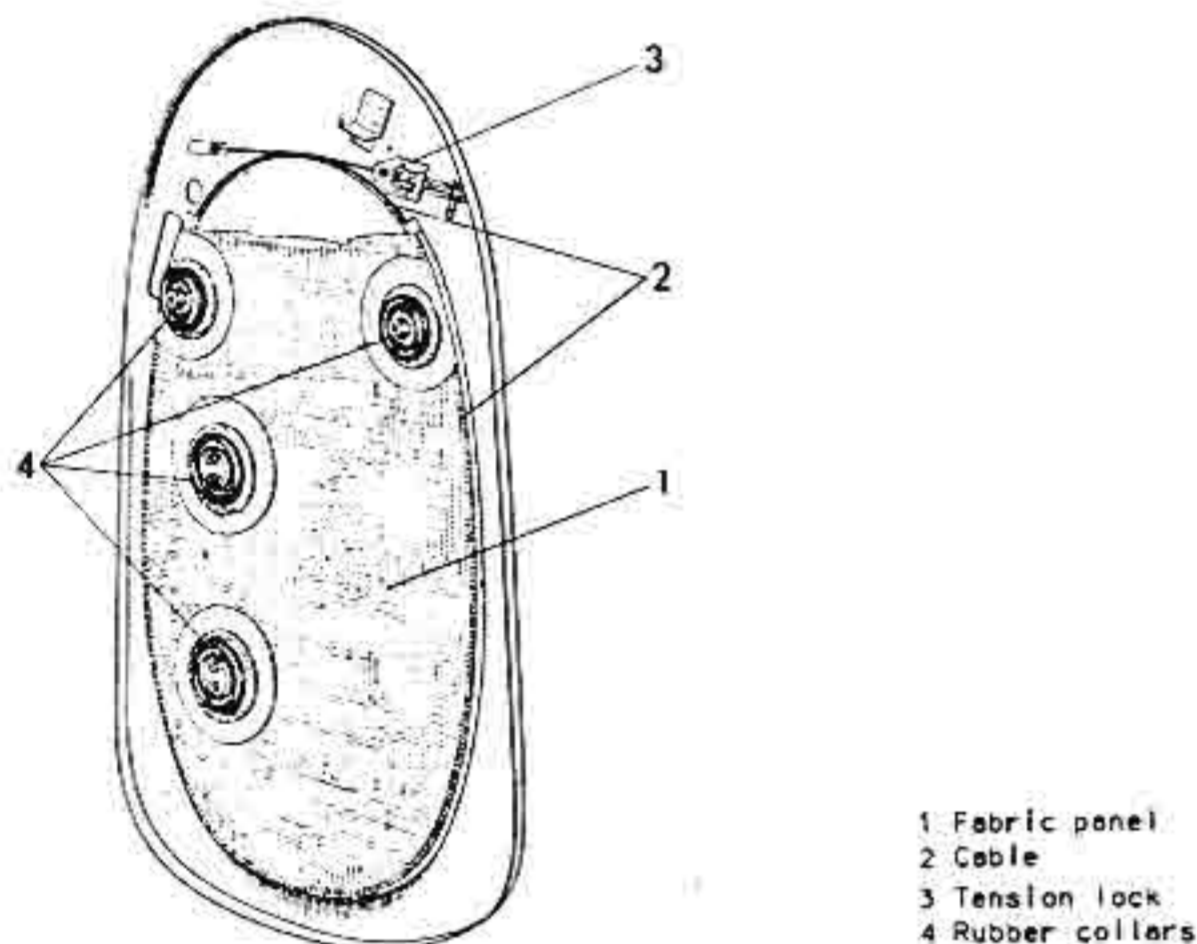

Fig. 5: Sealed panel

A sealed panel (Fig. 5) prevents engine exhaust fumes from being sucked forward into the cockpit. The cellulose acetate line sheet (5,1) is held in place by a cable (5,2) which is stretched over the rolled inner edge of the frame (Bulkhead 12), and is secured by a tension lock (5,3). Rubber collars (5,4), enclosing alloy bushings, permit the passage of control cables through the panel.

## C. Windscreen unit

The windscreen unit (Fig. 6) is panelled with three sheets of bullet resistant glass (6,1). The mounting

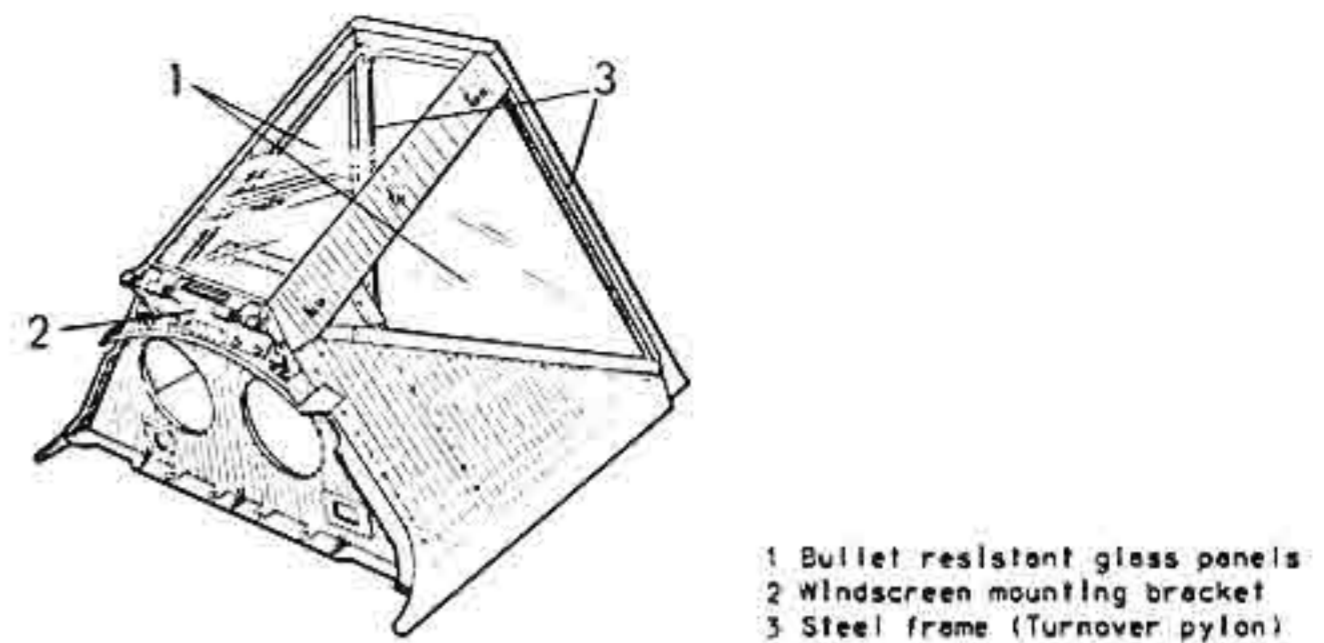

Fig. 6\*: Windscreen unit

bracket (6,2) serves also as weapon, gunsight and instrument panel carrier unit, as well as fuselage armament cover hinge point.

A self-supporting welded steel frame (6,3) forms the rear support for the glass panels.

## D. Engine bearer assembly

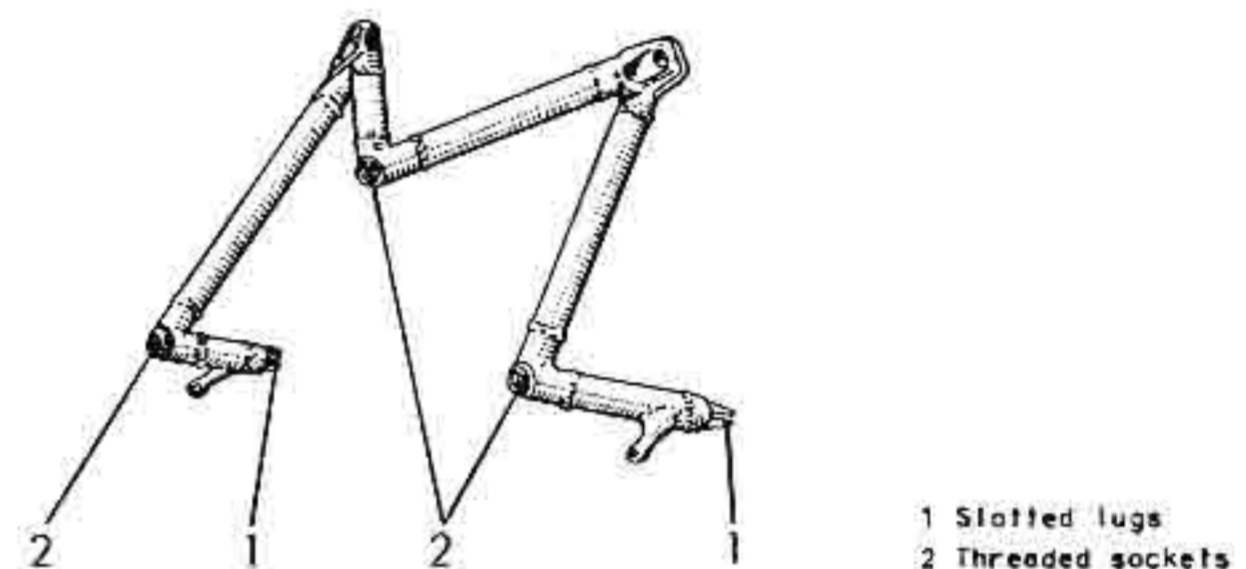

Fig. 7: Engine bearer assembly

The engine bearer assembly, onto which the engine mounting ring is secured, is built up of steel tubing and welded fittings. These fittings include threaded sockets (7,2) for attachment to the engine mounting ring, and slotted lugs (7,1) for attachment to the firewall.

## E. Fuselage fittings

The pilot's seat consists of a Dural pan (8,1) riveted to an armoured back plate (8,2). The seat is attached to the channel sections (8,3) at four points; seat adjustment levers (8,4) are mounted on the upper attachment points. To lock the seat into position, lift the levers; this inserts the lock studs into detents in the slide rails. To release the seat, simply rotate the levers inwards.

A baggage compartment (8,5) is situated behind the

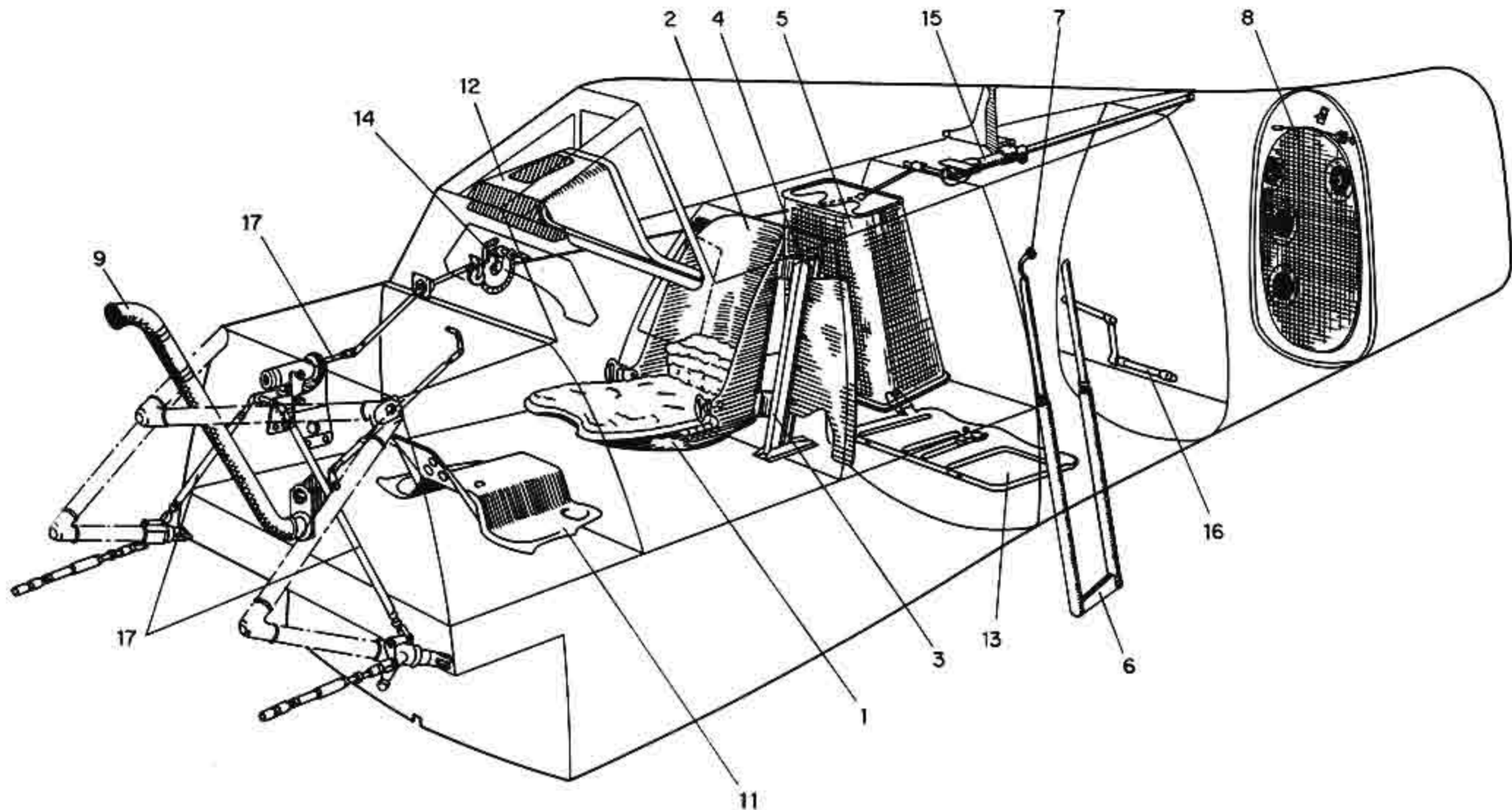

- |                           |                                      |
|---------------------------|--------------------------------------|
| 1 Seat pan with cushion   | 9 Fresh air tube                     |
| 2 Armoured back plate     | 10 Cockpit ventilation actuation rod |
| 3 Seat guide channels     | 11 Fuel tank cover plate             |
| 4 Seat adjustment lever   | 12 Instrument panel cowling          |
| 5 Baggage compartment     | 13 Equipment bearer unit             |
| 6 Cockpit entrance ladder | 14 Canopy drive unit                 |
| 7 Ladder extension button | 15 Canopy jettison mechanism         |
| 8 Fabric panel            | 16 Starter crank                     |
|                           | 17 Cooling flap actuation gear       |

Fig. 8: Fuselage fittings

pilot's seat.

A retractable entrance ladder (8,6) is positioned on the fuselage left side. It is locked in the retracted position by a spring-loaded lever in the ladder guide rods. To lower the ladder, depress the ladder extension button (8,7).

Fresh air enters the cockpit through a ventilation tube (8,9). A valve, positioned on the firewall, permits full adjustment of the air flow. A rod leads from the valve to a lever on Bulkhead 3; the lever is actuated by the right foot.

For the functioning of the cooling flap actuation rods, see Part 7.

## F. Fuselage covering

The fuselage covering comprises the units listed in Fig. 9 (see the following page).

When the aircraft is trestled, secure the fuselage

armament cover (9,5) against inadvertent closing by hooking the shoulder straps onto it.

The wing-root armament doors (9,3) are held open by brace struts.

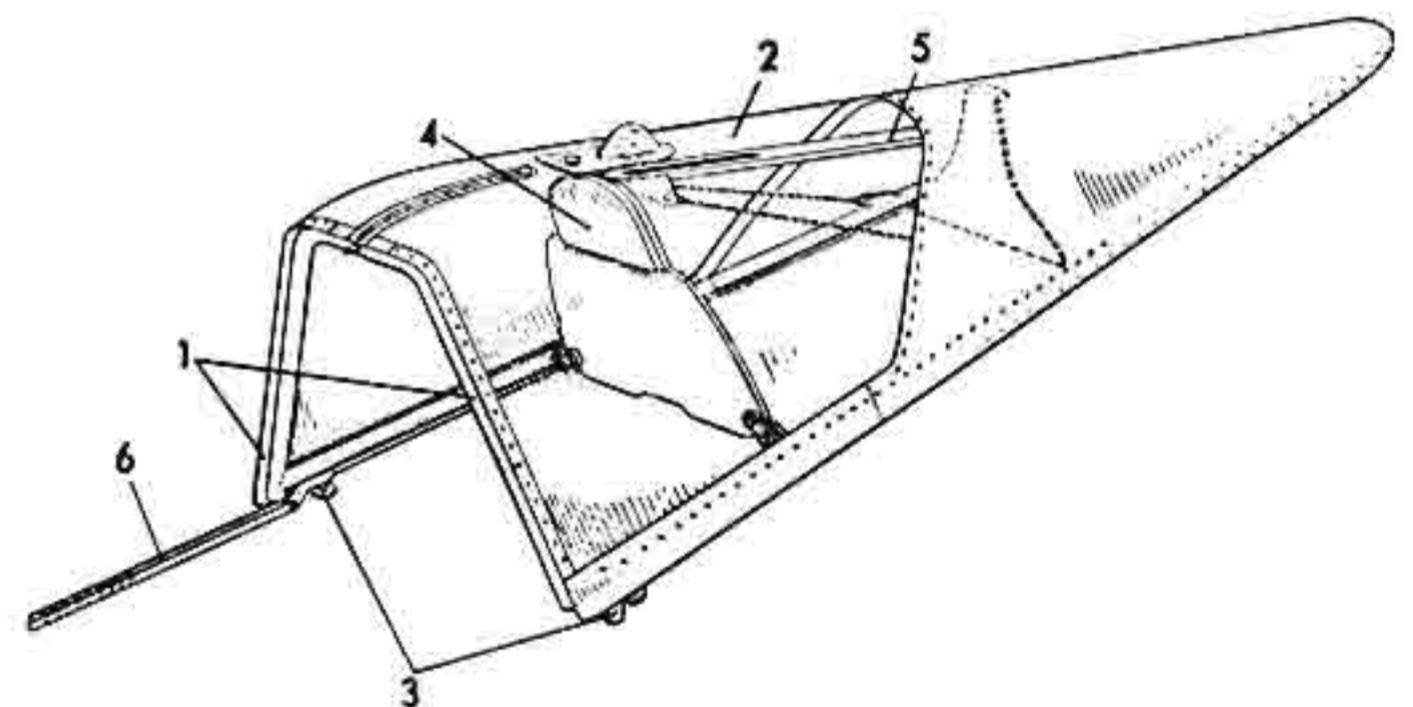

- |                        |                             |
|------------------------|-----------------------------|
| 1 Steel framework      | 4 Head armour               |
| 2 Plexiglass panelling | 5 Head armour support strut |
| 3 Rollers              | 6 Canopy drive section      |

Fig. 10: Canopy

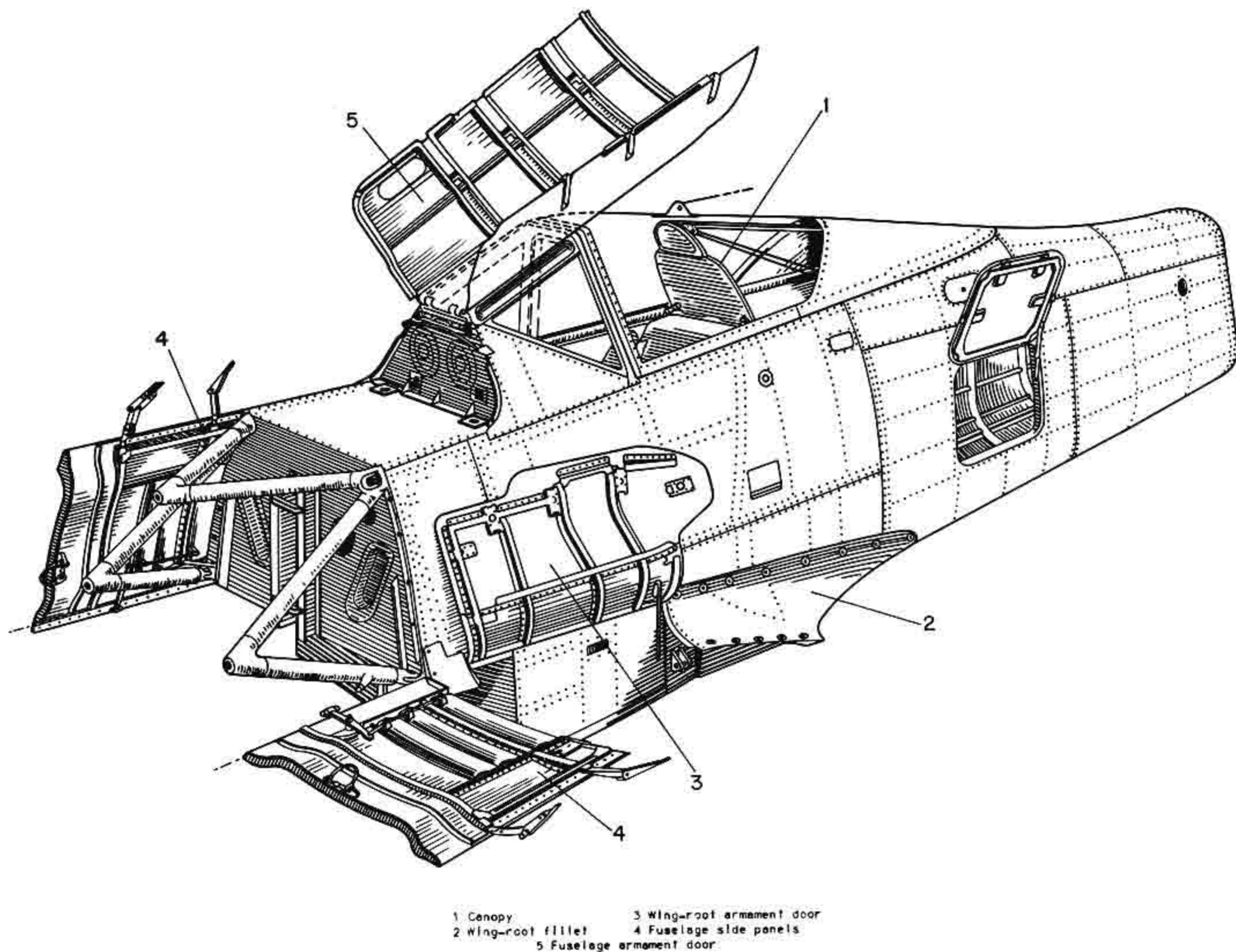

Fig. 9: Fuselage covering

## 1. Canopy

The canopy (Fig. 10) consists of a steel frame (10,1) with Plexiglass panelling (10,2). The unit moves on ball-bearing rollers (10,3) in channels set in the fuselage upper decking. Within the canopy is positioned the head armour (10,4) which is held in place by a steel retaining rod (10,5) and by two cables.

The canopy is opened and closed by a hand crank (11,1), driving a rack-and-pinion gear, located on the cockpit right wall. To prevent the canopy from being moved rearwards beyond the end of the drive section (11,2), its last tooth is located 39 mm (1½ in) from the forward end of the section. At rest, the spring-loaded crank handle is held in place by a stud in the handle (11,3); this stud fits into matching holes arranged around the circumfer-

ence of the circular base plate (11,4). To turn the crank, keep the handle pulled out. The canopy can be opened from outside by simultaneously turning and depressing a spring-loaded, notched thumb screw, positioned over the crank axle on the fuselage right side.

The canopy is jettisoned by an explosive charge (11,12) which is actuated by firmly depressing the red jettison lever (11,5). As the lever is depressed, it causes a bushed strut (11,20) to raise the hood drive section (11,2) from the pinion wheel (11,6); and simultaneously rotates the safety pawl (11,10) to release the firing pin (11,11).

The outer tube (11,13) of the jettisoning mechanism is attached to the rear of the canopy. It contains the inner, or firing, tube (11,14) which is fitted with three sealing rings to maintain a tight fit. The outer tube which serves as the canopy guide

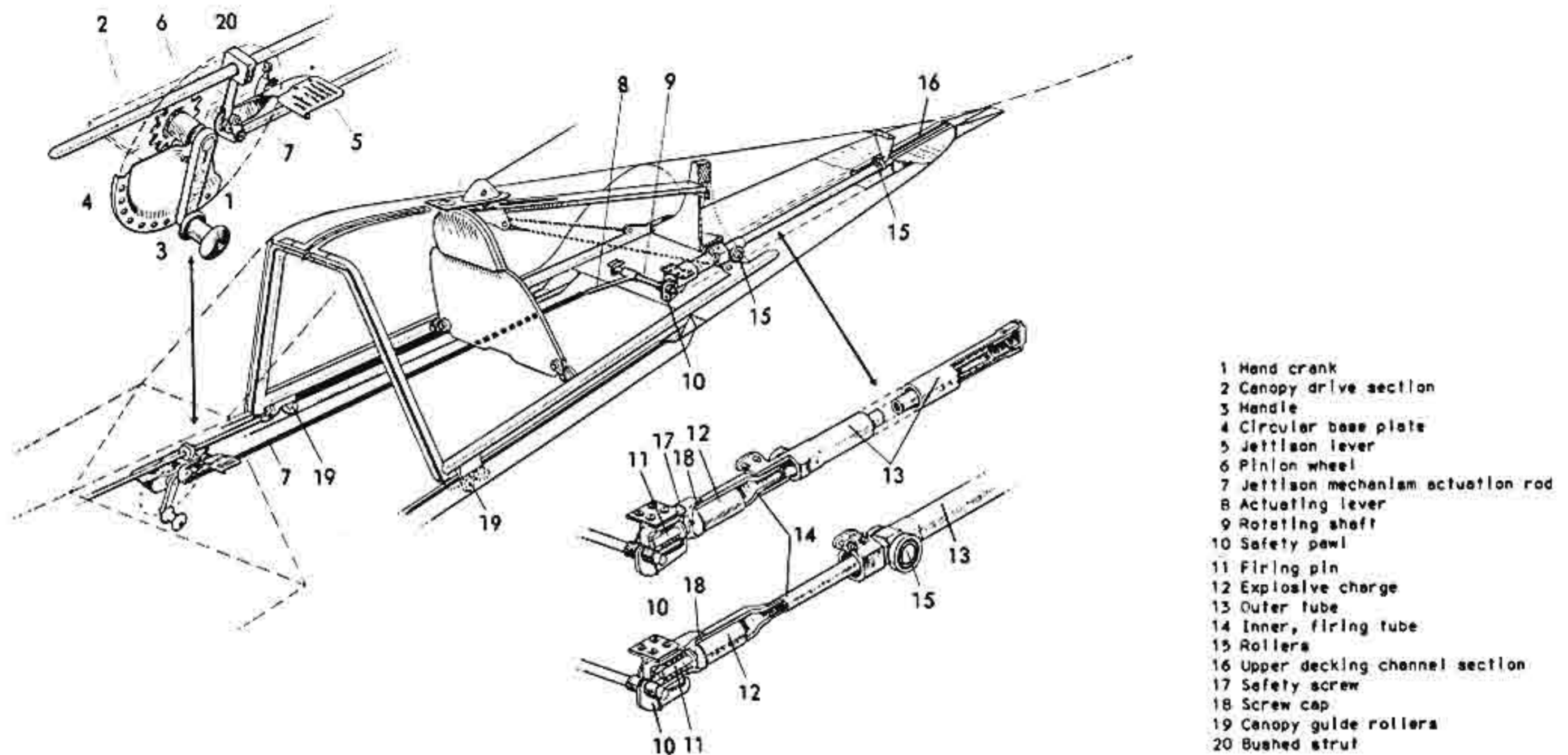

Fig. 11: Canopy jettison mechanism

during normal opening and closing, is fitted with two rollers (11,15) which move inside the upper decking channel section (11,16).

If the aircraft is to remain on the ground for any length of time, safety the jettison mechanism with a wing screw (11,17).

## 2. Fuselage side panels

By hooking the attached cables to the engine bearer assembly, the side panels (9,4) can be positioned horizontally. When so positioned they must not be stepped on.

### Opening and closing the side panels

By opening or closing these panels in an incorrect sequence, one can, in tightening the screw lock (12,4), exert a force sufficient to either distort the panel rivet holes or the panel itself. The following sequence **MUST**, therefore, be followed in opening or closing the panels:

To open:

- Open the quick-release fastener (12,1) and the toggle clips (12,2);
- Loosen the screw lock (12,4). The hook (12,3) will automatically spring out of its guide.

To close:

- Lightly position the panel; then with the head of the screw, probe for its attachment base;

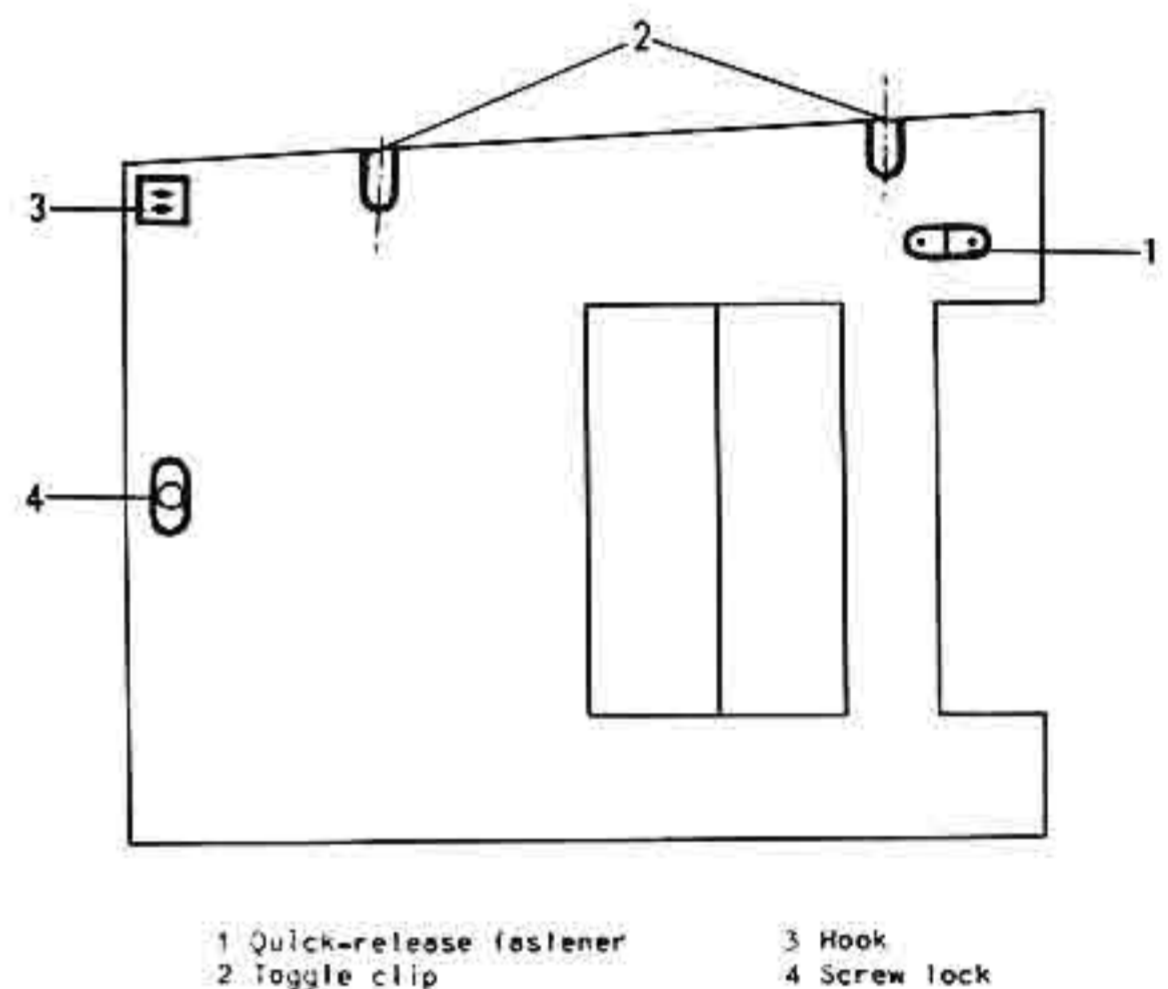

Fig. 12: Fuselage side panel

- Place the two clips in position, but don't lock them. Leave the quick-release fastener open;
- Turn the screw lock until further rotation becomes difficult. At this point the panel has the required tension;
- Give the corner of the panel over the hook a solid blow of the fist to force the hook over a rounded horn on the engine mounting ring;
- Rotate the screw lock until its tight; then lock the clips and the fastener.

## **G. Equipment**

### **1. Radio installation**

The radio gear is located in the forward fuselage between Bulkheads 6 and 8. A hinged panel on the fuselage right side provides access for equipment adjustment.

This gear is provided with two antenna units; one, a T-shaped wire, stretches between the vertical stabilizer and the sliding canopy, entering the rear upper fuselage via a frequency matching device; the second, a fixed rod, is located beneath the left inner wing panel.

### **2. First aid kit**

The first aid kit is contained in a holder on the fuselage right side. Access to it is provided by a hinged cover secured by quick-release fasteners.

### **3. Oxygen bottles**

The Oxygen equipment consists of three sets of spherical steel bottles, all mounted on a rack in the equipment bay.

### **4. Flare pistol**

The flare pistol is secured by a rubber sleeve mounted on the cockpit right side at Bulkhead 3. Its ammunition is stored beneath the right instrument console.



**D. (Luft) T. 2190 A-8**

**For Official Use Only!**

# **Fw 190 A-8**

**Aircraft Handbook**

**Part 2**

**Undercarriage**

**(Effective July 1944)**

**Issued September 1944**



# I. Description

## A. Main undercarriage unit

### 1. General

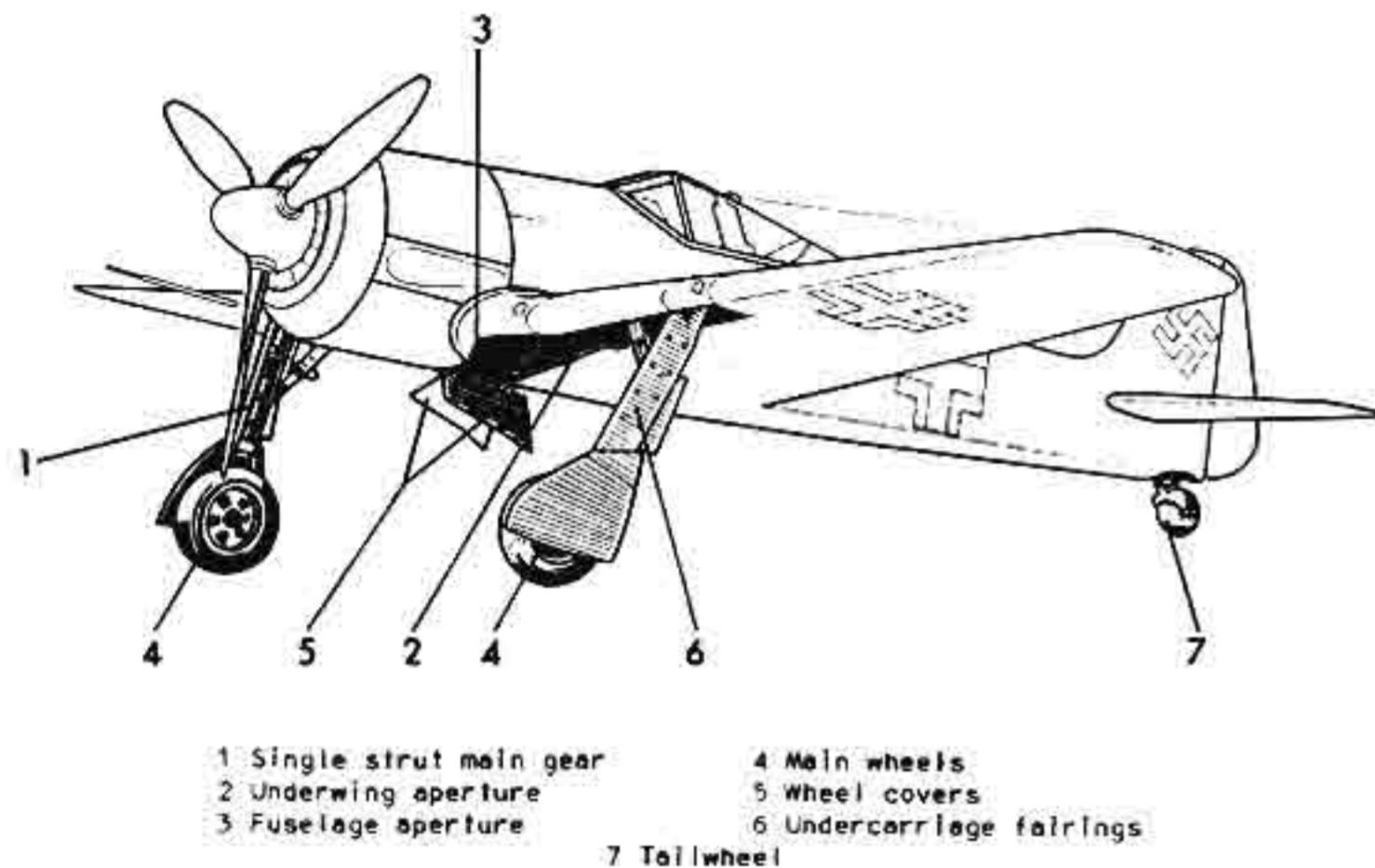

Fig. 1: Undercarriage unit

The aircraft has a two strut main undercarriage unit (1,1) which is mounted on the main spar and retracts inwards. When retracted, the unit fits into apertures in the undersides of the wing (1,2) and the fuselage (1,3). The fuselage apertures are either fully covered by hinged doors (1,5), or, when an ETC 501 rack is fitted, partially covered by fixed panels. The underwing apertures are sealed by fairings (1,6) attached to the undercarriage struts.

The main gear is both retracted and extended electrically. A cable attached to the right undercarriage member causes the tailwheel (1,7) to retract simultaneously with the main gear.

### 2. Main unit construction

The main gear consists of two EC-oleo shock struts (2,1) which have, at their upper ends, right-angled, tapered mounting assemblies (2,2); and at their lower ends, housings (2,3) for the cantilever axles. A scissors unit (2,4) connecting the upper and lower shock strut members, absorbs torque stresses and ensures proper main gear tracking.

Each main gear strut is retracted and extended individually by a rotating drive unit (2,5) powered by an electric motor (2,6); bolted together, they are mounted on the main spar.

To retract the main gear, the drive unit rotates the upper radius rod (2,7) which pulls up the lower

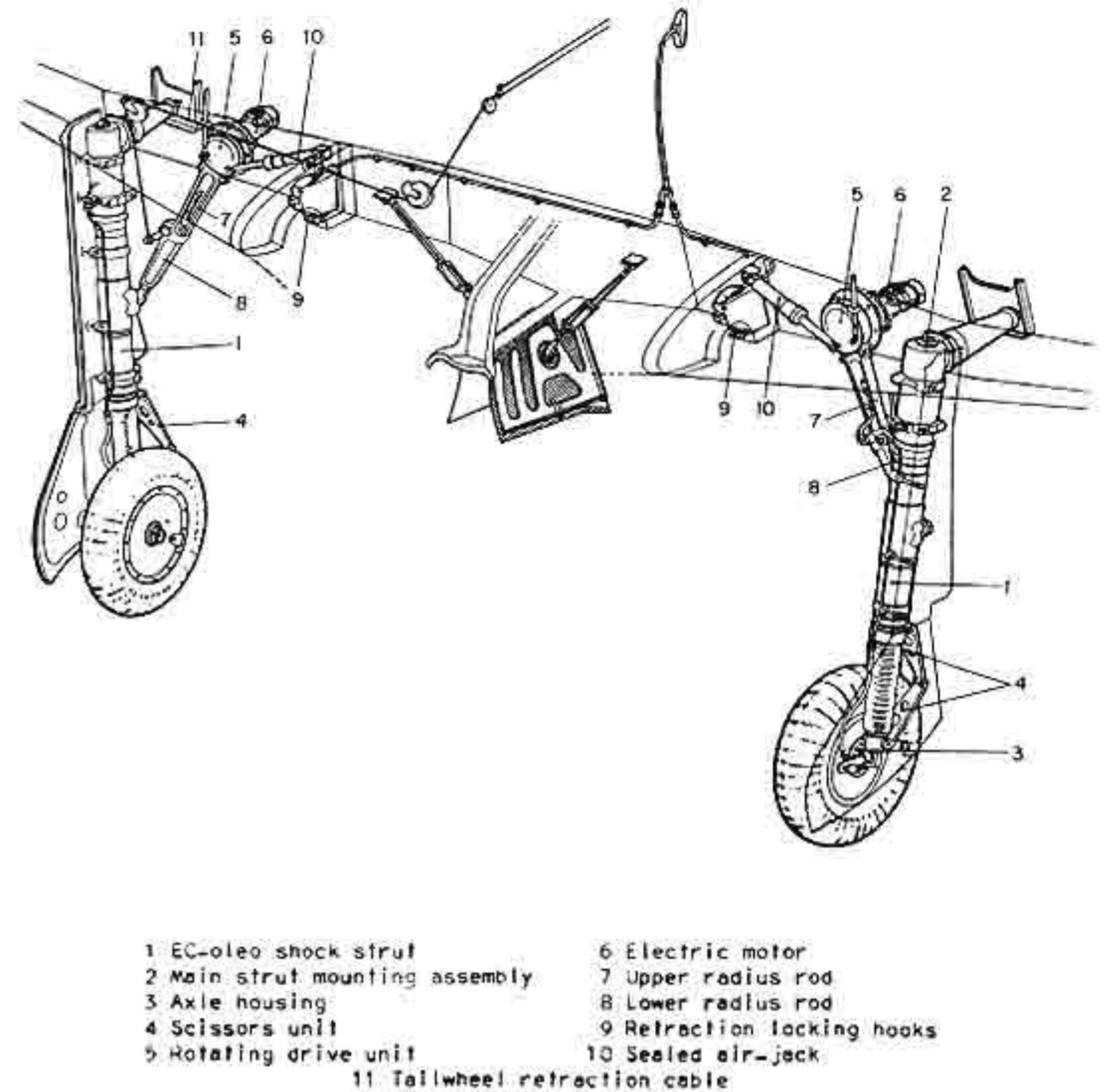

Fig. 2: Main gear unit (with wheel doors fitted)

radius rod (2,8) and with it the shock strut (2,1). The main gear members are secured in the retracted position by powerful locking hooks (2,9).

A sealed air-jack (2,10) is attached, at one end, to the drive unit and, at the other end, to an attachment point within the wing leading edge. During retraction it is compressed; subsequently, aiding in the undercarriage lowering. In the event of electrical failure it ensures full undercarriage extension.

The tailwheel retraction cable (2,11) is attached to a rod on the right shock strut radius rod hinge point.

### 3. Up-lock mechanism

The main gear up-lock mechanism consists of two locking units (3,1), spurs on each shock strut (3,2), and a DUZ-flexible cable (3,3).

The operation of the up-lock system is described below.

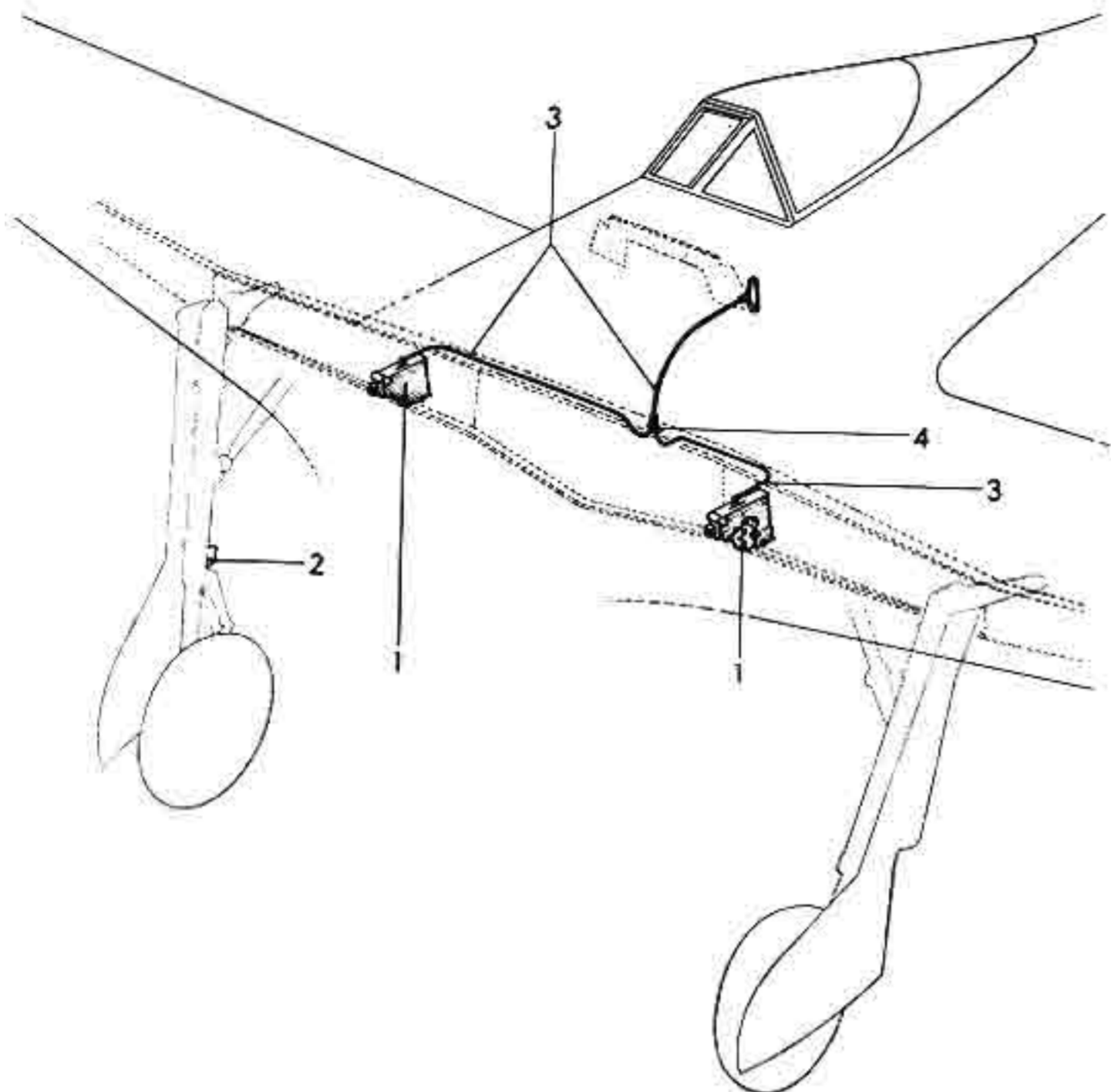

1 Locking unit      3 DUZ-flexible cable with handle  
2 Spur              4 Shackle

Fig. 3: Locking mechanism

#### 4. Operation

Undercarriage operation is controlled by push buttons located on the cockpit left instrument console (4,1). The undercarriage retraction button is secured against accidental activation by a safety cover (4,2).

##### Undercarriage retraction

After attaining the required minimum altitude, retract the undercarriage by flipping up the red safety cover over the 'Ein' button and depressing that button. This causes the locking hooks to open and the electrical drive motors to start raising the gear. In the last portion of the retraction cycle, the shock strut spurs come in contact with the locking unit hooks which are then forced up and locked in place; securing the undercarriage and simultaneously switching off the electrical motors. This position is indicated by the illumination of the red lights on the undercarriage indicator unit.

In addition to the electrical monitoring of the gear position there is also mechanical monitoring, in the form of an indicator rod (5,1) for each strut. The top of the rod is flush with the wing upper surface when the gear is retracted.

##### Undercarriage extension

To lower the undercarriage, depress the 'Aus'

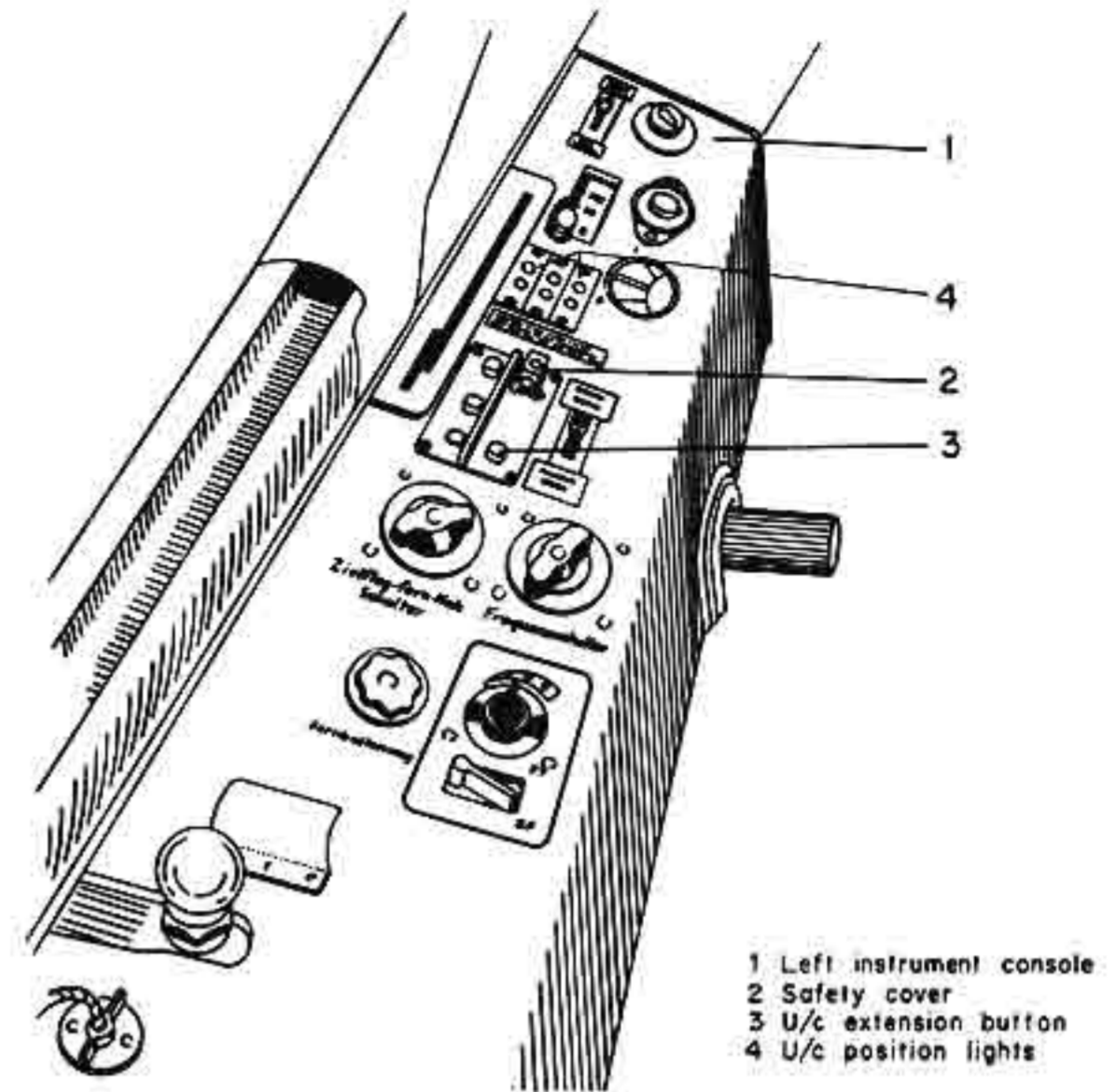
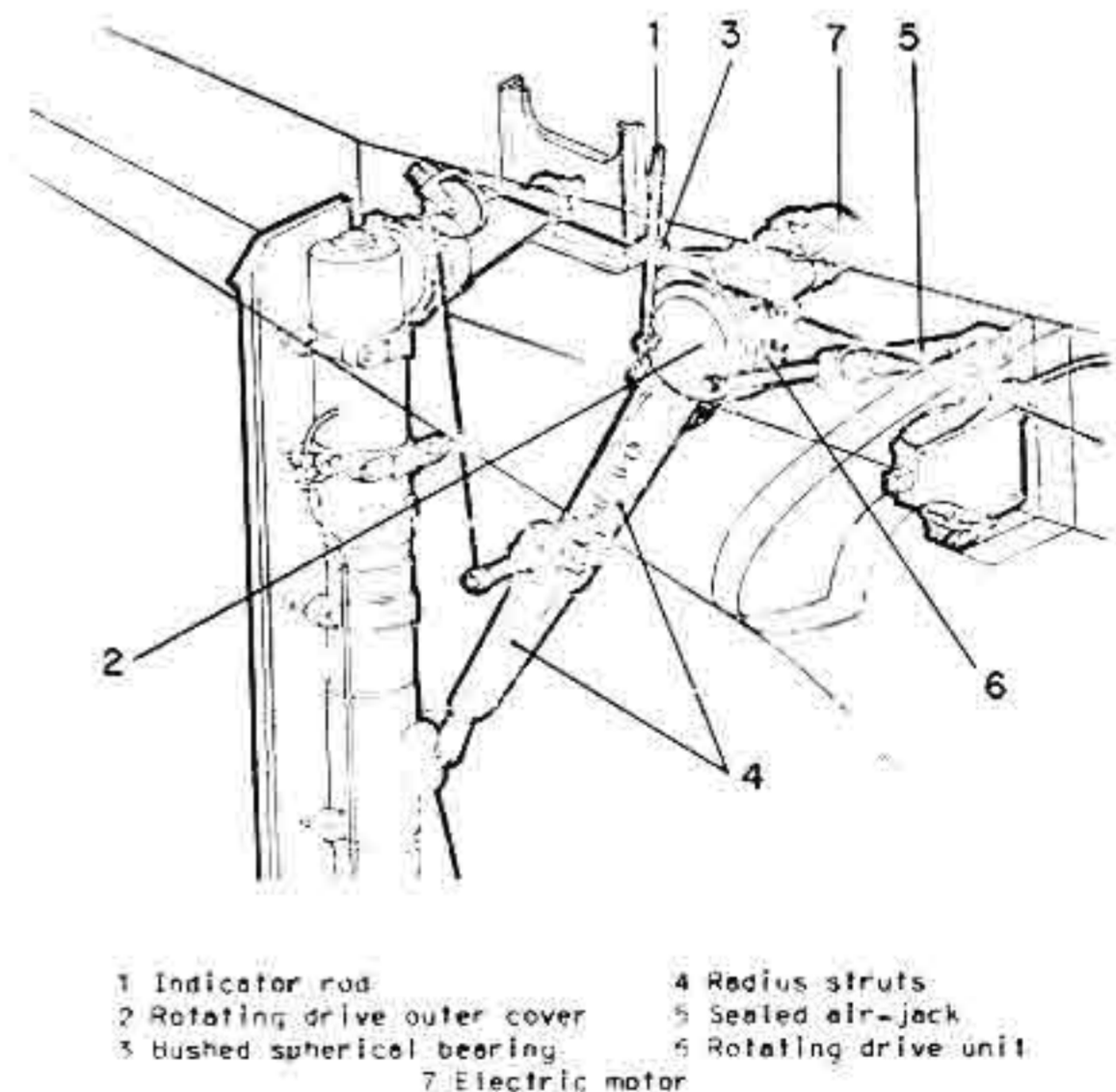

Fig. 4: Undercarriage controls

button. This causes the locking unit hook to open, releasing the undercarriage legs, and starts the electric motors. When the gear is fully extended and locked down, a microswitch on each upper radius rod automatically switches off the drive motors. This position is shown by the illumination of the green lights on the undercarriage indicator unit.

The indicator rod (5,1) shows full main gear extension when the white band at its base becomes visible. While only the red portion of the rod shows, the gear is in an unsafe condition.

The indicator rod (5,1) is attached to the rotating



1 Indicator rod      4 Radius struts  
2 Rotating drive outer cover      5 Sealed air-jack  
3 bushed spherical bearing      6 Rotating drive unit  
7 Electric motor

Fig. 5: Indicator rod mechanism

drive outer cover (5,2), and is led through the wing upper skin by a bushed spherical bearing (5,3).

#### Emergency undercarriage extension

In case of failure of the electric motor, the main gear can be lowered by pulling the emergency gear extension handle. This manually unlocks the shock struts, which, with the help of gravity and the sealed air-jacks, then fully extend. If the electrical monitoring circuitry is also unserviceable, ensure that the white bands on the indicator rods are visible.

### 5. Main tires

The aircraft main tires measure 700 x 175 mm with 300 mm diameter brakes.

### 6. Braking system

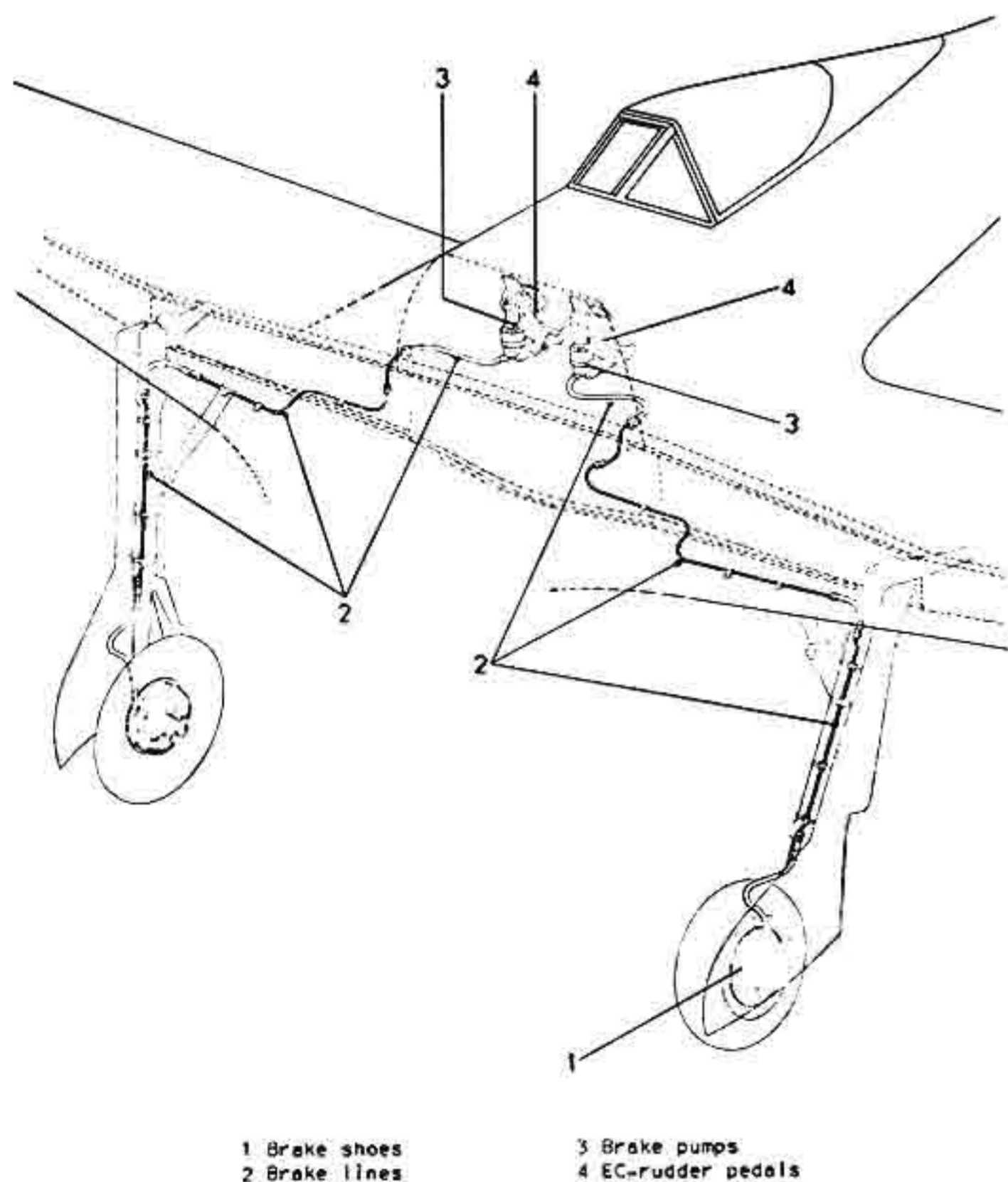

1 Brake shoes  
2 Brake lines  
3 Brake pumps  
4 EC-rudder pedals

Fig. 6: Braking mechanism

The braking system consists of a hydraulically actuated brake shoe (6,1) on each main wheel, brake lines (6,2), and a hydraulic pump (6,3) attached to each EC-rudder pedal (6,4).

The wheels can be braked individually. The brakes are energized by toe pressure on the rudder pedals;

causing hydraulic fluid to move down the lines to the brake shoe servos, forcing the shoes against the brake drums. Removing pressure from the brake pumps releases the brakes. The brakes operate on the Duo-Servo-Principle.

### 7. Undercarriage fairings & wheel doors

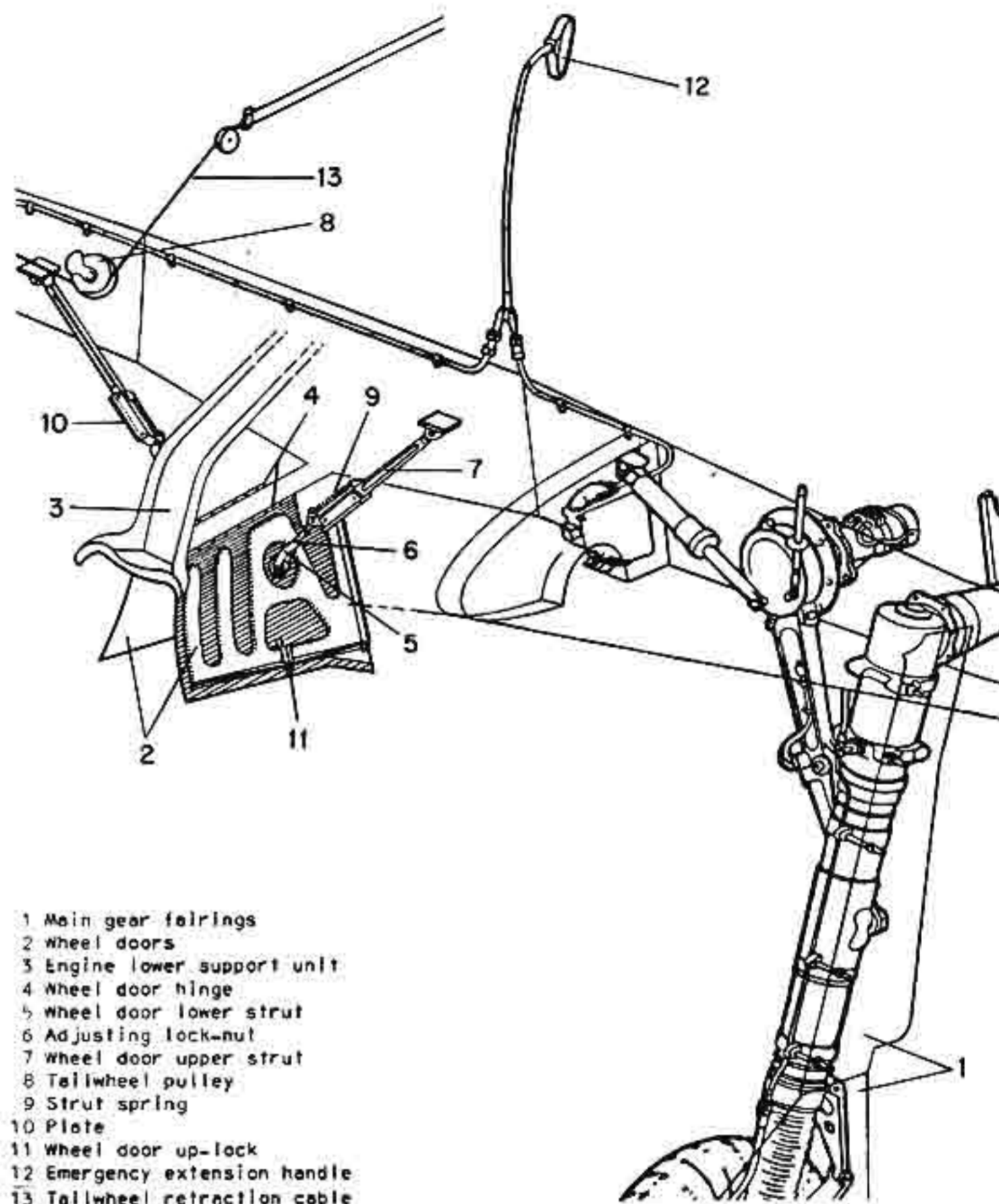

1 Main gear fairings  
2 Wheel doors  
3 Engine lower support unit  
4 Wheel door hinge  
5 Wheel door lower strut  
6 Adjusting lock-nut  
7 Wheel door upper strut  
8 Tailwheel pulley  
9 Strut spring  
10 Plate  
11 Wheel door up-lock  
12 Emergency extension handle  
13 Tailwheel retraction cable

Fig. 7: Wheel door actuation unit

The apertures in the undersides of the wing and fuselage are fully sealed, upon undercarriage retraction, by two-piece fairings (7,1 and Fig. 8) fixed to the shock struts, and by hinged wheel doors (7,2) (fixed fairings are substituted for the doors when an ETC 501 rack is fitted).

The wheel doors (7,2) are attached by hinges (7,4) to the engine lower support unit (7,3), and are opened and closed mechanically by the movement of the main gear.

While the undercarriage is extended, the wheel doors (7,2) are kept open by the tension of the spring (7,9) connecting the wheel door struts (7,5 and 7). During the final phase of undercarriage retraction, the mainwheel presses up against a plate (7,10) on the underside of the upper strut (7,7) forcing the

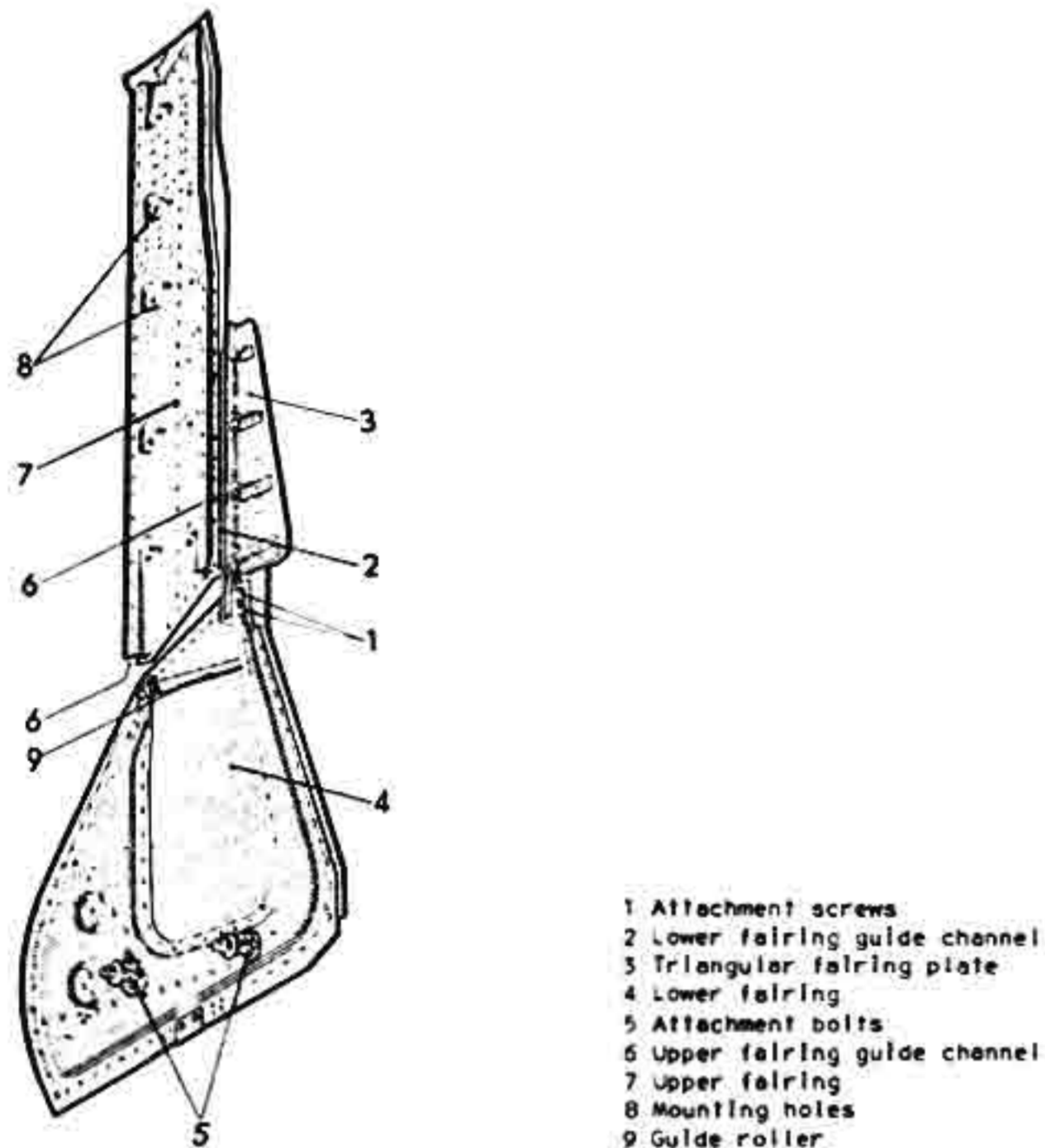

Fig. 8: Right undercarriage fairings (Inner)

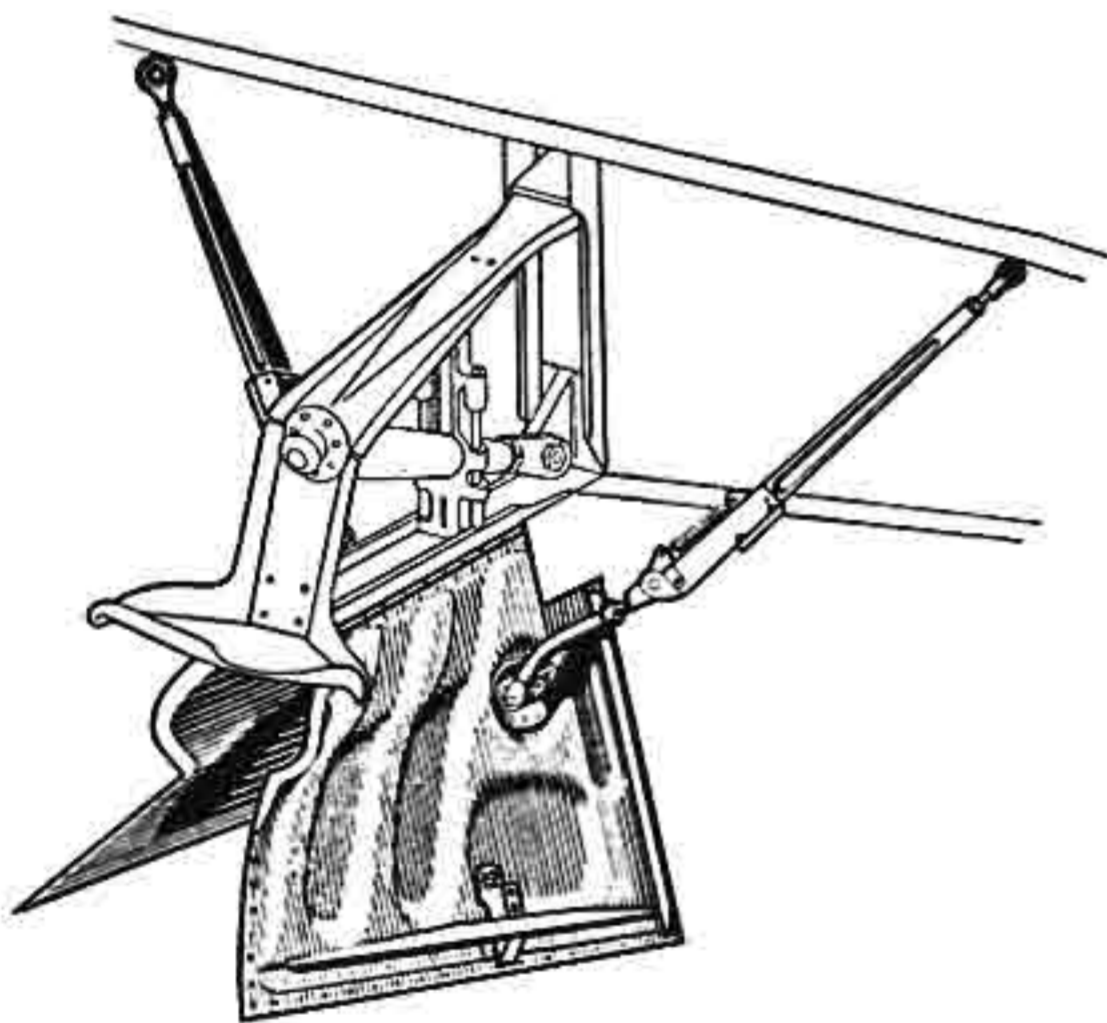

Fig. 8a: Wheel doors

the wheel door to close. The door is locked up by a spring-loaded catch (7,11) which engages the main gear lower fairing (8,4) (See also Fig. 9).

During undercarriage extension, the action of the strut spring (7,9) forces open the wheel doors.

When an ETC 501 undercarriage rack is fitted, the wheel doors are replaced by wheel fairing plates (wheel door struts are also removed). To decrease the uncovered area over the wheels caused by the

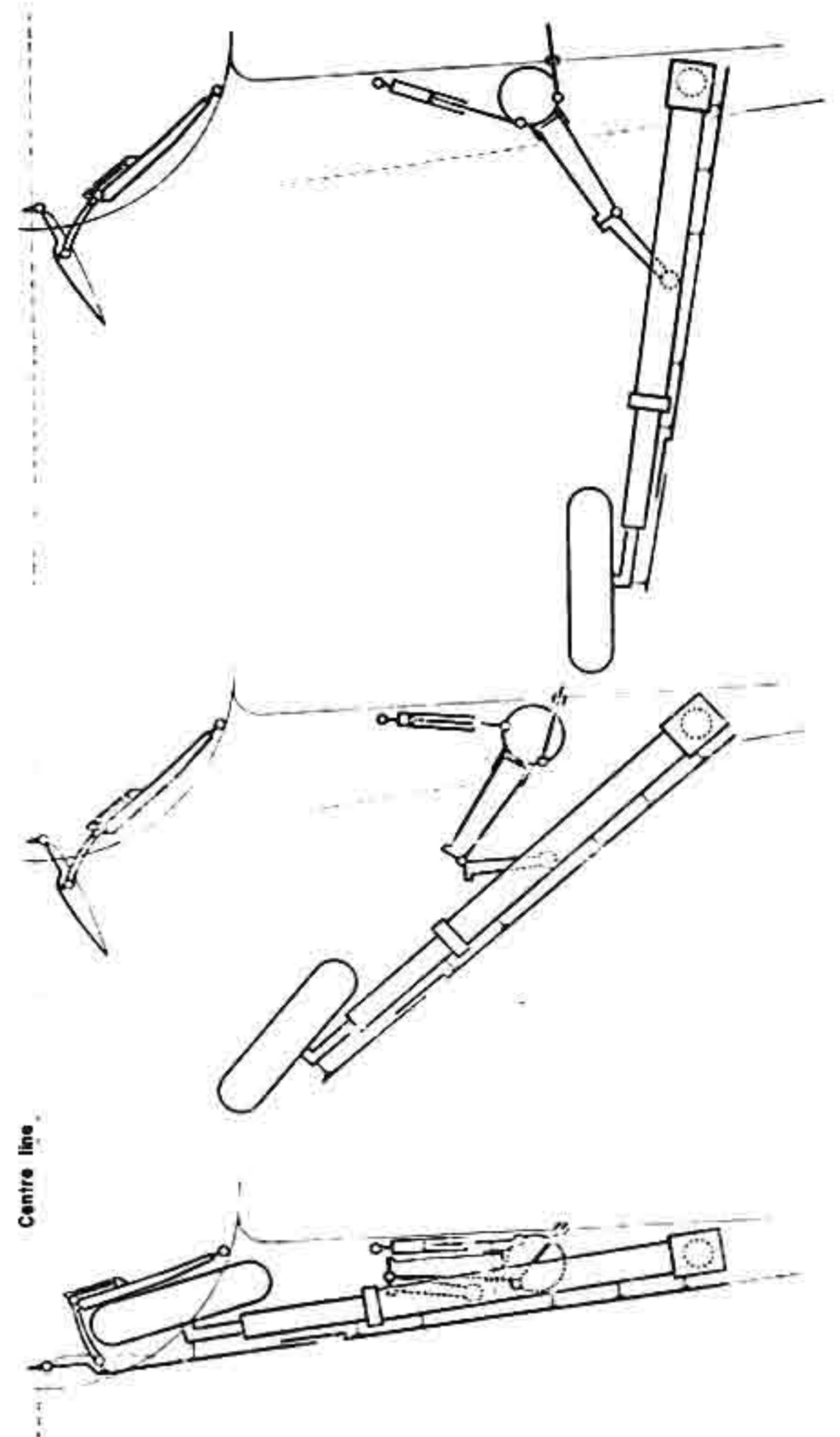

Fig. 9: Wheel door positions during retraction

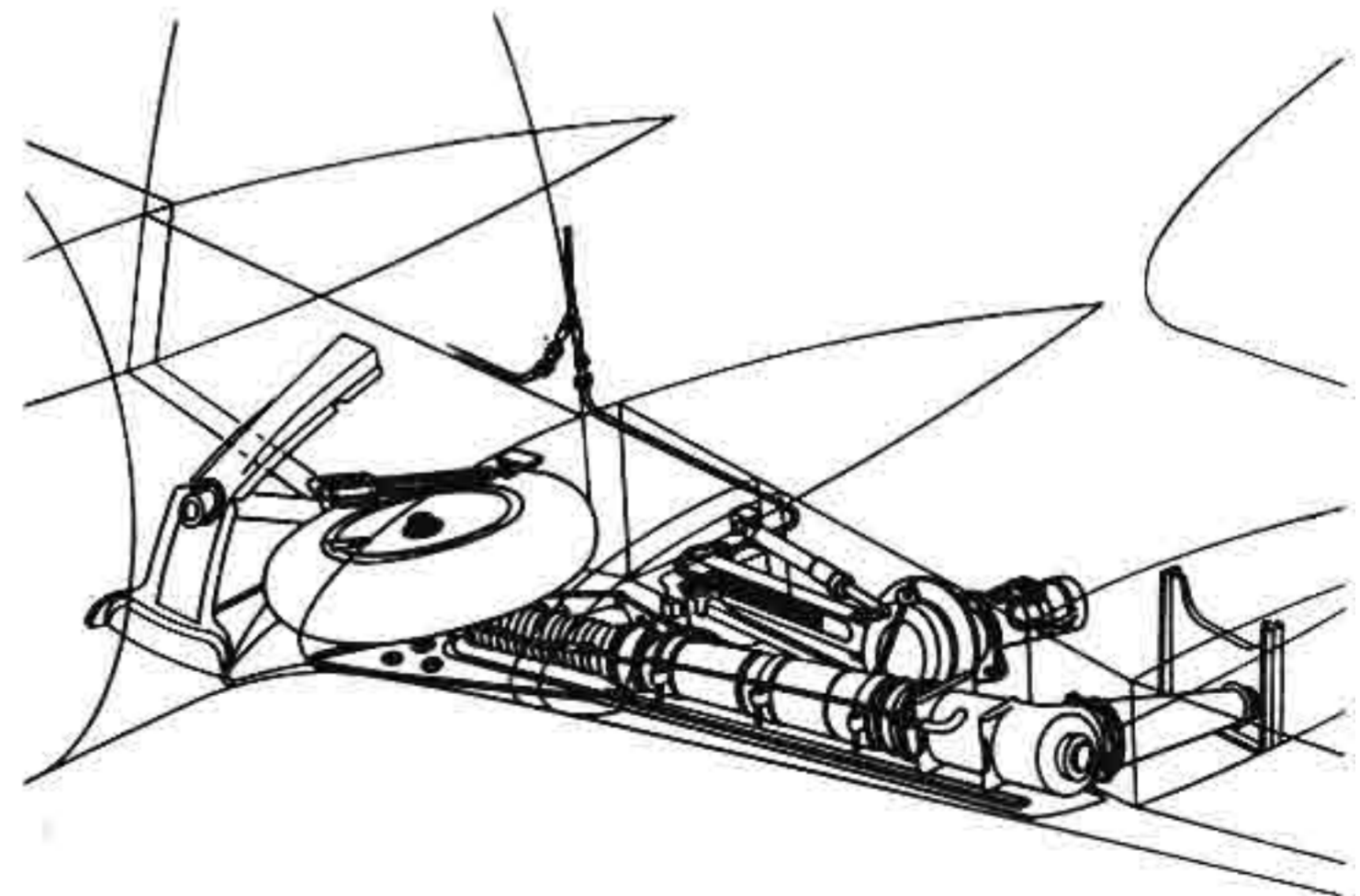

Fig. 10: Undercarriage (left) retracted

removal of the wheel doors, the main gear fairings (7,1) are lengthened by screwing an extension piece onto the bottom of the lower fairing (8,4).

## B. Tailwheel

### 1. General

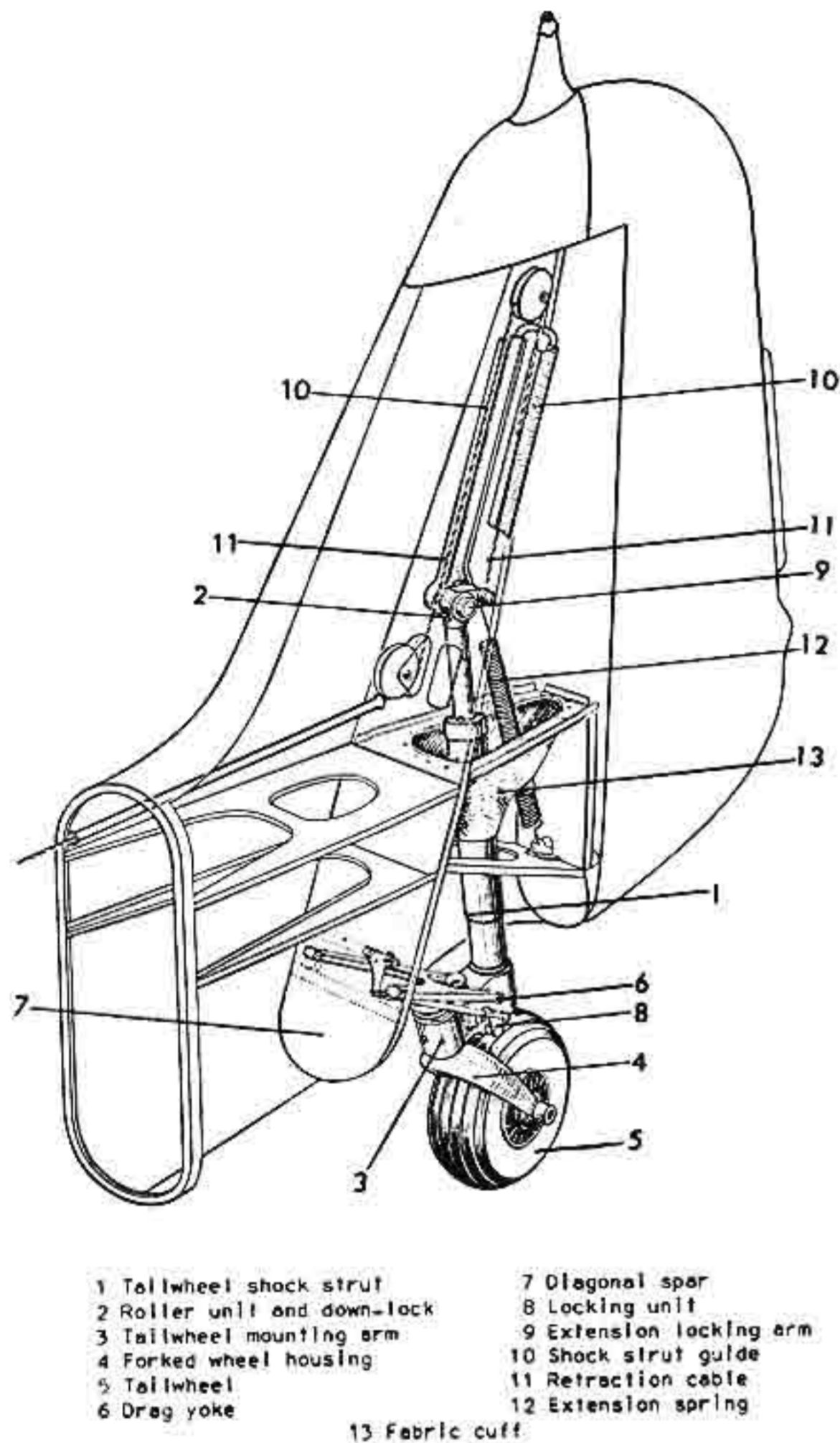
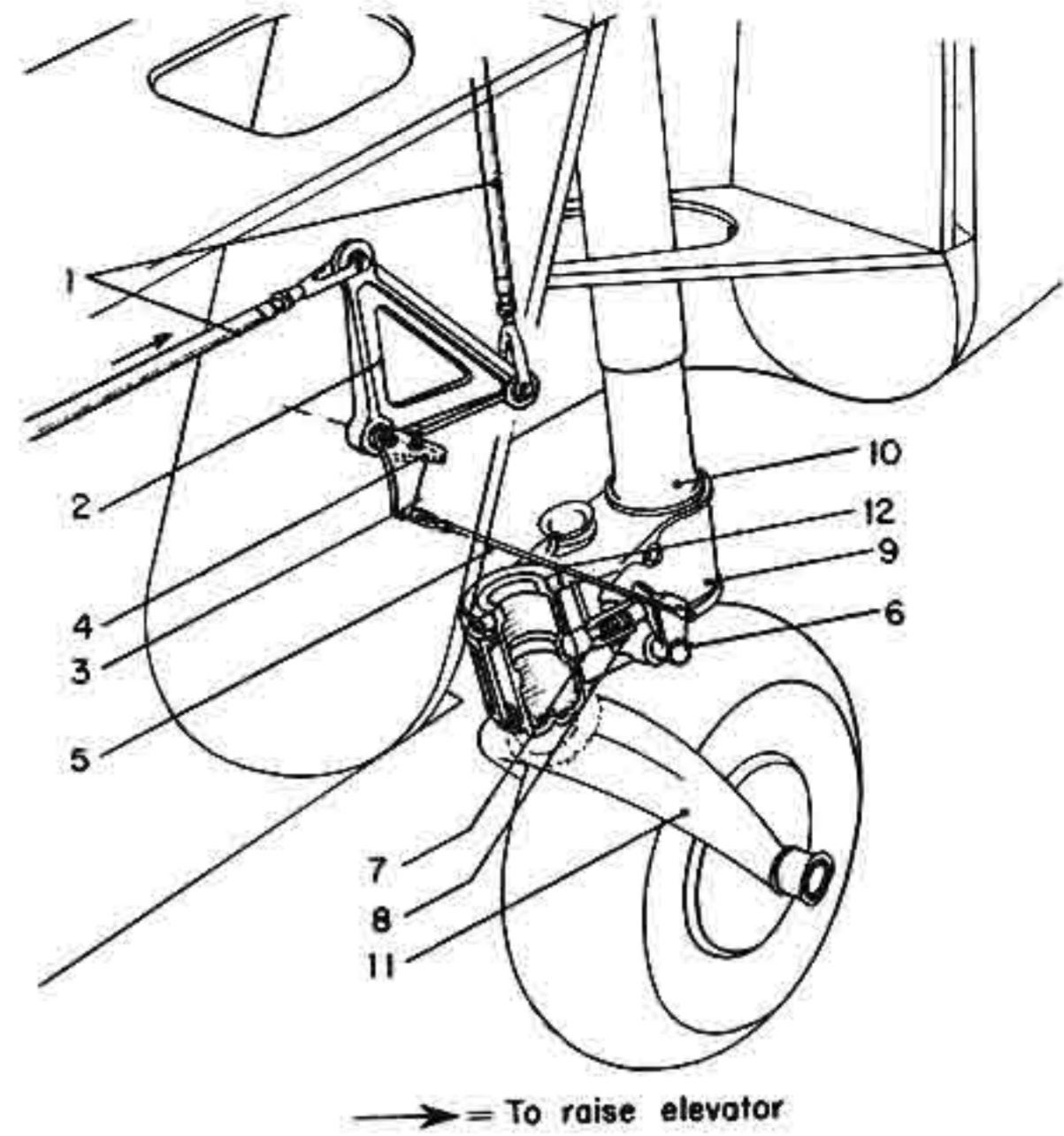

Fig. 11: Tailwheel extended

The tailwheel is retracted simultaneously with the main gear by a tailwheel retraction cable attached to the right undercarriage leg which raises it into the vertical stabilizer and holds it there.

The tailwheel can be rotated through 360° and has a centering lock.

A fabric cuff (11,13) prevents dirt from entering the upper portion of the tailwheel unit.



- |                              |                          |
|------------------------------|--------------------------|
| 1 Elevator control rods      | 7 Locking bolts          |
| 2 Bell-crank                 | 8 Spring                 |
| 3 Lever                      | 9 Tailwheel mounting arm |
| 4 Set screw                  | 10 EC-shock strut        |
| 5 Locking unit actuation rod | 11 Forked wheel housing  |
| 6 Locking arm                | 12 Return spring         |

Fig. 12: Tailwheel locking unit

### 2. Tailwheel unit construction

The tailwheel unit is composed of an EC-shock strut (11,1) topped by a combination roller unit and down-lock (11,2), a mounting arm (11,3), a forked housing (11,4), and a tailwheel (11,5). A drag yoke (11,6), attached to both the diagonal spar (11,7) and the mounting arm (11,3) by bushed bearings, guides the movement of the tailwheel unit and absorbs horizontal stresses on it. The locking unit (11,8) is linked to the elevator and is activated when the control stick is pulled fully back (see Fig. 12). During take-off this can be used to prevent tailwheel shimmy and possible ground looping. When the tailwheel is extended, the down-lock is wedged into an enlarged cavity at the base of the shock strut guide (13,10). It is held there by the heavy duty spring (13,12) to which it is attached.

During undercarriage retraction, the retraction cable (11,11) pulls the rear end of the down-lock out of the guide cavity—against the force of the spring (11,12)—and up the guide (11,10).

When retracted, the tailwheel is not locked into position, but is held in place by the tension on the retraction cable. The mounting arm (13,3) is drawn up through the drag yoke (13,6) to rest against the diagonal spar (13,7).

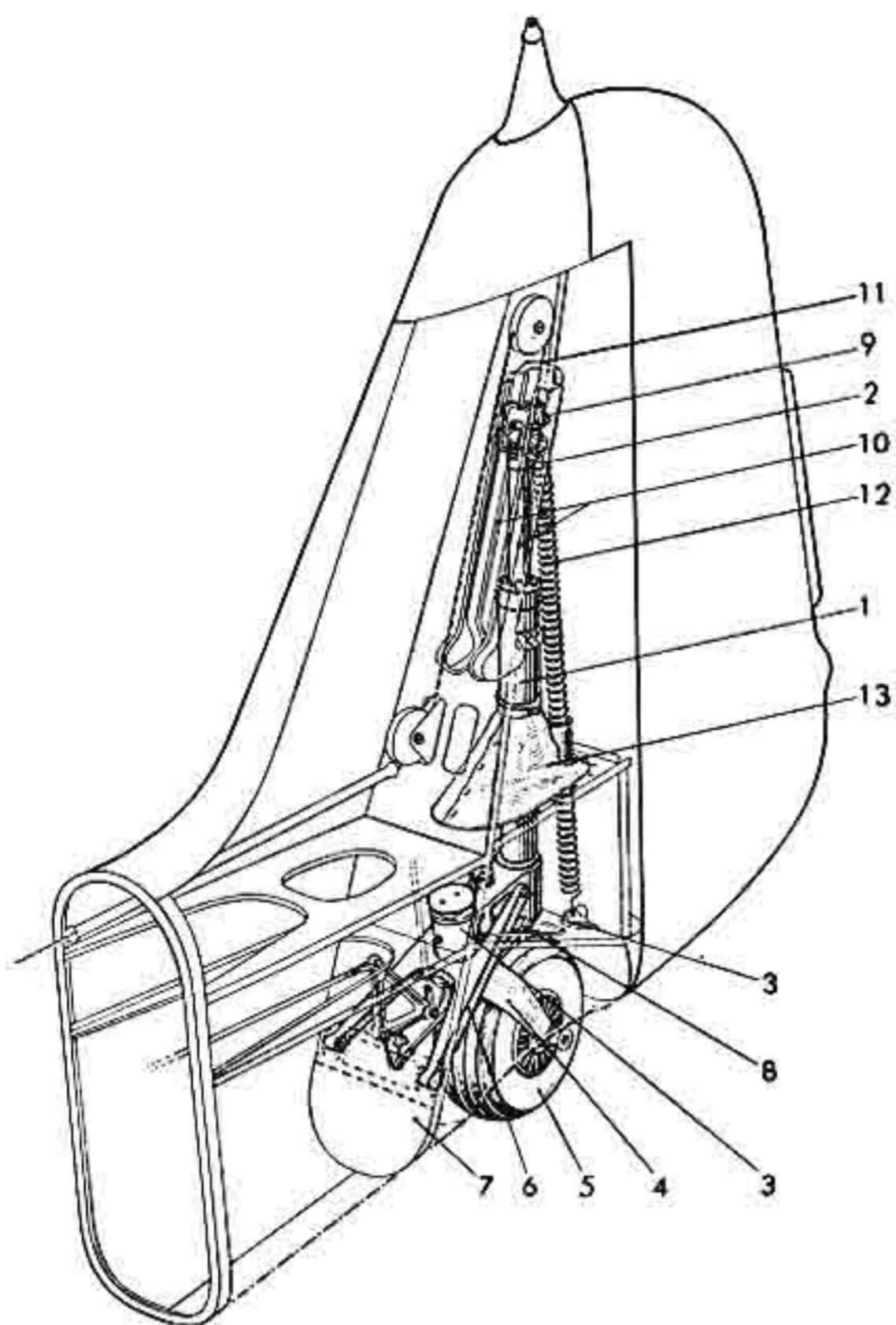

- |                             |                      |
|-----------------------------|----------------------|
| 1 Shock strut               | 7 Diagonal spar      |
| 2 Roller unit and down-lock | 8 Tailwheel lock     |
| 3 Mounting arm              | 9 Locking arm        |
| 4 Forked wheel housing      | 10 Shock strut guide |
| 5 Tailwheel                 | 11 Retraction cable  |
| 6 Drag yoke                 | 12 Extension spring  |
|                             | 13 Fabric cuff       |

Fig. 13: Tailwheel retracted

### 3. Emergency tail skid

When it is retracted, approximately one half of the tailwheel remains exposed and so can serve as an emergency tail skid.

### C. Monitoring unit

The electrical monitoring unit shows the pilot the position of the main gear. Tailwheel position is not monitored.

Microswitches on the main gear radius rods and in the locking unit indicate, through red or green lights, the main undercarriage position.

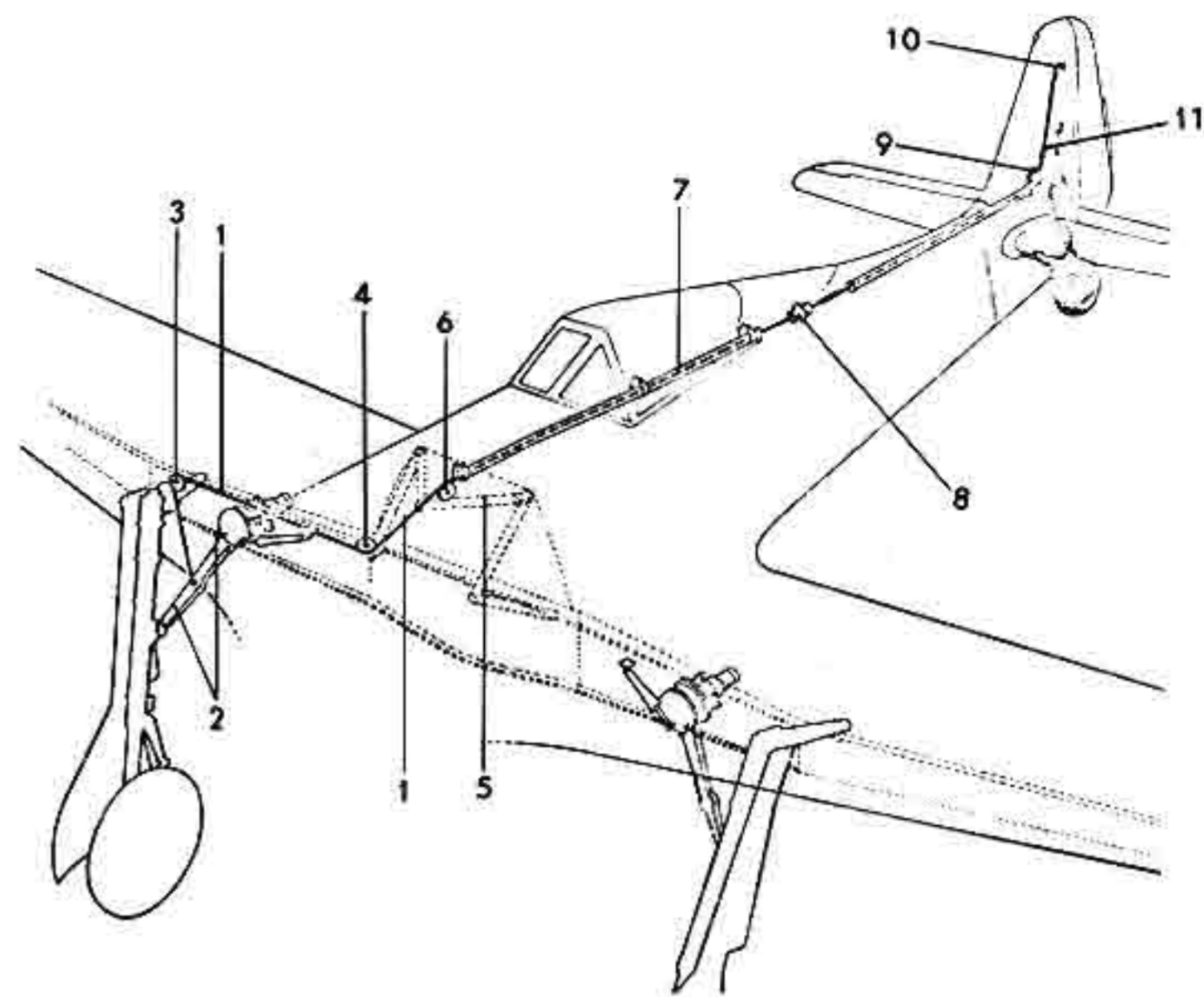

- |                          |  |
|--------------------------|--|
| 1 Retraction cable       | 6 Pulley                               |
| 2 Actuation struts       | 7 Guide tube                           |
| 3 Pulley                 | 8 Bulkhead bushing                     |
| 4 Pulley                 | 9 Pulley                               |
| 5 Engine bearer assembly | 10 Pulley                              |
|                          | 11 Tailwheel roller unit and down-lock |

Fig. 14: Tailwheel retraction system

### D. Additional undercarriage details

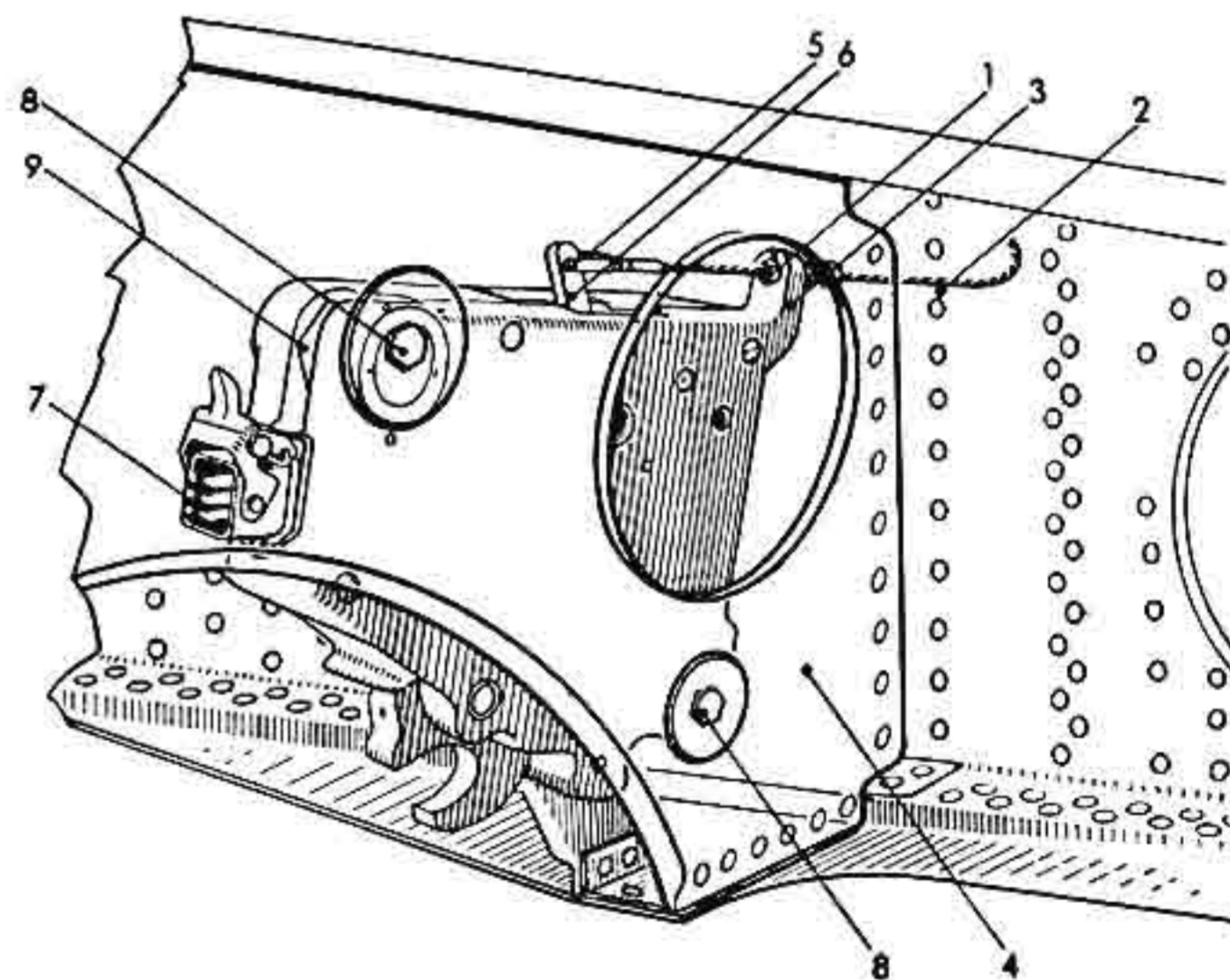

- |                      |                            |
|----------------------|----------------------------|
| 1 Nut                | 5 Split pin bolt           |
| 2 DUZ-flexible cable | 6 Manual release lever     |
| 3 Holder             | 7 Plug connection          |
| 4 Locking unit       | 8 Bolt                     |
|                      | 9 Nut on eccentric bushing |

Fig. 15: Locking unit

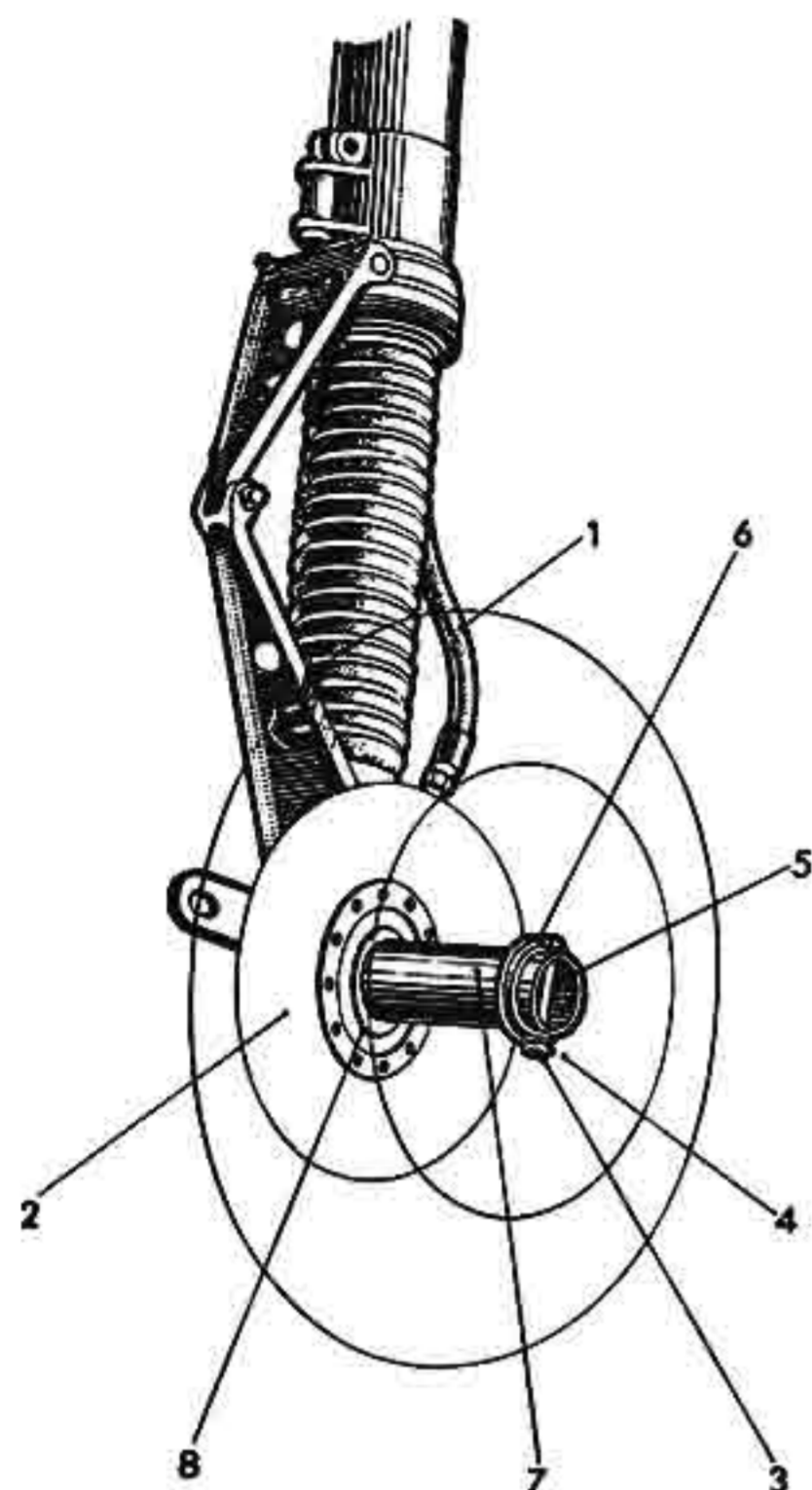

- |                     |                  |
|---------------------|------------------|
| 1 Brake line        | 5 Bolt           |
| 2 Brake cover plate | 6 Retaining ring |
| 3 Cotter pin        | 7 Axle           |
| 4 Crown nut         | 8 Axle flange    |

Fig. 16: Main gear lower strut

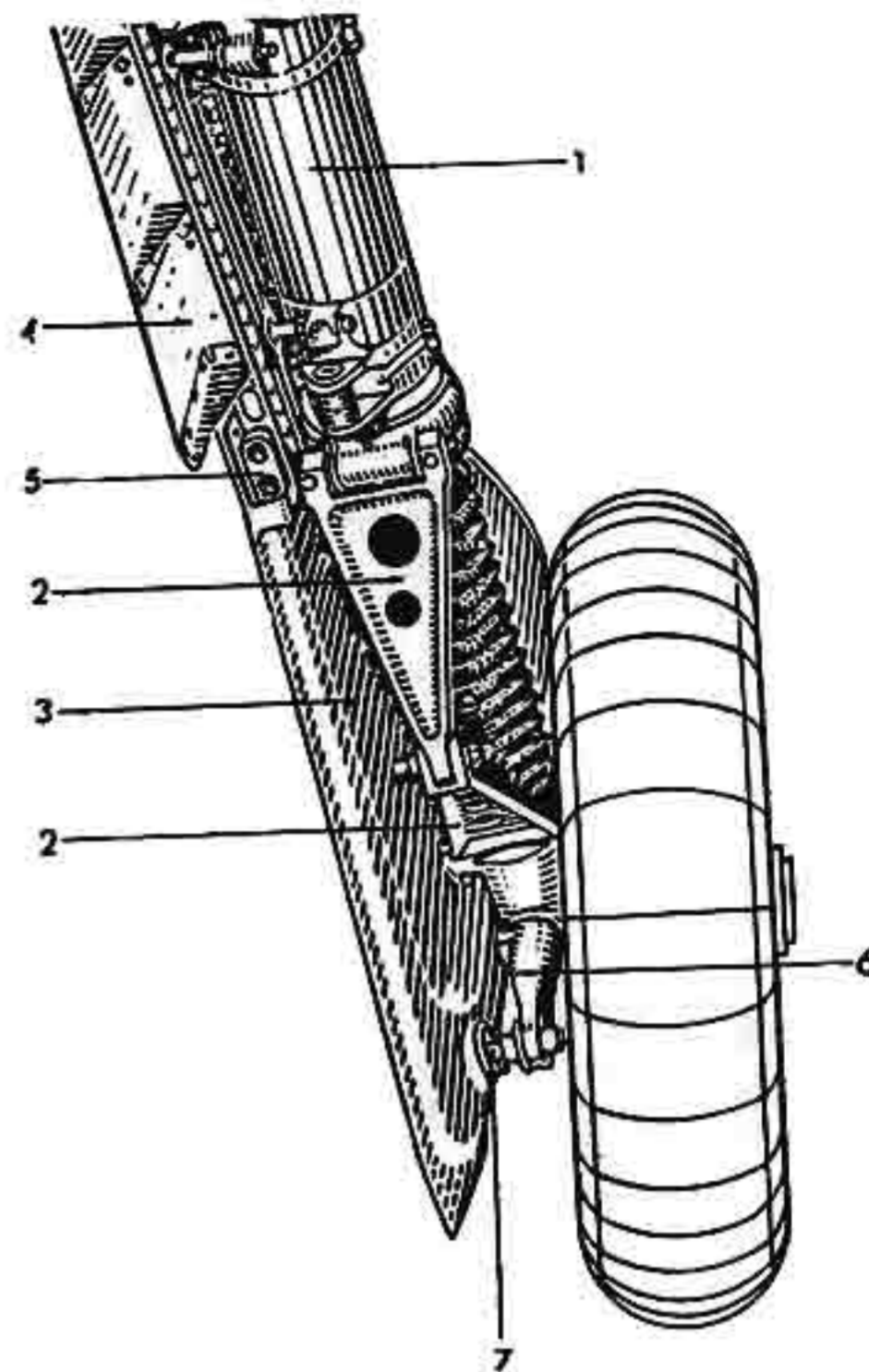

- |                 |                                       |
|-----------------|---------------------------------------|
| 1 Shock strut   | 4 Triangular fairing plate            |
| 2 Scissors unit | 5 Guide channel attachment point      |
| 3 Lower fairing | 6 Lower fairing attachment outriggers |
|                 | 7 Attachment bolts                    |

Fig. 17: Lower fairing attachment

## II. Inspection

- 1) Ensure the main gear and tailwheel tire pressures are as shown in the following table:

Take-off weight up to kg (lbs)	Mainwheels		Tailwheel	
	atu	psi	atu	psi
4300 9500	5,00	73.7	4,75	70.0
4600 10170	5,25	77.3	5,00	73.7
4900 10830	5,50	81.0	5,00	73.7

During hot weather, ensure that the stated tire pressures are not exceeded by more than 0,3 atu (4.4 psi). Check for tire creep by comparing the red marks on the tire and rim. More than 8 mm displacement is not permitted!

- 2) Check braking system for correct pressure and the brake pedals for permissible play.
- 3) Check the main gear shock struts for loss of oil. If so, add Spindle oil-Green in accordance with the appropriate instructions. The pressure within

the unloaded shock struts must be:

Main gear	25 atu	(365 psi)
Tail strut	31 atu	(455 psi)

Check for a secure fit of the shock strut leather sleeves as they protect the sliding surfaces of the struts from sand, dirt and dust.

- 4) Carry out a daily check of the sealed air-jack pressure. Specified: 95 atu (1400 psi).



**D. (Luft) T. 2190 A-8**

**For Official Use Only!**

# **Fw 190 A-8**

**Aircraft Handbook**

**Part 3**

**Control unit assembly**

**(Effective July 1944)**

**Issued September 1944**



## Description

### A. General

The control unit assembly consists of the horizontal stabilizer and elevators (1,1), the vertical stabilizer and rudder (1,2), the ailerons (1,3), and the landing flaps (1,4). The control surfaces have no servo trims, only ground adjustable tabs. The horizontal stabilizer can, however, be electrically adjusted, in flight, for changes of trim.

All control surfaces have mass balancing, and are, except for their leading edges, fabric covered.

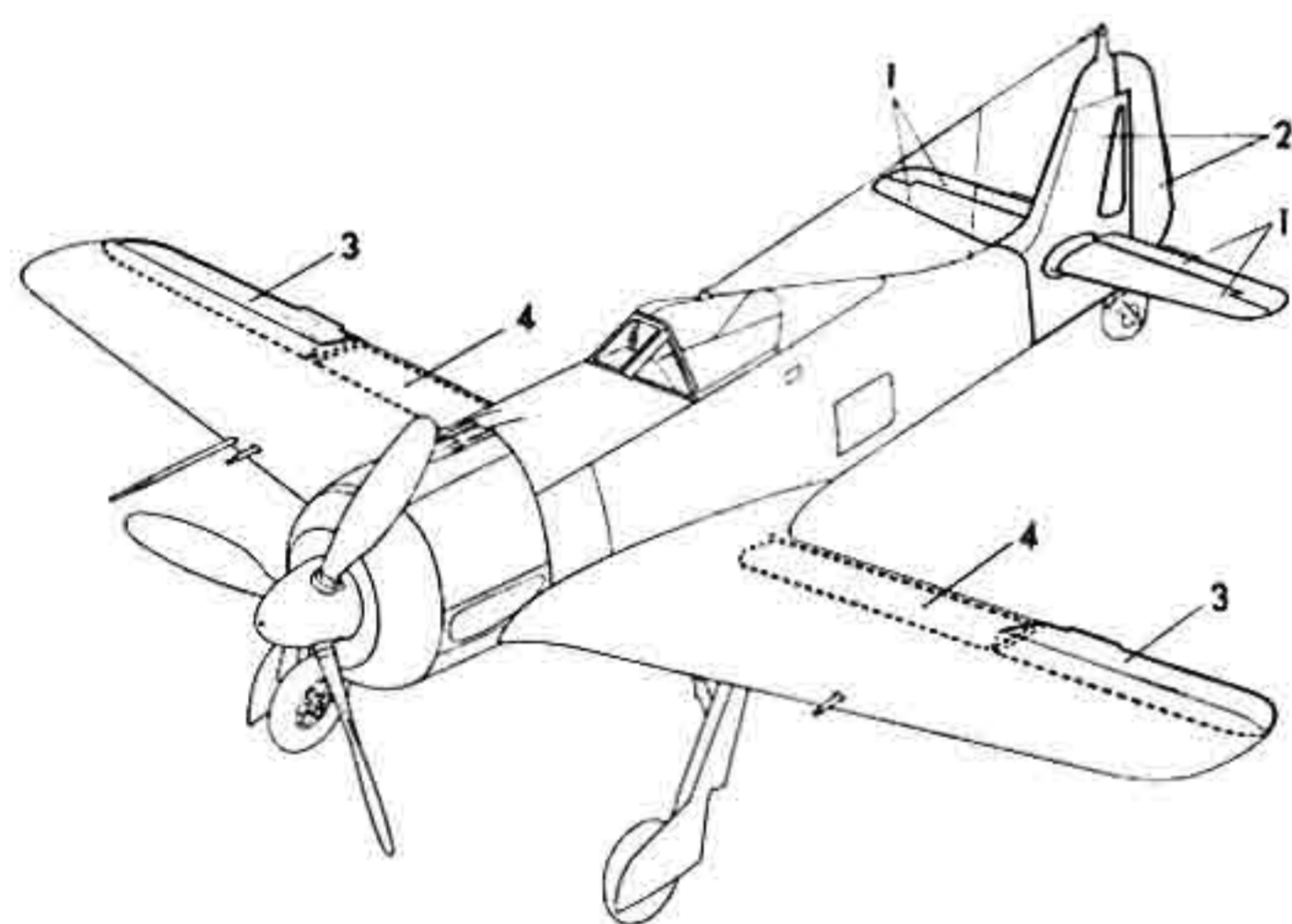

1 Elevator unit  
2 Rudder unit  
3 Ailerons  
4 Landing flaps

Fig. 1\*: Control unit assembly

See Part 4 concerning actuation of the control surfaces and the landing flaps.

### B. Elevator unit

The elevator unit has a symmetrical airfoil, has rounded ends, and is of trapezoidal shape. Its leading edge is on the fuselage longitudinal axis while its rotational axis is positioned 11,5 mm (0.45 in) above it. It consists of a one-piece horizontal stabilizer (2,1) and two elevator halves (2,2).

The horizontal stabilizer (3,1) is of Aluminum construction with a one-piece spar. Basically, it consists of an upper and lower shell, riveted

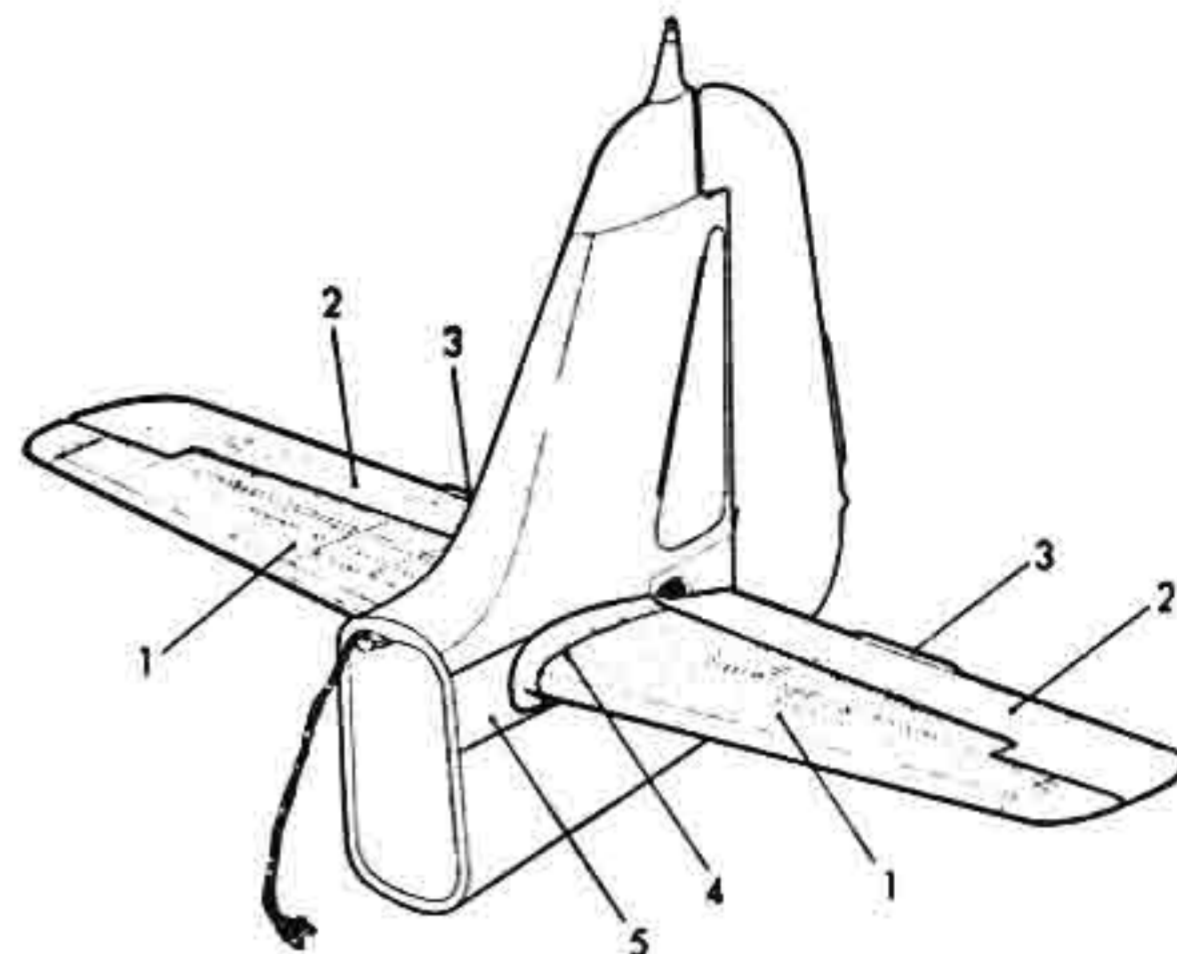

1 Horizontal stabilizer  
2 Elevator half  
3 Trim tab  
4 Stabilizer fairing panel  
5 Cover plate

Fig. 2: Elevator unit

together, to which are screwed the leading edges (3,2) and the tips (3,3).

The stabilizer is attached to both sides of the diagonal spar by a pivotal mounting. Its leading edge upper attachment point connects to an electric motor through a drive spindle; thus permitting stabilizer adjustment. Vertical stresses are passed through the drive spindle to the vertical stabilizer (see Fig. 7).

Sideways movement of the stabilizer is prevented by a triangular stress frame (7,3) which is connected to the leading edge lower attachment point and to the tail unit forward bulkhead.

#### 1. Horizontal stabilizer

The horizontal stabilizer is actuated by a spring-

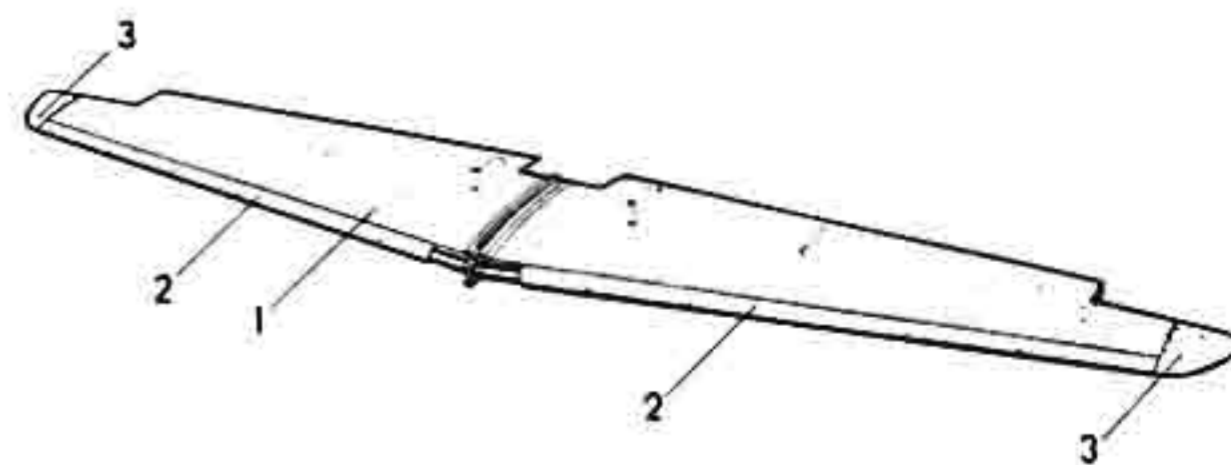

1 Horizontal stabilizer  
2 Leading edges  
3 Tips

Fig. 3: Horizontal stabilizer

loaded switch located on the cockpit left instrument console, and can be moved between  $+4^\circ$  and  $-1^\circ$  (see Part 9A under III., 6. 'Horizontal stabilizer - incidence indicator' and Part 4 'Flight Controls').

## 2. Elevator

The elevator comprises two interchangeable half units, each of which is attached to the stabilizer by three pivot bearings (4,1). The elevator halves are joined at their spars and leading edges (4,2). The elevator actuation lever is positioned between the two flanges (see Fig. 7).

Each elevator half unit consists of two frame panels, a spar (to which the leading edge is riveted), and attached ribs. It is fabric covered.

The elevator is both aerodynamically and mass balanced; in addition, it has ground adjustable trim tabs (4,4).

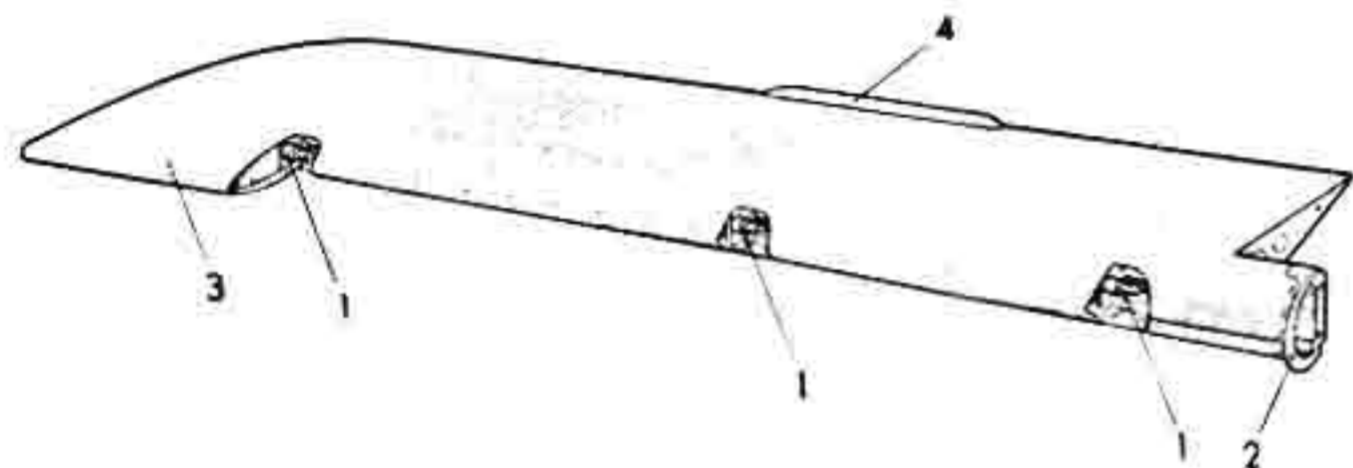

- |                     |                |
|---------------------|----------------|
| 1 Pivot bearings    | 3 Balance horn |
| 2 Connecting flange | 4 Trim tab     |

Fig. 4: Elevator half unit

## C. Rudder unit

The centrally mounted rudder unit consists of the vertical stabilizer (5,1) and rudder (5,2).

### 1. Vertical stabilizer

The vertical stabilizer and tail unit comprise a single unit which screws onto the fuselage rear section (attachment bulkhead) (5,3). The vertical stabilizer consists primarily of left (6,1 and 2), and right (6,3 and 4), panels and a diagonal spar (6,5). The panels are stiffened by ribs; and capped by a formed leading edge (6,13), and a rounded tip (6,11).

The diagonal spar (6,5) carries the forged fittings for the tailwheel drag yoke (6,17), the horizontal stabilizer (6,16), and the tailwheel retraction cable pulleys (6,14). In addition, the tailwheel shock strut guide (6,15) is attached to it. Within the vertical stabilizer are also positioned: the

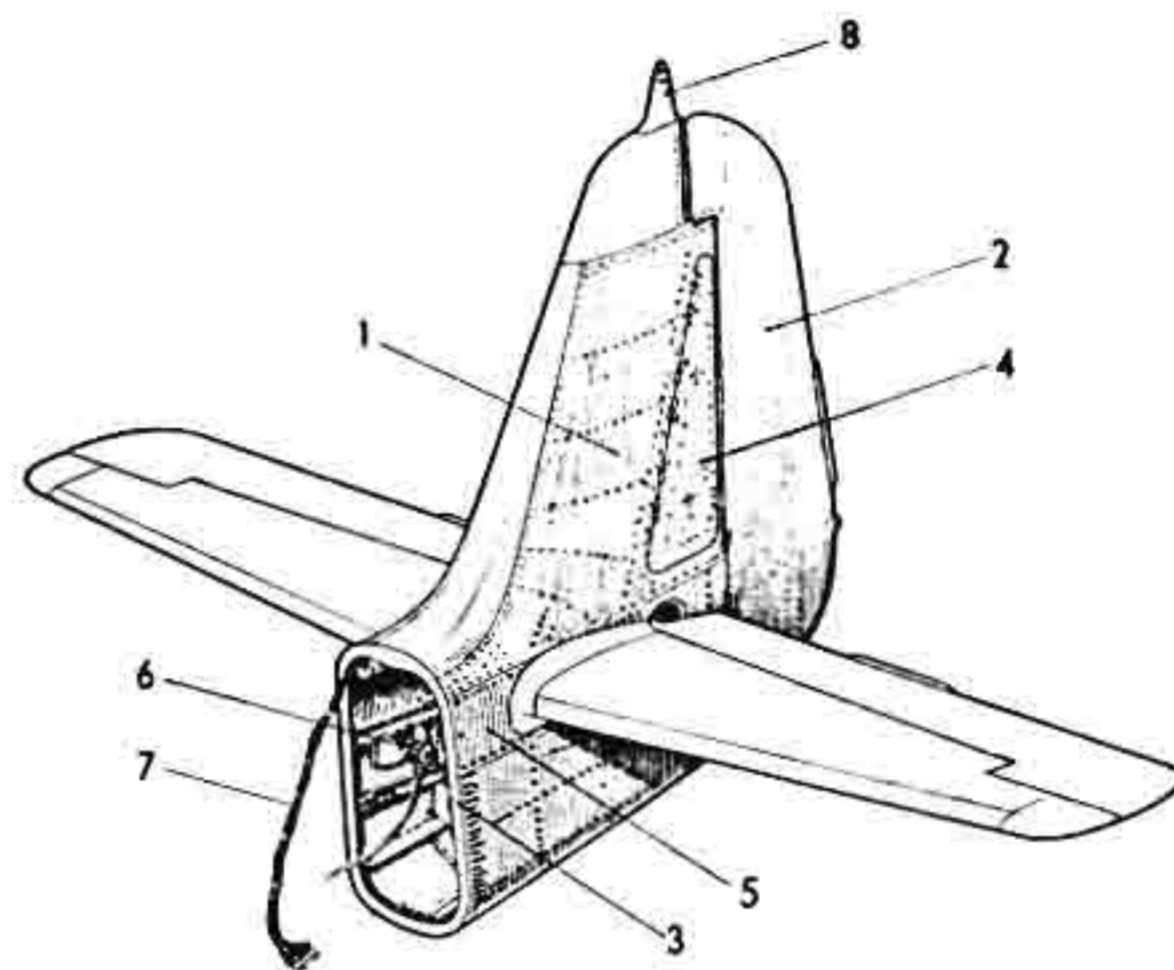

- |                              |   |
|------------------------------|---|
| 1 Vertical stabilizer        | 6 Horizontal stabilizer incidence transmission unit         |
| 2 Rudder                     | 7 Electrical leads for tail light and stabilizer trim motor |
| 3 Tail unit attachment frame | 8 Antenna attachment horn                                   |
| 4 Inspection door            |   |
| 5 Cover plate                |   |

Fig. 5: Rudder unit

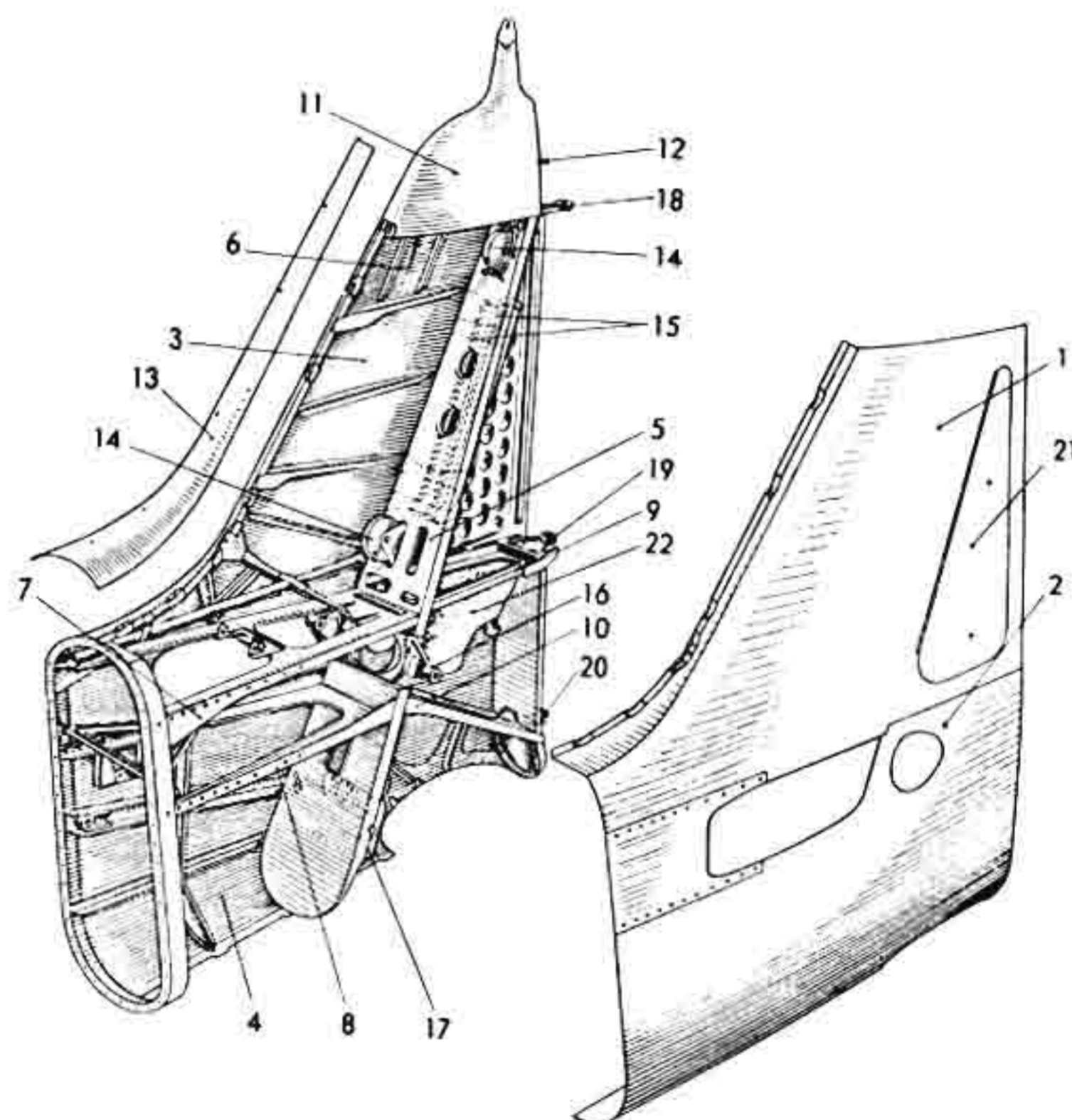

- |                      |  |
|----------------------|--|
| 1 Upper panel, left  | 12 Tip spar                                  |
| 2 Lower panel, left  | 13 Leading edge                              |
| 3 Upper panel, right | 14 Retraction cable pulley                   |
| 4 Lower panel, right | 15 Retraction cable guide tube               |
| 5 Diagonal spar      | 16 Horizontal stabilizer rear mounting point |
| 6 Rib 8              | 17 Tailwheel drag yoke attachment bracket    |
| 7 Rib 9              | 18 Rudder top attachment frame               |
| 8 Rib 10             | 19 Rudder middle attachment frame            |
| 9 Rib 11             | 20 Rudder bottom attachment frame            |
| 10 Rib 12            | 21 Inspection door                           |
| 11 Rounded tip       | 22 Fabric cuff                               |

Fig. 6: Vertical stabilizer construction (left panels removed)

elevator differential bellcrank (7,12), the horizontal stabilizer trim motor (7,10), the tailwheel unit, and the three rudder attachment fittings (6, 18-20). A large inspection door (6,21) in the left upper panel permits servicing of the tailwheel unit.

The horizontal stabilizer passes through the tail unit. To protect the inside of the tail against dirt, a fabric cuff (6,22) is fastened to Rib 11 (6,9), and secured to the tailwheel shock strut by an elastic band. The tailwheel extension spring passes through the cuff; this spring attaches to the tailwheel down-lock and to a fitting on Rib 12 (6,10). At its forward end, the fabric cuff is secured by snap fasteners.

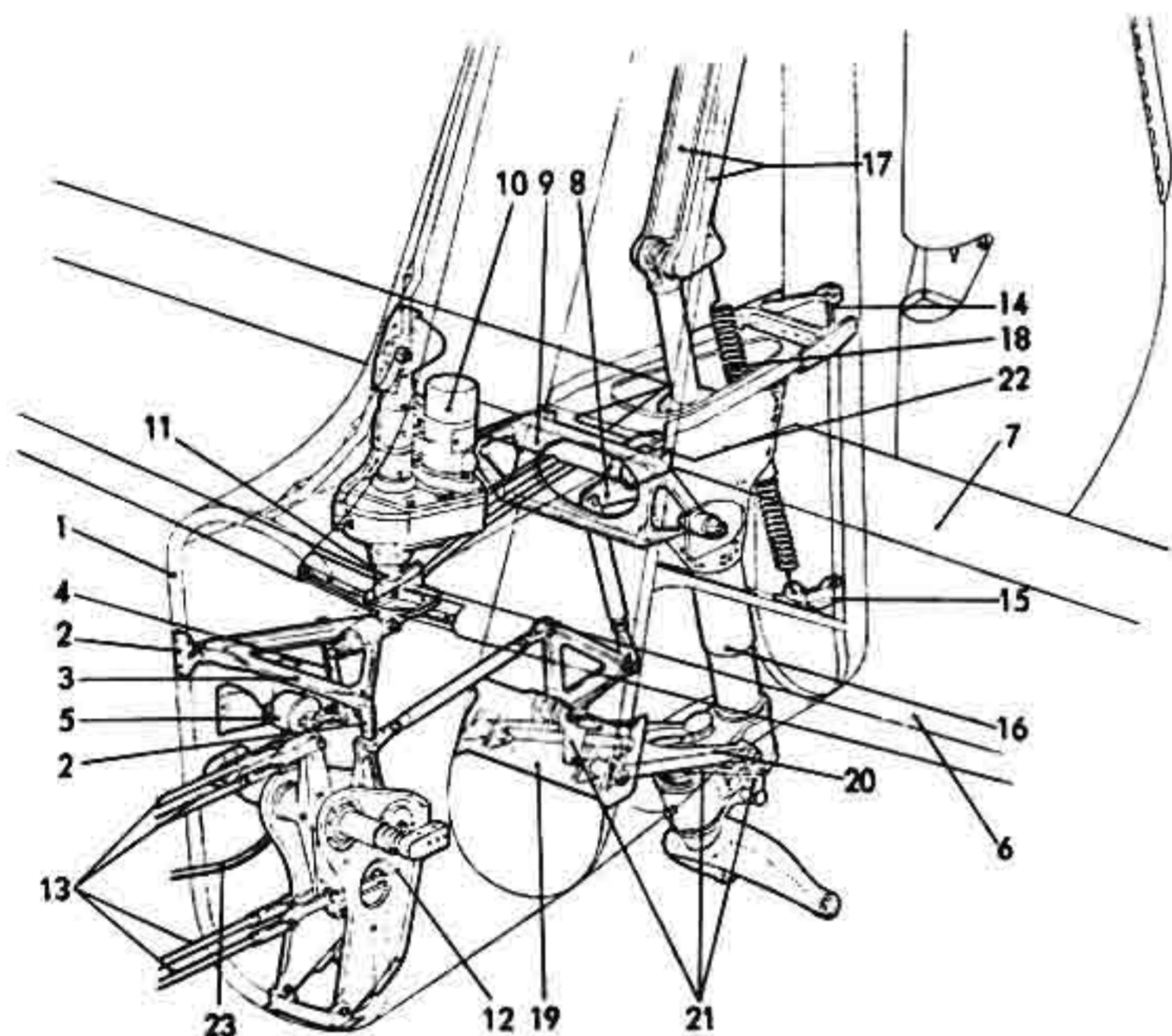

- |  |   |
|--|---|
| 1 Tail unit attachment frame               | 12 Elevator differential bellcrank                      |
| 2 Mounting lug                             | 13 Control cables                                       |
| 3 Triangular stress frame                  | 14-15 Rudder attachment fittings                        |
| 4 Linkage rod                              | 16 Tailwheel shock strut                                |
| 5 Stabilizer incidence relay unit          | 17 Shock strut guide                                    |
| 6 Horizontal stabilizer                    | 18 Extension spring                                     |
| 7 Elevator                                 | 19 Drag yoke mounting bracket                           |
| 8 Elevator actuation lever                 | 20 Drag yoke  |
| 9 Horizontal stabilizer attachment fitting | 21 Tailwheel locking linkage                            |
| 10 Horizontal stabilizer trim motor        | 22 Fabric cuff  |
| 11 Drive spindle                           | 23 Electrical leads for stabilizer incidence indication |

Fig. 7: Tail unit/vertical stabilizer components

## 2. Rudder

The rudder is constructed, in a manner similar to the elevators, of the following components: 2 frame panels, 1 spar, and 7 ribs—it is fabric covered. It has aerodynamic horn balancing (8,1), mass balancing and a ground adjustable trim tab (8,2).

The rudder is attached to the vertical stabilizer by

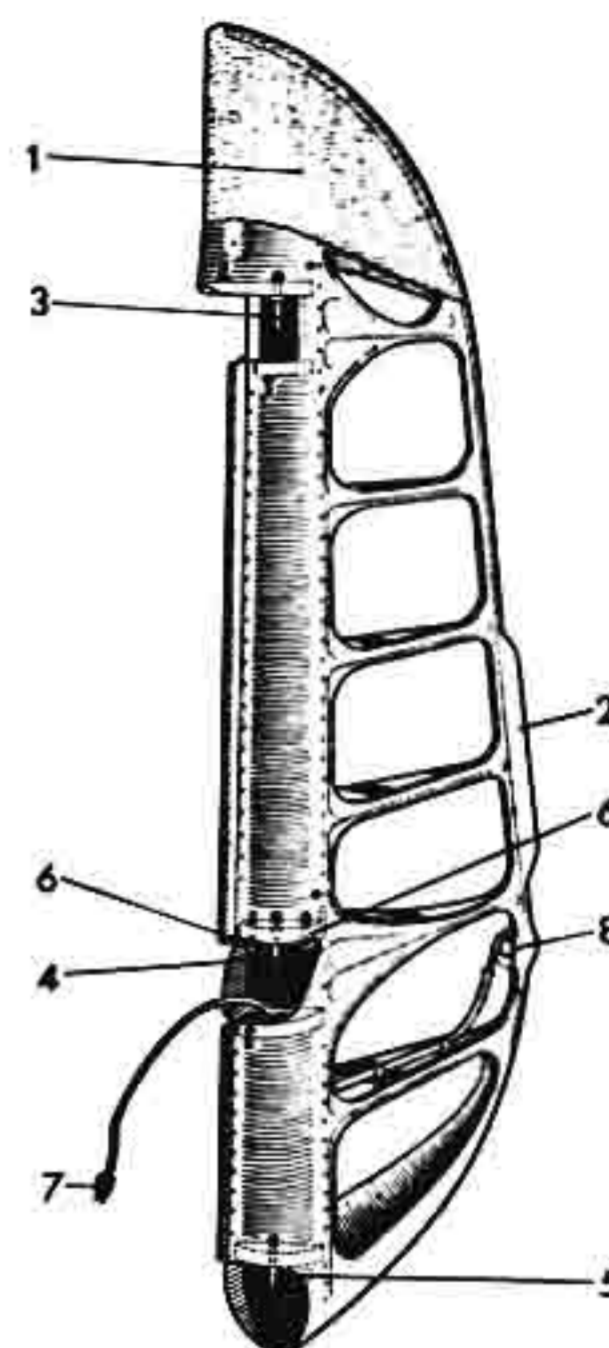

- |                        |   |
|------------------------|---|
| 1 Balance horn         | 5 Lower pivot bearing                         |
| 2 Trim tab             | 6 Attachment bolts for rudder actuation lever |
| 3 Upper pivot bearing  | 7 Electrical lead for tail light              |
| 4 Centre pivot bearing | 8 Tail light                                  |

Fig. 8\*: Rudder

three pivot bearings (8,3-5), and is positioned by an actuation lever bolted to the centre attachment point (see also Fig. 6).

## D. Ailerons

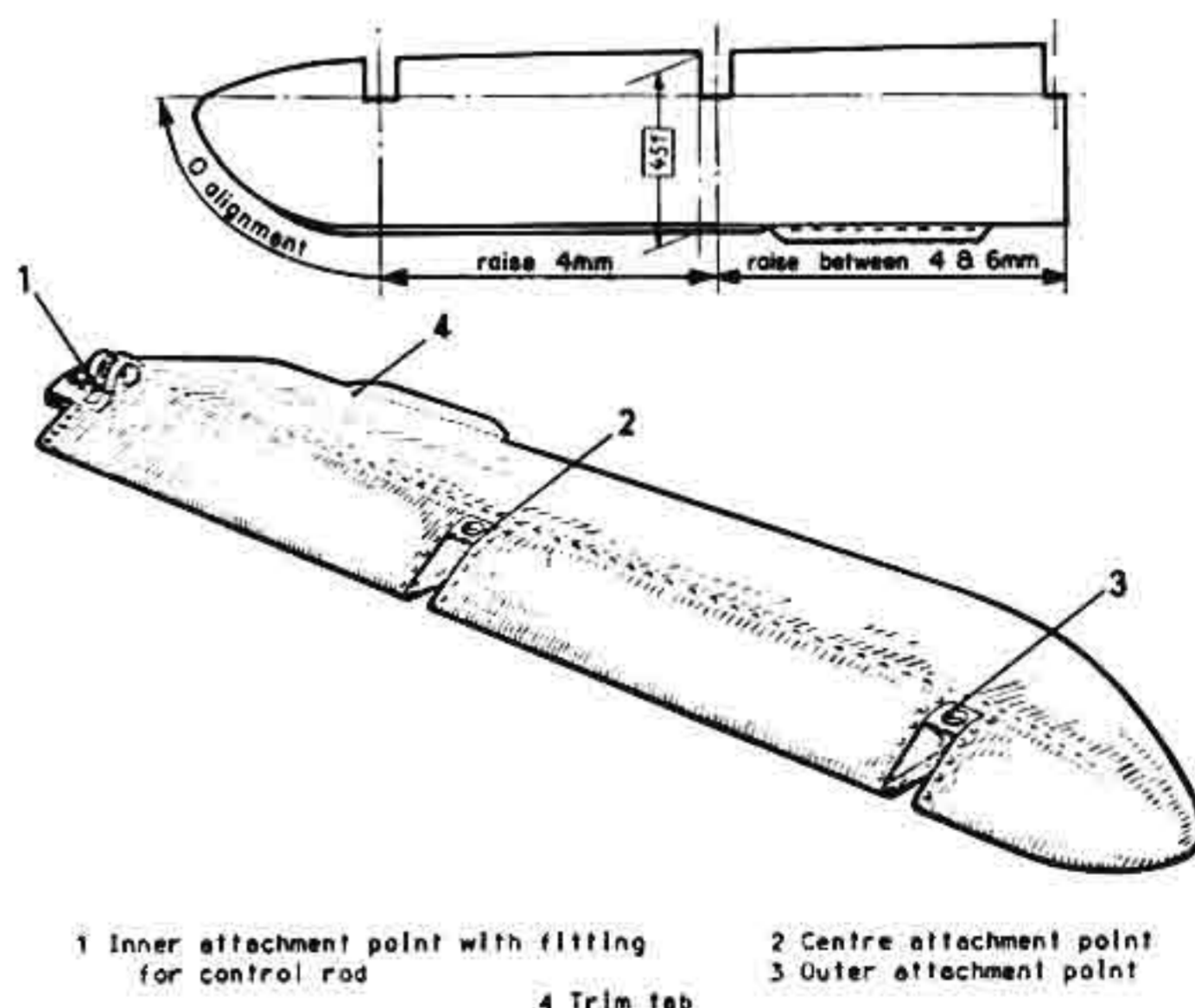

- |   |                           |
|---|---------------------------|
| 1 Inner attachment point with fitting for control rod | 2 Centre attachment point |
|   | 3 Outer attachment point  |
|   | 4 Trim tab                |

Fig. 9: Aileron

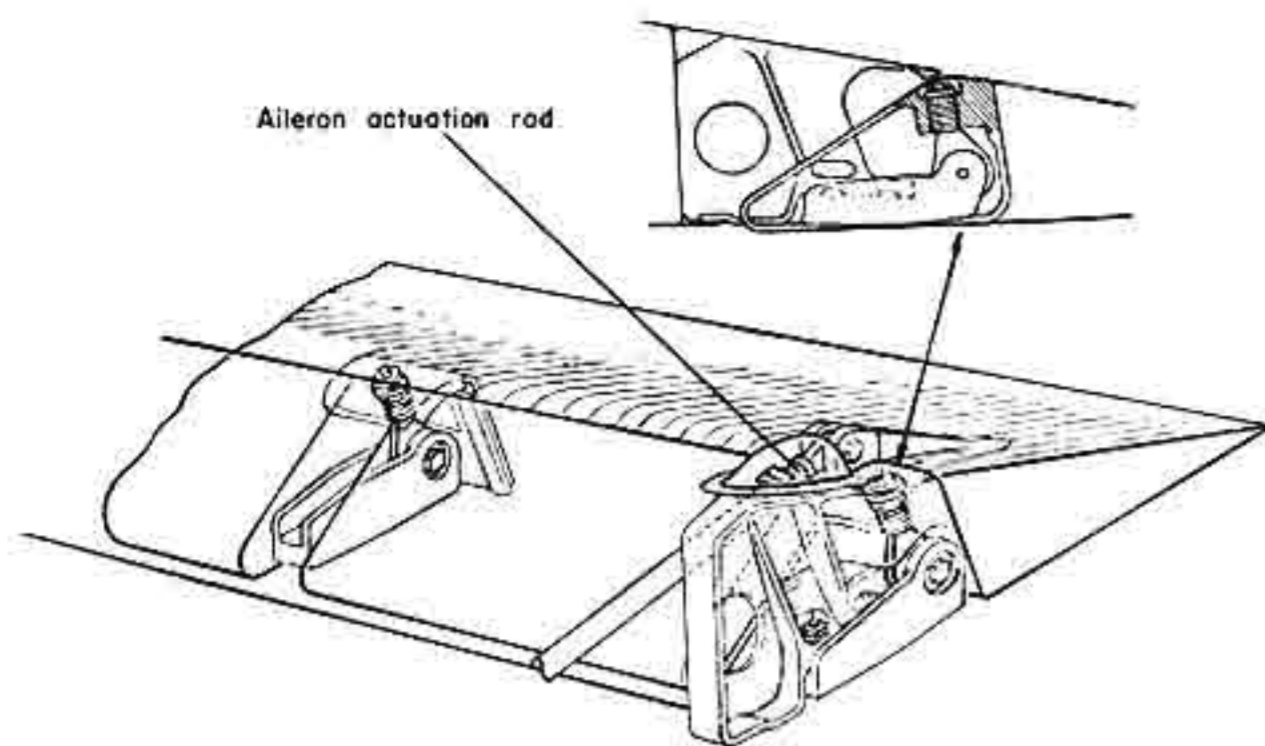
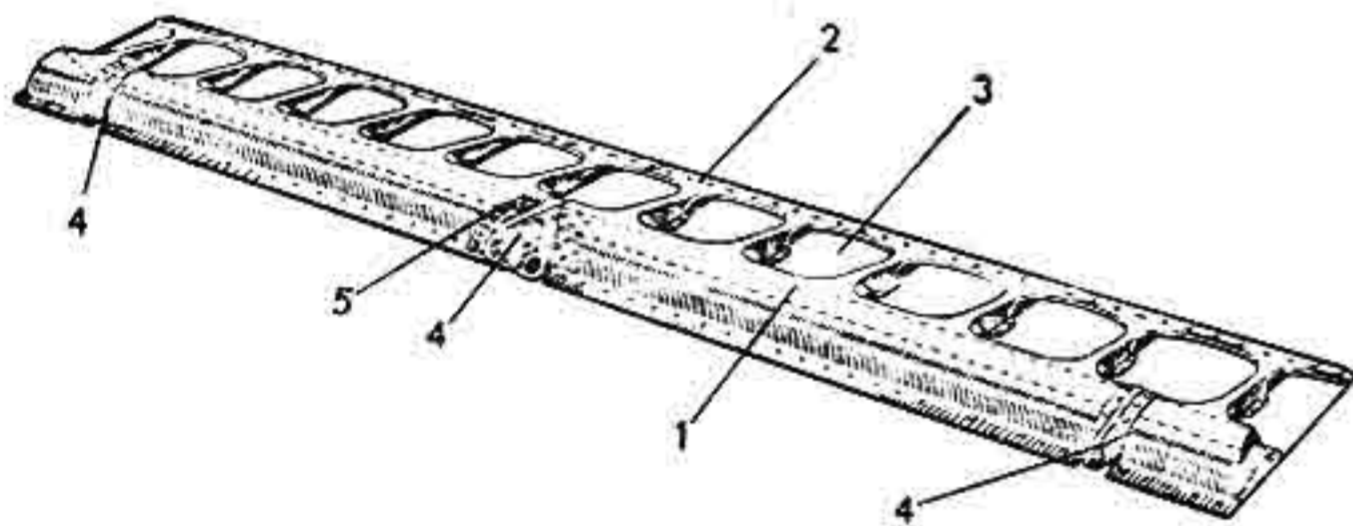

Fig. 9a: Aileron skematic

The ailerons are constructed in the same manner as the other control surfaces; with mass balancing, trim tabs and fabric covering (Fig. 9 and 9a).

## E. Landing flaps

The landing flaps are of split-type design and are interchangeable.



1 Spar  
2 Upper frame panel  
3 Lower frame panel  
4 Wing attachment fittings  
5 Flap position scale

Fig. 10: Landing flap

They consist of a spar (10,1) and two frame panels (10,2 and 3). The lower surface is metal covered, the upper surface is open.

The landing flap is attached to the wing at three points.

They are actuated electrically; the actuating arm is attached to the centre attachment point which has been reinforced.

The flaps can be set to three positions: flight, take-off, and landing. Retraction and extension are controlled by push-buttons on the left instrument console. The flap position indicator lights are contained in the undercarriage/landing flap indicator unit.

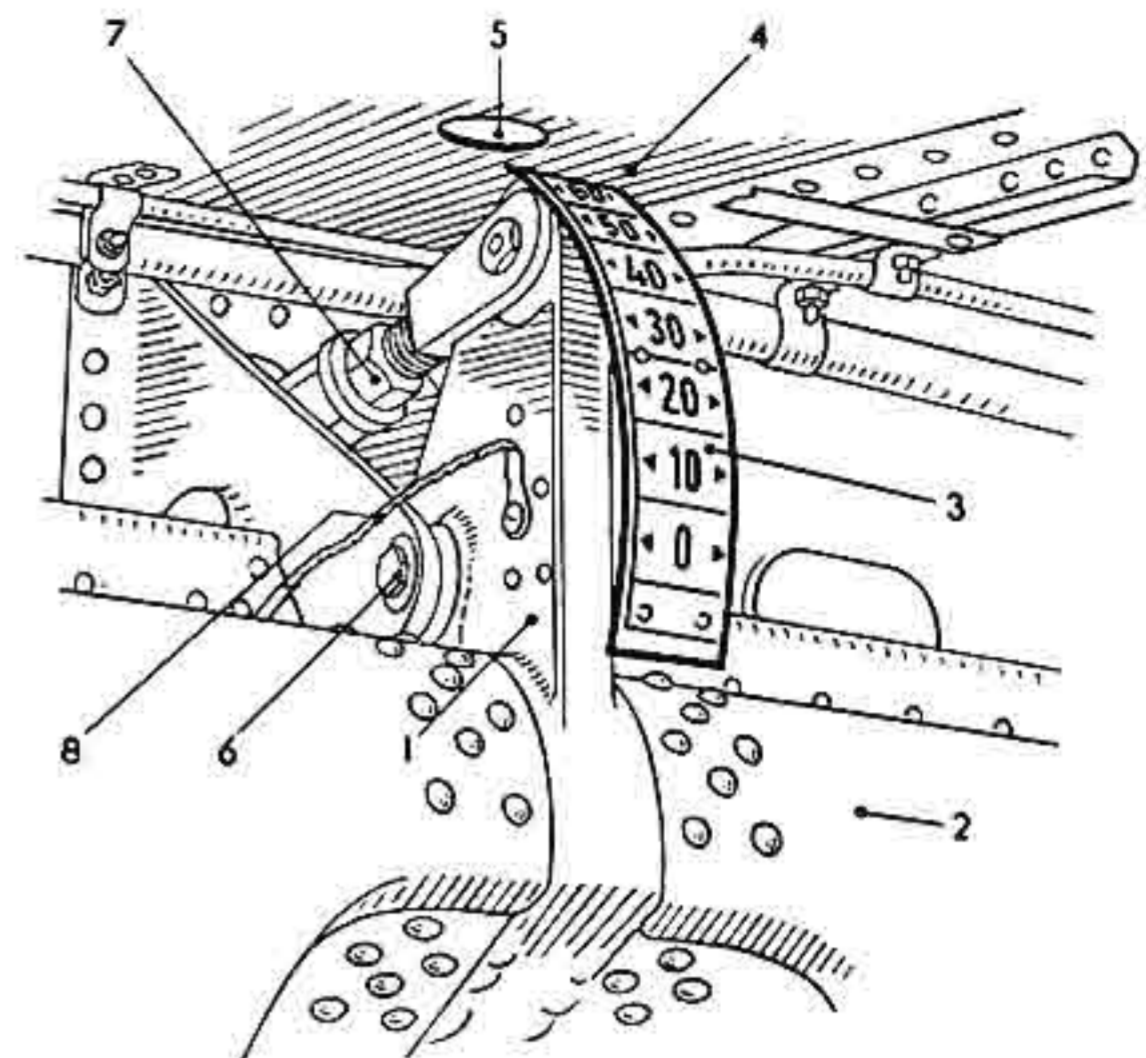

1 Flap centre attachment fitting  
2 Landing flap  
3 Semi-circular graduated scale  
4 Wing covering  
5 Viewing hole  
6 Wing/flap attachment point  
7 Actuation rod  
8 Grounding wire

Fig. 11: Landing flap mechanical position indicator

They also have mechanical position indication; this consists of a graduated semi-circular scale (11,3) mounted on the flap actuating arm (11,1). There is a circular hole (11,5) in the upper skin of both wing halves to permit viewing of this scale from the cockpit.

## F. Control locks

There are clamps available with which to lock the control surfaces. These surfaces can also be locked by connecting the control stick (12,1) and the left rudder pedal arm (12,2) by a cord with a snap fastener at one end, and a buckled strap at the other.

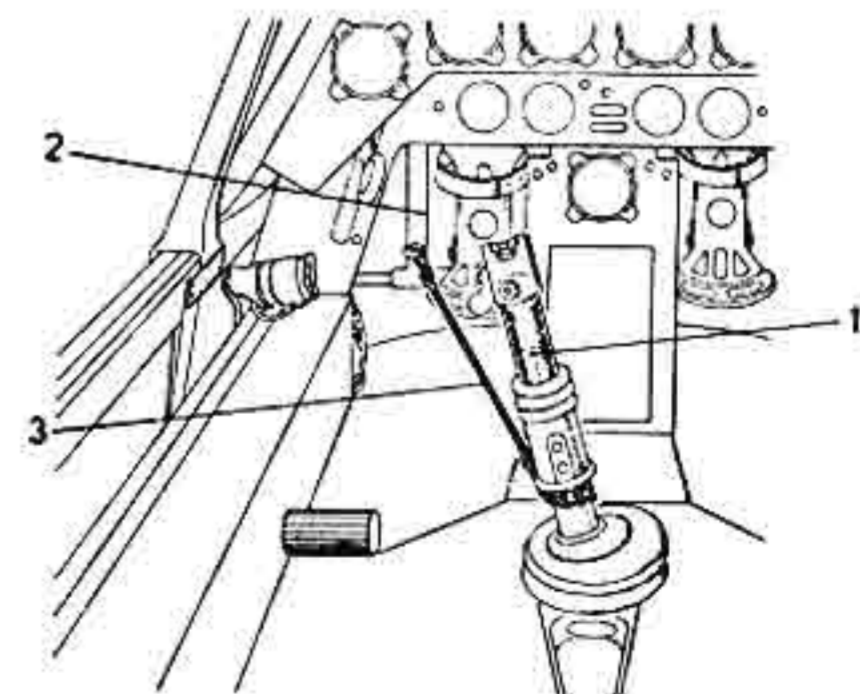

1 Control stick  
2 Rudder pedal arm  
3 Locking cord

Fig. 12: Control surfaces locking cord attachment



D. (Luft) T. 2190 A-8

For Official Use Only!

# **Fw 190 A-8**

Aircraft Handbook

**Part 4**

**Flight controls**

**(Effective July 1944)**

**Issued September 1944**

## Description

### A. General

The flight controls consist of the elevator, rudder, and aileron control surfaces; and the flap and stabilizer actuation mechanisms.

The three sets of control surfaces have no inflight trim capability, possessing only ground adjustable trim tabs. The stabilizer and landing flaps are actuated electrically.

Transmission of steering movements to the control surfaces is via a system of push-rods, DUZ-flexible push-rods, and control cables.

The control train to both the rudder and elevators contains differential bellcranks which keep control stick, or rudder pedal, forces to a minimum near the control surface neutral positions. About these neutral positions, a large movement of the control stick, or rudder pedals, will result in only a small control surface movement. This difference decreases as control surface deflection increases.

Note: In later production series aircraft, the differential bellcrank for the rudder is replaced by non-differential bellcranks.

Elevator deflection is limited by mechanical stops in the control stick mounting base.

The elevator control train is shown in Fig. 2.

The construction of the differential unit is illustrated in Fig. 3.

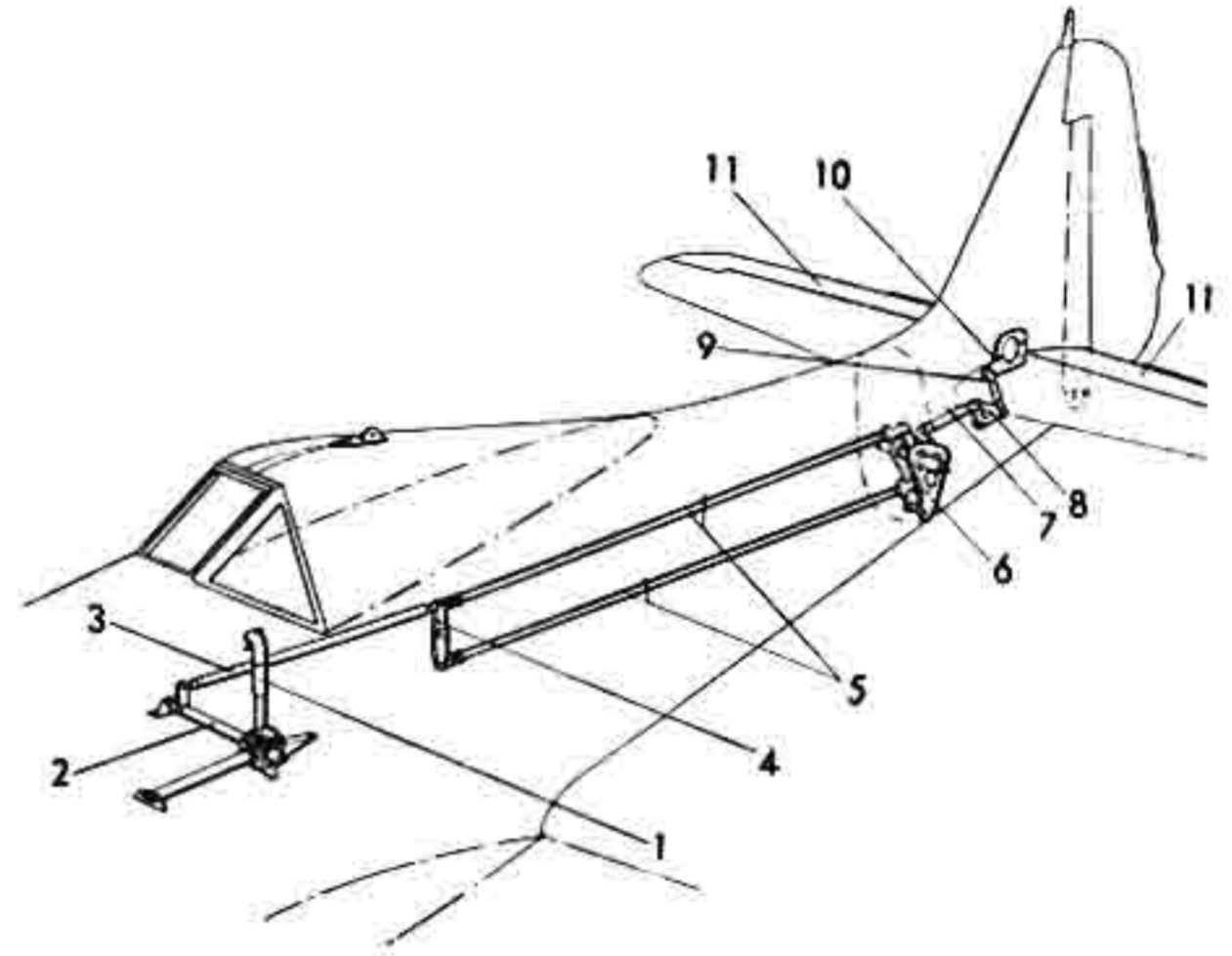

1 Control stick	6 Elevator differential unit
2 Elevator control torsion bar	7 Push-rod
3 Push-rod	8 Bellcrank
4 Bellcrank (Bulkhead B)	9 Push-rod
5 Control cables	10 Elevator actuation lever
	11 Elevator

### B. Elevator controls

The control stick is in the neutral position at a point  $1^{\circ}30'$  forward of vertical (Fig. 1). Control stick movement is  $20^{\circ}30'$  forward, and  $21^{\circ}30'$  rearward.

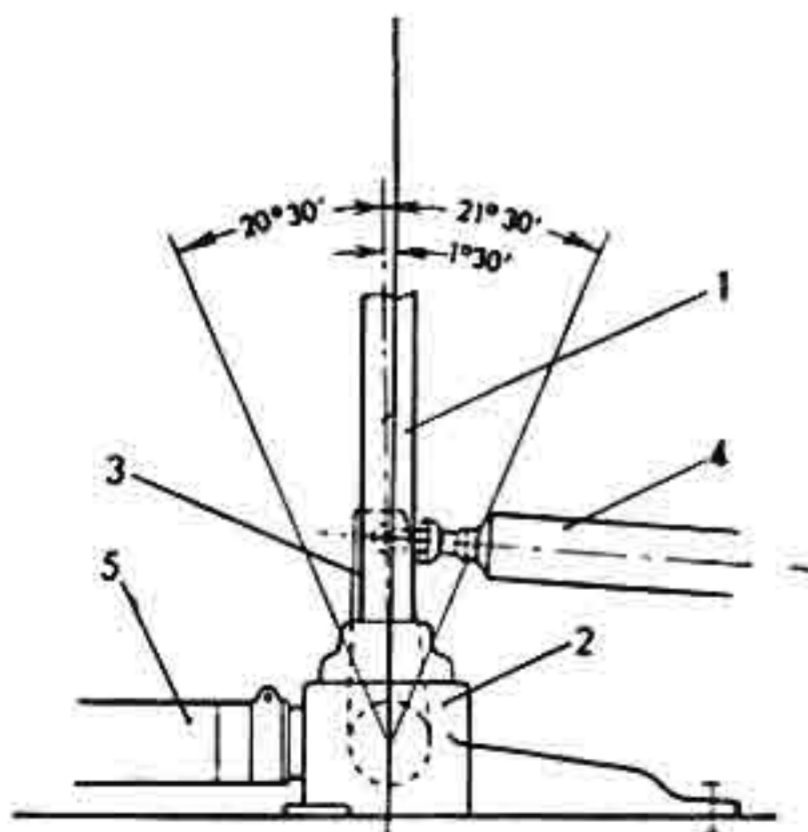

1 Control stick	3 Elevator actuation lever
2 Control stick mounting base	4 Push-rod
5 Aileron control torsion bar	

Fig. 1: Control stick movement

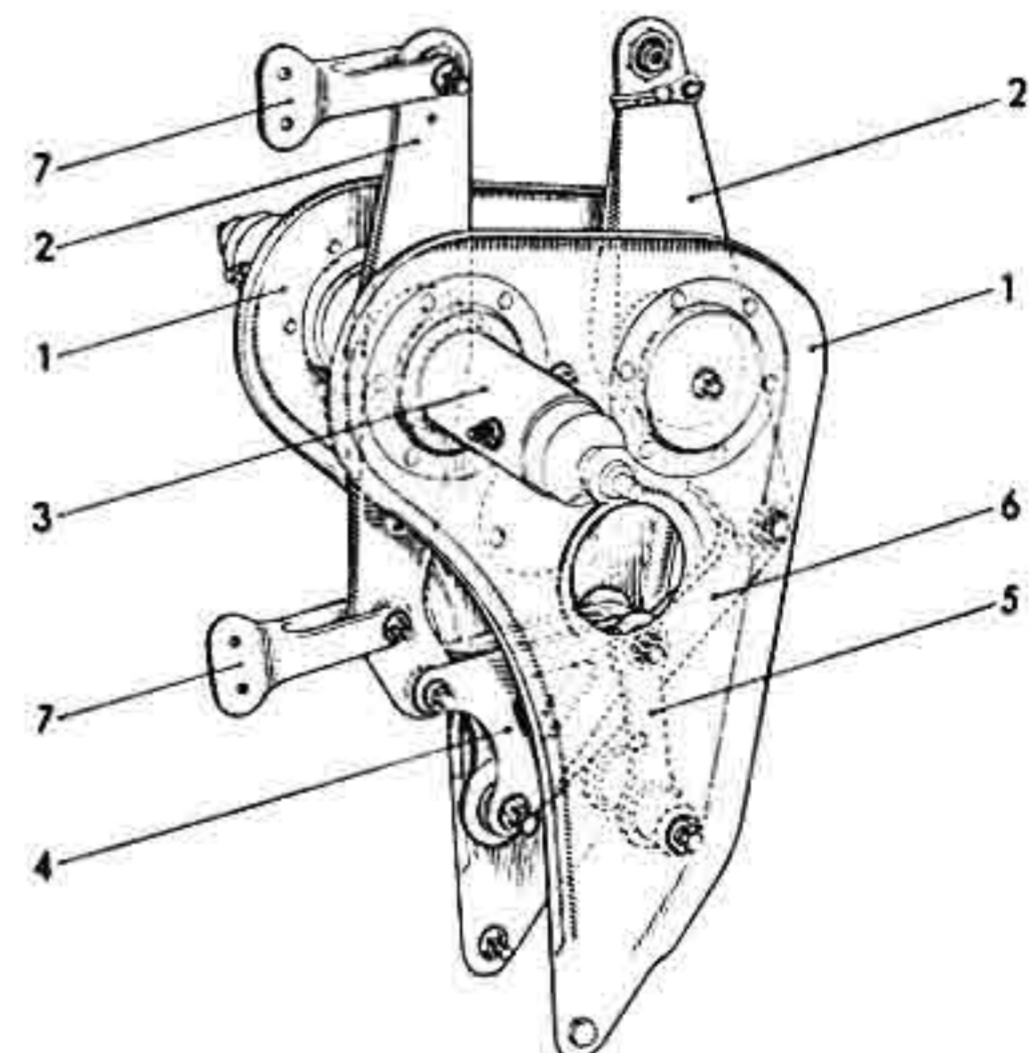

1 Side plate	4 Differential crank
2 Lever	5 Radius rods
3 Torsion bar	6 Actuation strut
7 Control cable attachment fittings	

Fig. 3: Elevator differential unit

### C. Rudder controls

The rudder control train is as shown in Fig. 4.

The position of the rudder pedals can be adjusted to suit the individual pilot, by rotation of the adjustment grips (4,8) to vary the length of the adjustable push-rods (4,3). The adjustment forward and aft is 55 mm, for a total of 110 mm (4.3 in). These grips are within the reach of the seated pilot and can be moved simultaneously.

Rudder deflection is limited by stops within the differential unit.

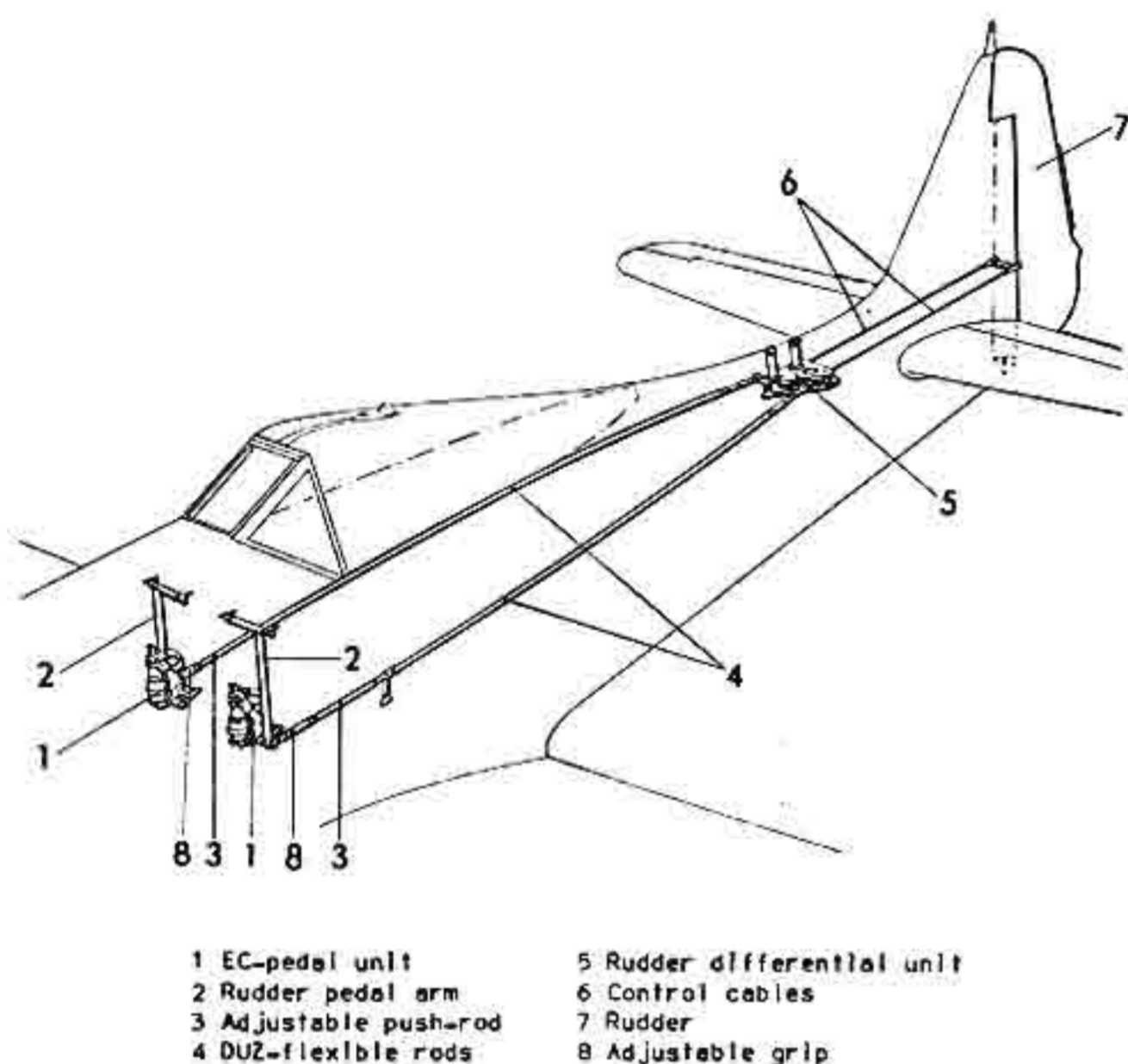

Fig. 4: Rudder controls

### D. Aileron controls

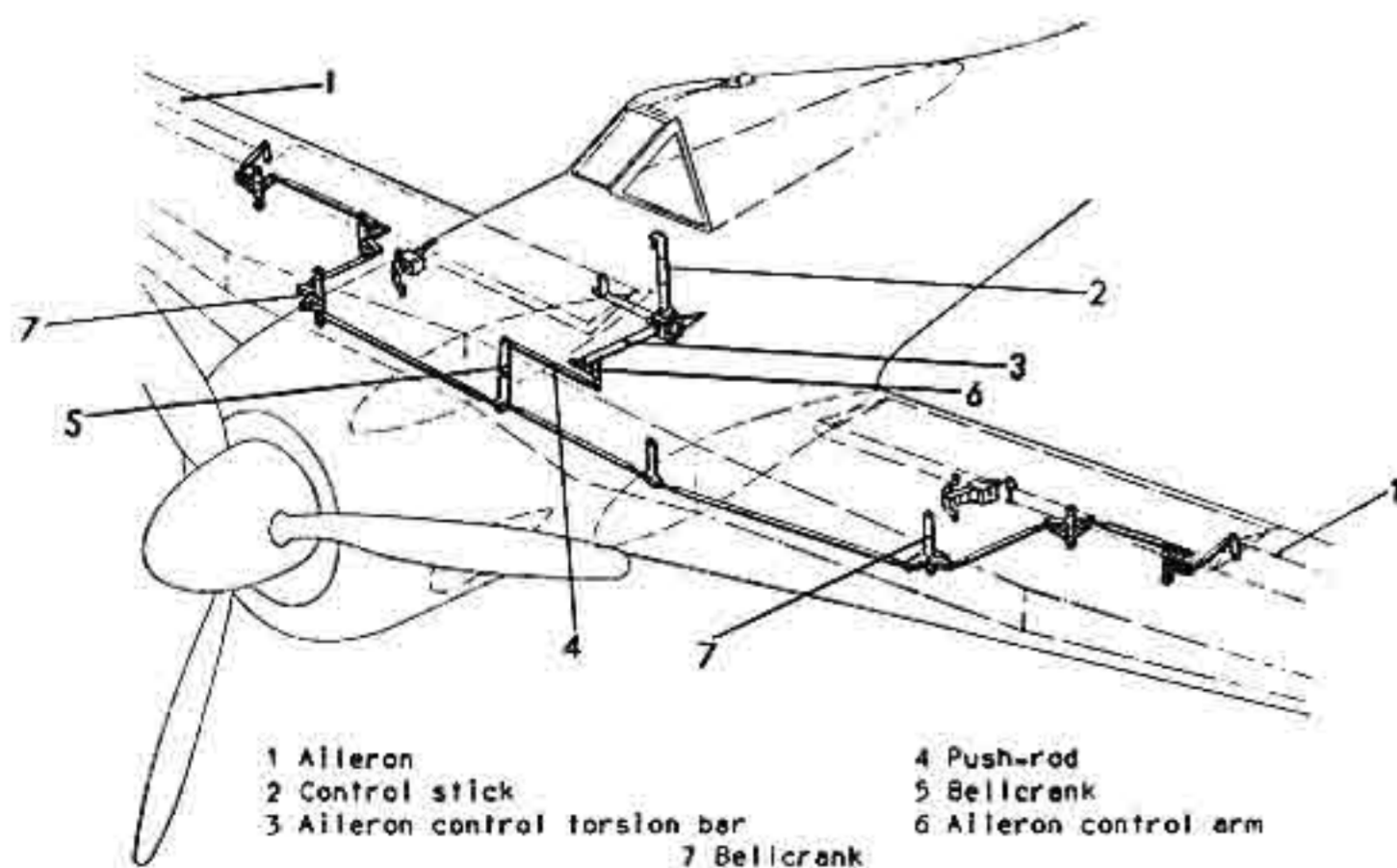

Fig. 5: Aileron controls

The ailerons (5,1) are moved by the sideways motion of the control stick (5,2). The transmission of control forces is as shown in Fig. 5.

A hole in the cockpit floor through which the aileron control arm (5,2) passes is protected by a dust cover.

Aileron deflection is limited by mechanical stops in the control stick mounting base.

### E. Flap and stabilizer controls

#### 1. Landing flap controls

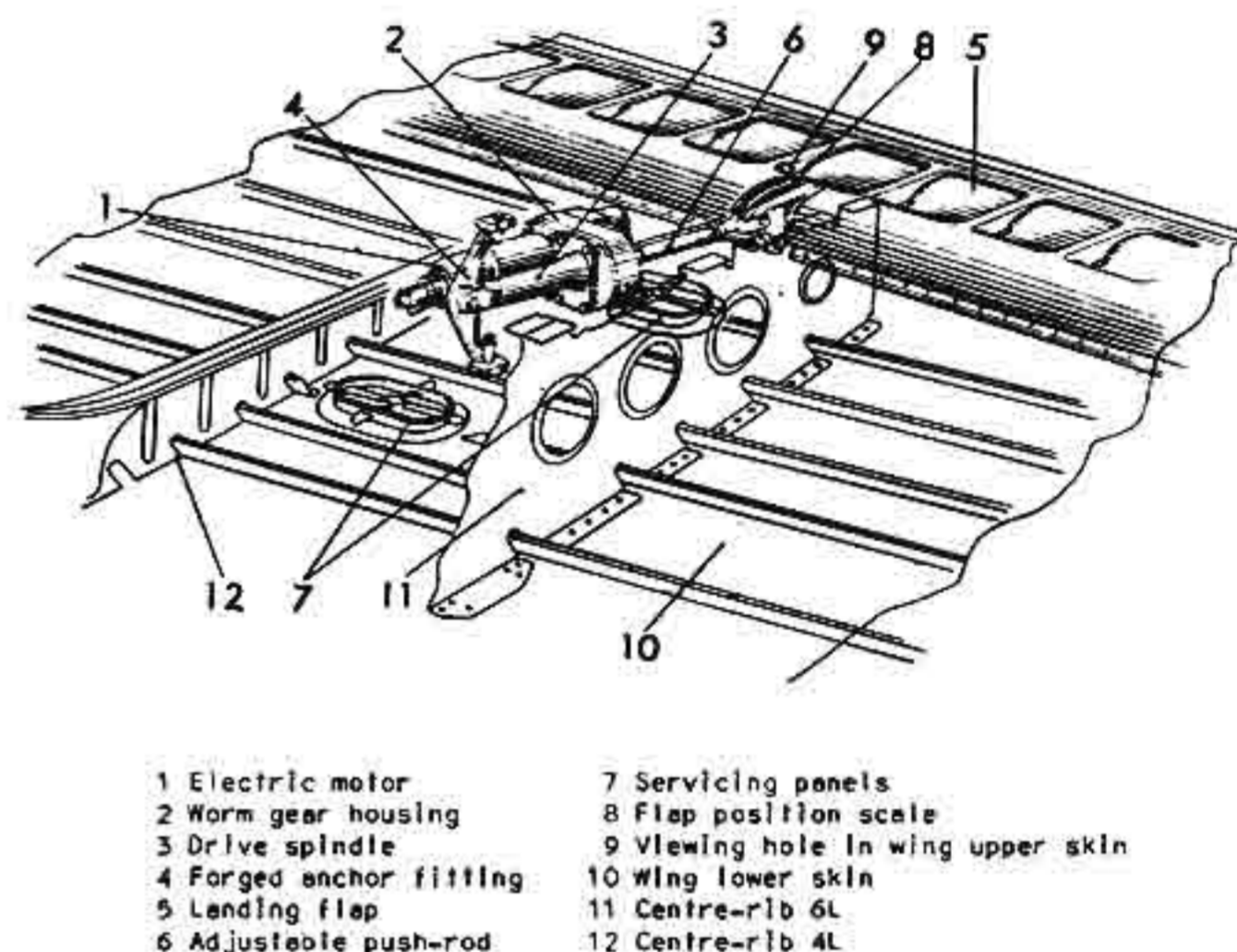

Fig. 6: Landing flap system

The flaps are positioned electrically, the drive motor push-rod being attached to the flap central attachment fitting. The two motors are synchronized to ensure equal flap movement.

Each flap drive system consists of an electric motor (6,1), a worm gear housing (6,2), and a drive spindle (6,3); all contained within a single unit which is attached to the wing by a pivoting forged anchor fitting (6,4). An adjustable push-rod (6,6) connects the motor to the flap (6,5). The anchor fitting and adjustable push-rod are accessible through servicing panels (6,7) in the wing lower skin (6,10).

The flap actuation buttons are located on the left instrument console (7,1). An individual push-button is provided for each of the three flap positions (Out, Take-off, In). The flap drive motors are actuated when one of these buttons is depressed; they are automatically switched off when the designated flap position is reached. A push-button will remain down until another flap selection is made, at which time it will pop back up.

Flap position is indicated electrically by the middle two bulbs (7,5) in the 6-bulb indicator unit (7,6). The bulb colours are: red-'In' and green-'Out'; there is no electrical monitoring of the 'Take-off' setting.

There is also mechanical flap indication, see Part 3 Fig. 11.

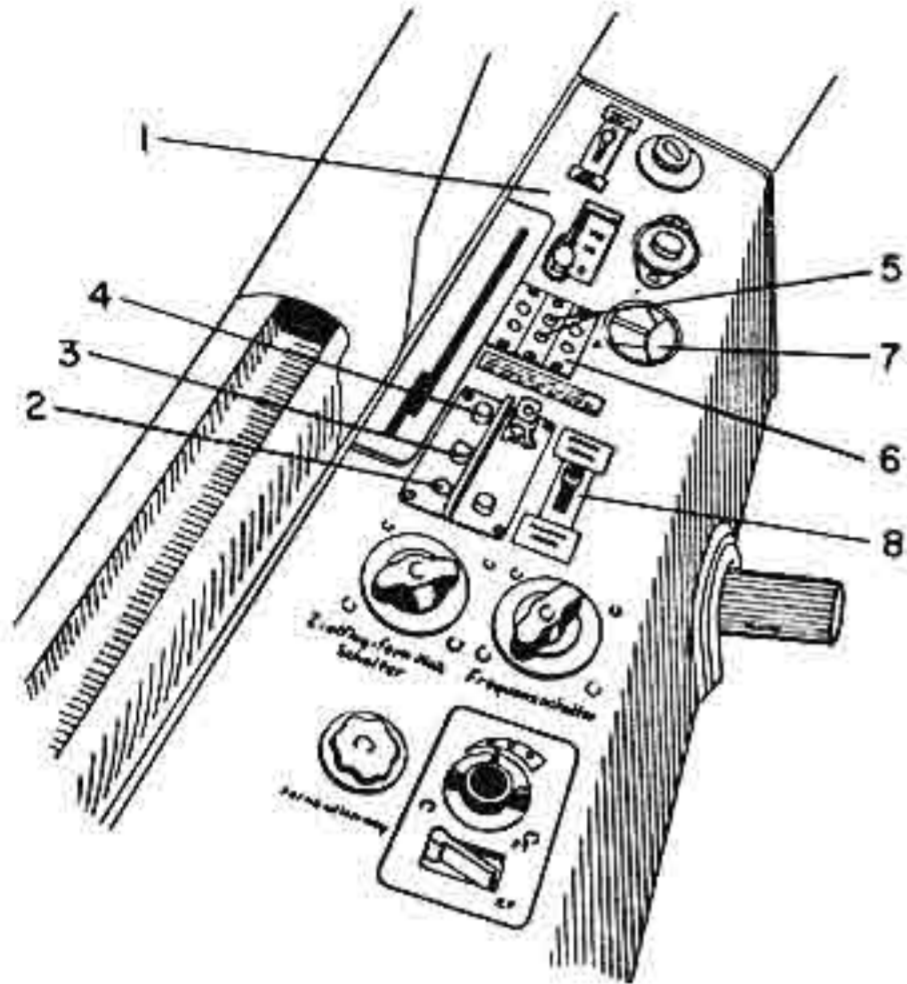

- |                              |                                  |
|------------------------------|----------------------------------|
| 1 Left instrument console    | 5 Position indicator lights      |
| 2 Push-button for 'Out'      | 6 6-bulb indicator unit          |
| 3 Push-button for 'Take-off' | 7 Stabilizer incidence indicator |
| 4 Push-button for 'In'       | 8 Stabilizer trim switch         |

Fig. 7: Flap and stabilizer controls

## 2. Horizontal stabilizer adjustment

The stabilizer incidence can be altered to compensate for changes in aircraft trim. Actuation is through an electric motor (8,1) with attached worm-gear housing (8,2) and drive spindle (8,3).

The motor is mounted within the vertical stabilizer (8,4) and is attached to the leading edge upper attachment point (8,5) by the drive spindle (8,3).

The stabilizer can be rotated through  $5^\circ$ , from  $+4^\circ$  relative to the fuselage longitudinal axis, to  $-1^\circ$ . The normal position, as indicated on the tail unit (Fig. 9) and on the stabilizer trim indicator (7,7), is labelled '0'. The '0' mark is actually  $+2^\circ$  relative to the fuselage thrust line. The limit positions are indicated on the tail unit by red stripes and + (plus) and - (minus) notations.

The stabilizer trim switch (7,8) is located on the left instrument console. The electric motor will run for as long as the switch is displaced from its spring-loaded 'Off' position. As the stabilizer reaches its upper or lower limits of movement, the drive motor is switched off by the stabilizer incidence relay unit (8,7). The stabilizer incidence is monitored by an indicator (7,7) on the left instrument console. For further details see Part 9A 'General Equipment'.

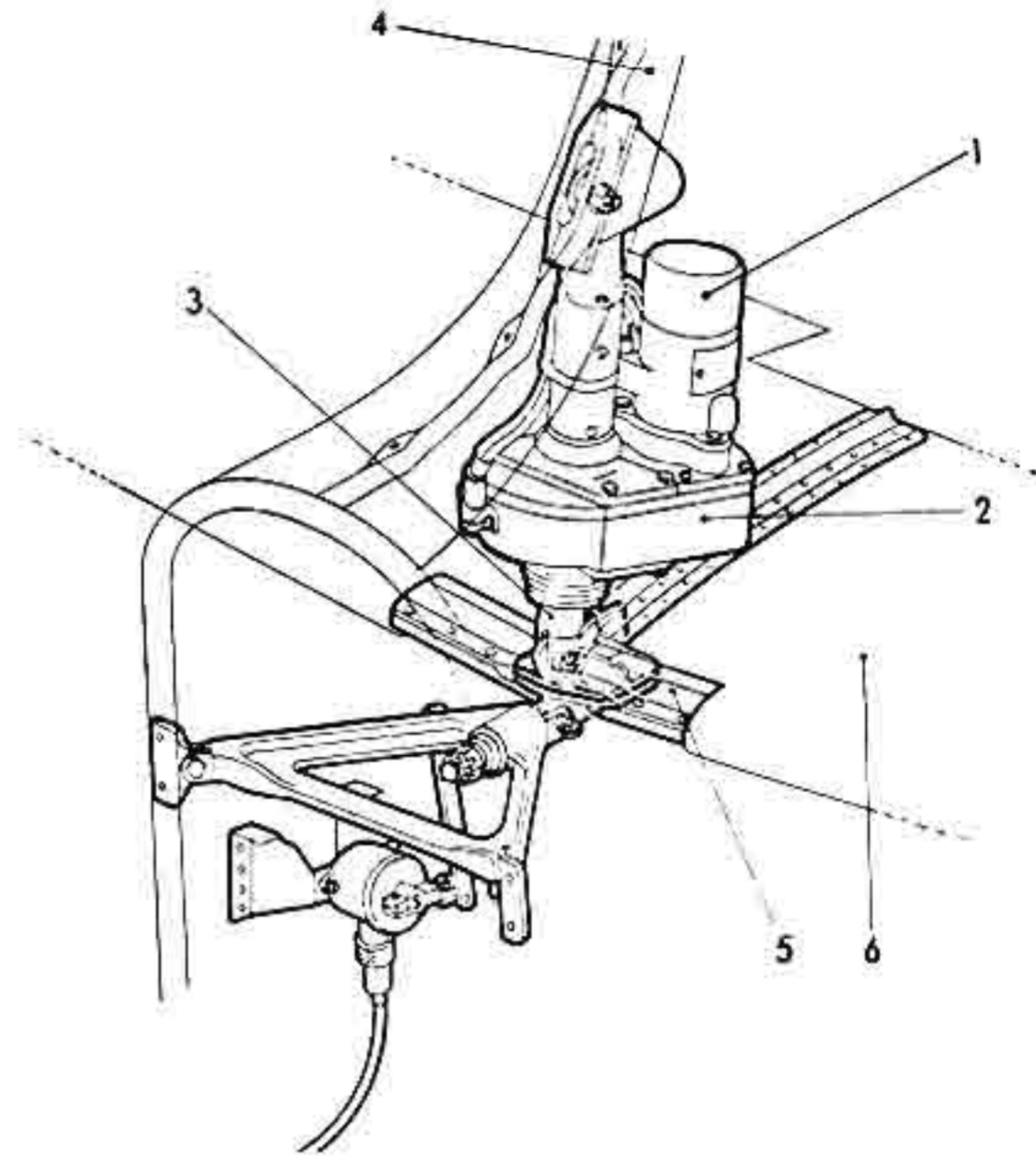

- |                     |                                       |
|---------------------|---------------------------------------|
| 1 Electric motor    | 4 Vertical stabilizer                 |
| 2 Worm-gear housing | 5 Leading edge upper attachment point |
| 3 Drive spindle     | 6 Horizontal stabilizer               |
|                     | 7 Stabilizer incidence relay unit     |

Fig. 8: Stabilizer trim unit

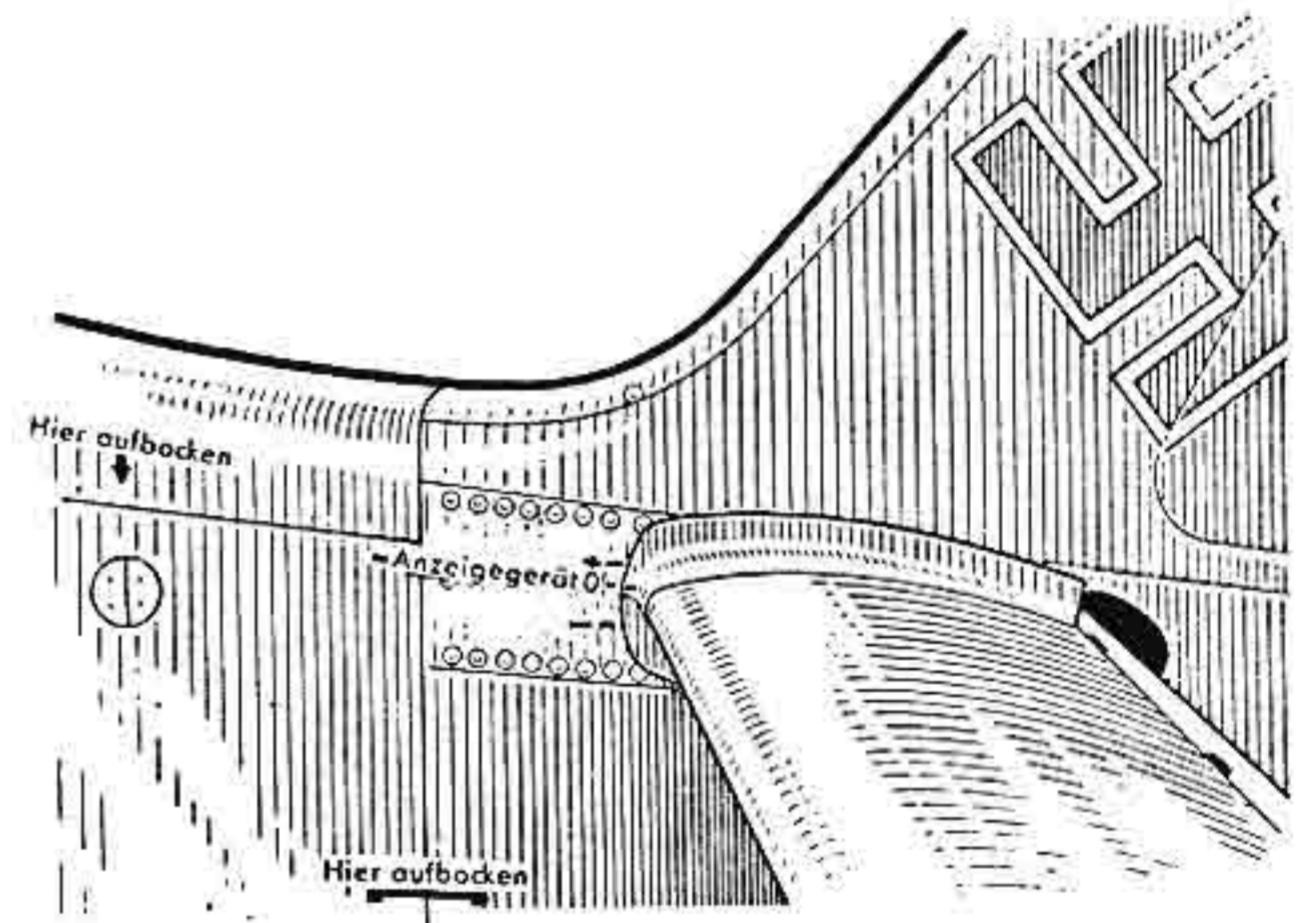

Fig. 9: Stabilizer markings on tail unit



**D. (Luft) T. 2190 A-8**

**For Official Use Only!**

# **Fw 190 A-8**

**Aircraft Handbook**

**Part 5**

**Wing assembly**

**(Effective July 1944)**

**Issued September 1944**

# Description

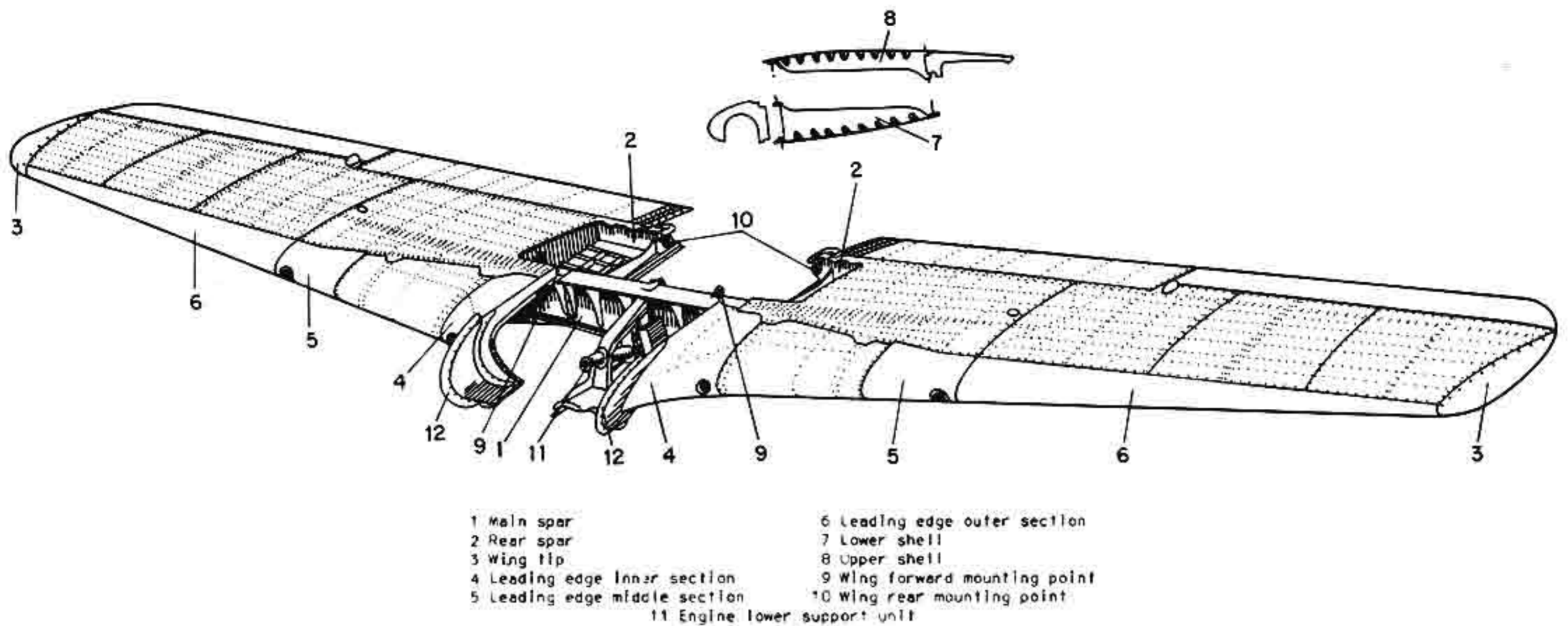

Fig. 1: Wing unit (wheel cover panels removed)

The wing is of one-piece construction. The main spar (1,1) joins the right and left wing panels; while the rear spar (1,2) is divided by the fuselage.

The wing is of all-metal monocoque construction. It is divided into two shells, the lower one containing the main spar (1,7), and the upper one, the rear spar (1,8). Both are full load bearing members. The skin panels are stiffened by ribs and stringers, and are riveted together.

The leading edge panels and tip units (1,3) are screwed onto the wing panels and are detachable. The leading edge unit comprises inner (1,4), middle (1,5) and outer sections (1,6). The wing tip houses a navigation light.

The main spar and skin panels together bear wing load stresses, while the skin panels alone bear wing torsional stresses.

On the main spar are positioned the mounting units for the main gear and the wing guns.

The aileron controls and the flap drive motors are contained within the wings. Weapon, undercarriage, and flap actuation components are accessible through detachable servicing panels on the undersurfaces of the wings.

The wing main spar is attached to Bulkhead 1 by hexagonal bolts (1,9) which attach to both sides of the fuselage. The two portions of the rear spar are each attached by a single bolt (1,10) to either side of Bulkhead 4. Streamlined fairings cover the main spar attachment points.

The engine lower support unit (1,11) is attached to the wing centre section. Positioned on this unit are two hinge mounts, to which the main wheel doors are

attached. A mounting lug, onto which the fuel cell cover plate is attached, is fixed to the lower part of the main spar.

Upon retraction, the main wheels lie in the area between the leading edge inner section (2,4) and the engine lower support unit (2,3). The wheels are protected against engine generated heat by wheel cover panels (2,1).

Aileron and flap mounting points are attached to the wing trailing edges and wing lower surfaces respectively.

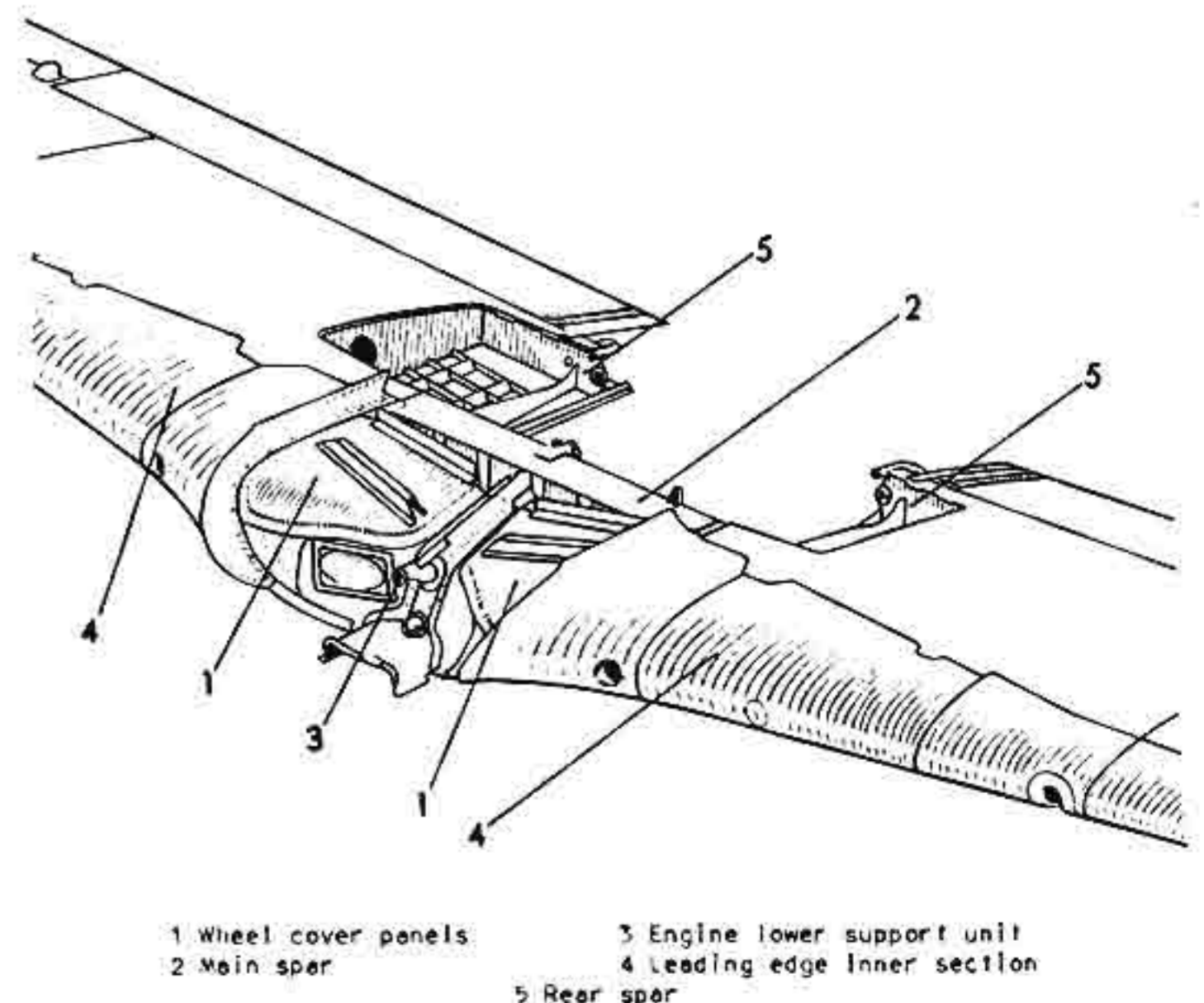

Fig. 2: Wheel cover panels



**D. (Luft) T. 2190 A-8**

**For Official Use Only!**

# **Fw 190 A-8**

**Aircraft Handbook**

**Part 6**

**Powerplant**

**(Effective July 1944)**

**Issued September 1944**

## Description

### 1. General

The aircraft powerplant is a BMW 801D.

The BMW 801D is an aircooled, 14-cylinder, fuel injection engine with two-stage supercharger, reduction gearing and engine cooling fan.

The engine operates on the four-stroke combustion principle with fuel injected directly into the cylinders, and has, for supercharging, a single impeller unit with two self-setting speed ratios.

In flight, the operation of the engine is governed by a control unit. This unit regulates boost pressure, engine RPM, fuel mixture, ignition-timing adjustment, and the supercharger switchover control; the pilot need only operate the throttle lever. The control unit is attached to the right side of the accessory casing. Special pressure and drain pumps are fitted to circulate the system's hydraulic fluid. This oil is housed in the engine mounting ring.

The powerplant is outfitted with a primer fuel injection system. This system sprays primer fuel into the boost lines of all 14 cylinders. See Part 7 'Engine operation and fuel supply system' for more information about the system.

A number of fighter-bombers equipped with the BMW 801D are outfitted with a C-3 (96-octane) supplementary fuel injection system. This system

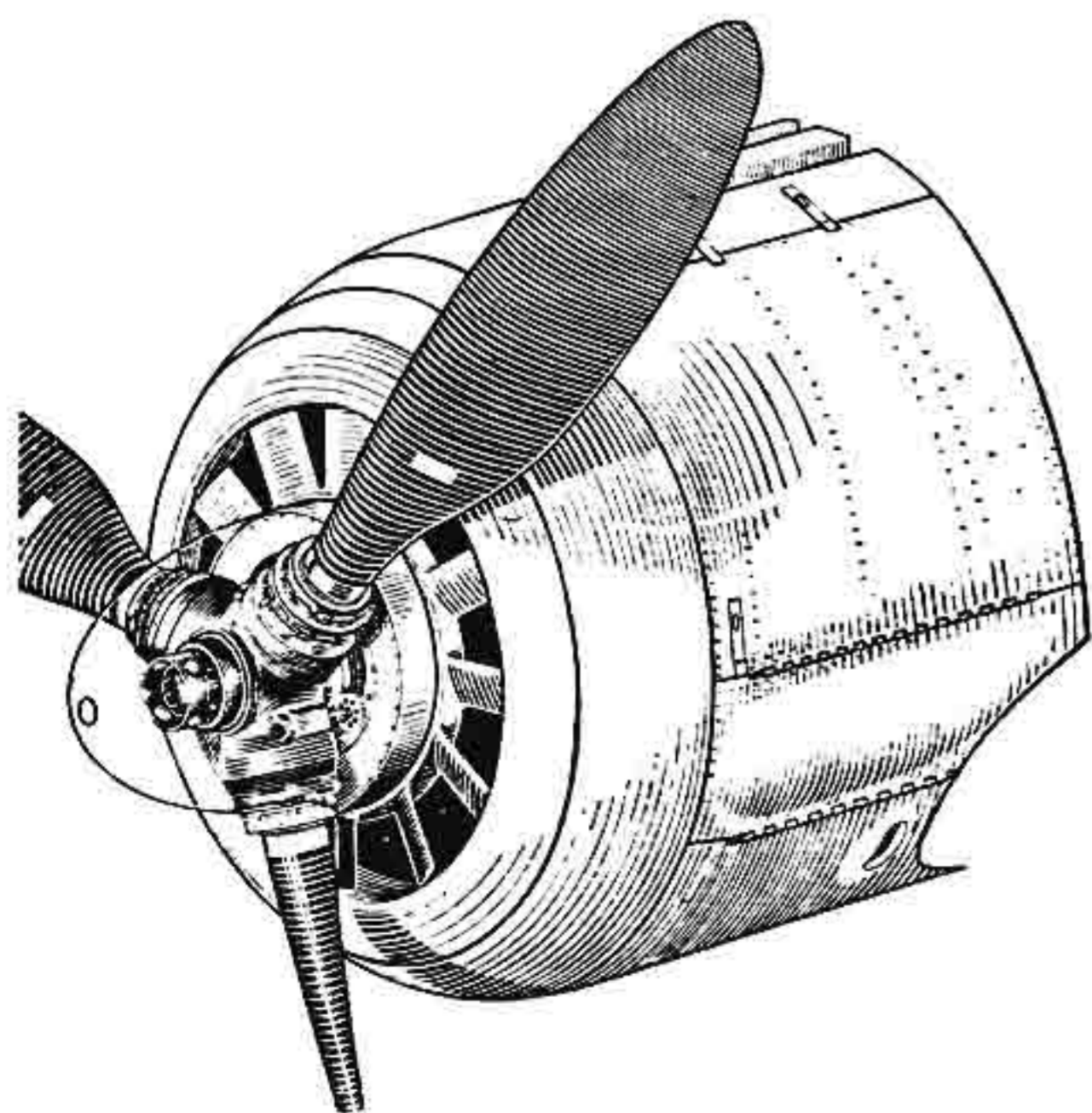
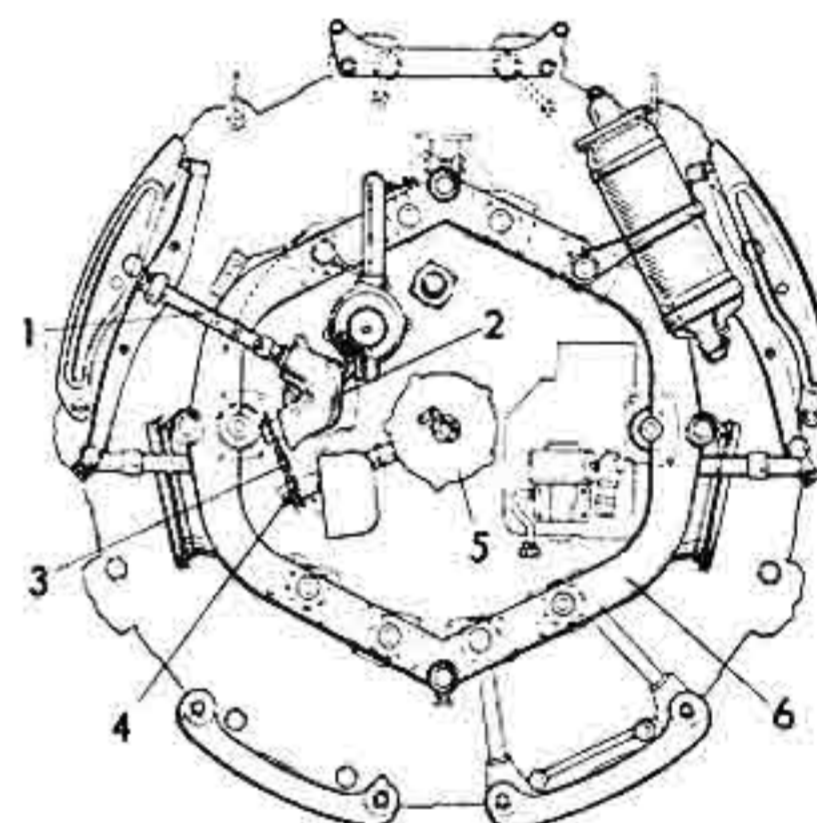

Fig. 1\*: Powerplant

provides short term increases in the emergency top speed at altitudes below 1000 m (3280 ft). For more details on this system see Part 7 'Engine operation and fuel supply system'.

A newer method of increasing the emergency speed of the fighter has been to insert a pilot operated stop cock in the pressure line of the boost regulator. The result is that, at 2700 rpm, the boost pressure, at low setting can be increased to about 1,58 ata (22.4 psi), and at high setting, to about 1,64 ata (23.3 psi). When this system is incorporated, C-3 supplementary fuel injection is no longer necessary and is, therefore, omitted.

### 2. Starter system



- |                |                        |
|----------------|------------------------|
| 1 Torsion tube | 4 Torsion bar          |
| 2 Gear box     | 5 Inertial starter     |
| 3 Drive chain  | 6 Engine mounting ring |

Fig. 2: Starter installation

An inertial starter is used to start the engine; it can be energized either electrically or manually. It is fastened to the accessory casing by a central nut.

The electrical starter switch is located on the right instrument console. The starter crank is inserted in the powerplant left side; it is stored in the equipment compartment; to the right of the access panel.

The turning motion of the starter crank on the torsion tube (2,1) is ultimately transmitted to the starter (2,5) in the sequence shown in Fig. 2.

When the starter is energized manually, the starter brushes are disengaged by a handle which is positioned on the lower left side of the auxiliary instrument panel.

### 3. Ignition system

The engine ignition current is supplied by a Bosch twin-magneto which is mounted on the engine nose casing.

The two ignition circuits are electrically isolated from one another; one serves the spark plugs near the inlet valves, the other serves those near the outlet valves. Each plug is fired individually, ignition timing being regulated by the control unit.

### 4. Supercharger air intake

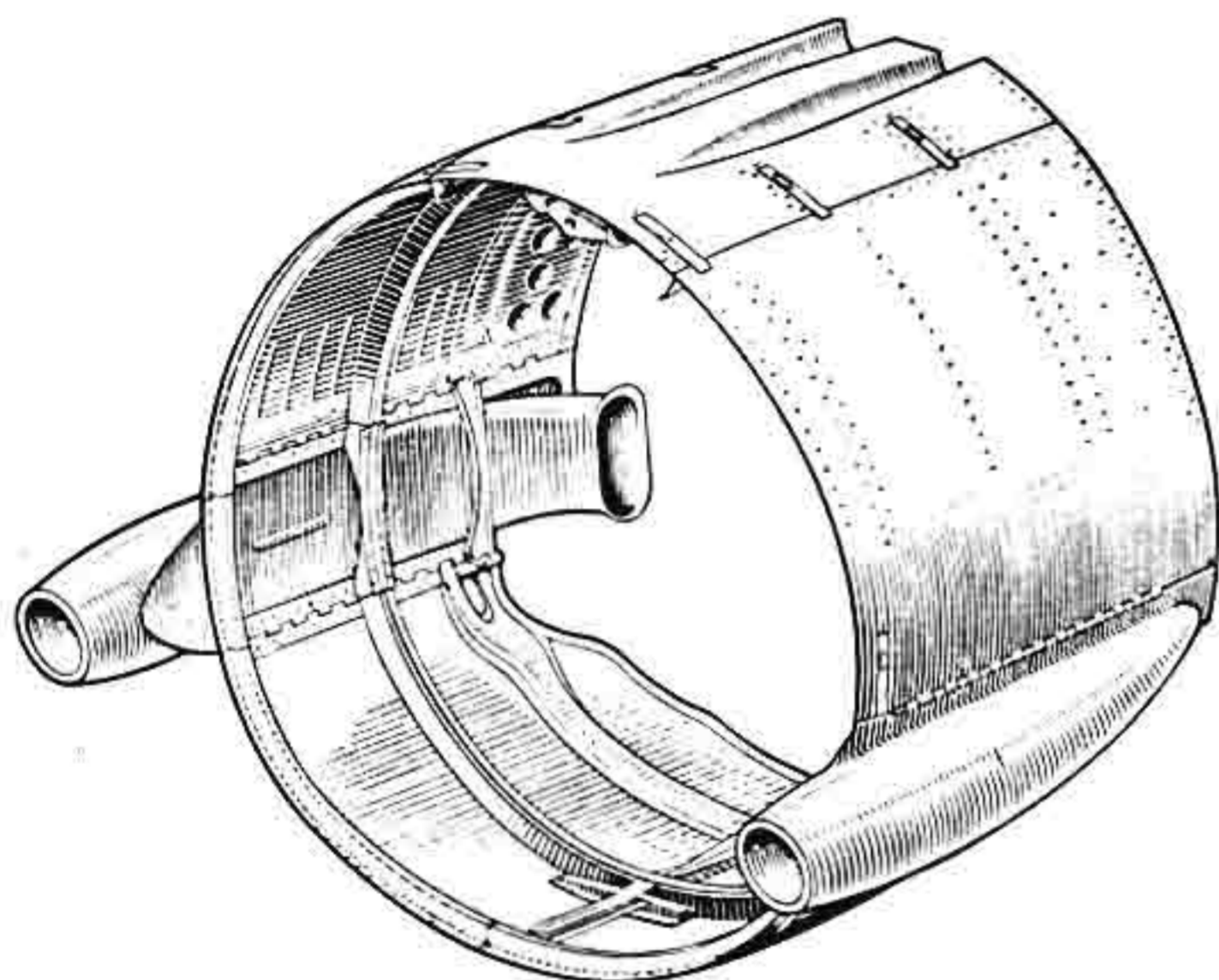

Fig. 3\*: Centre cowling with external air intakes

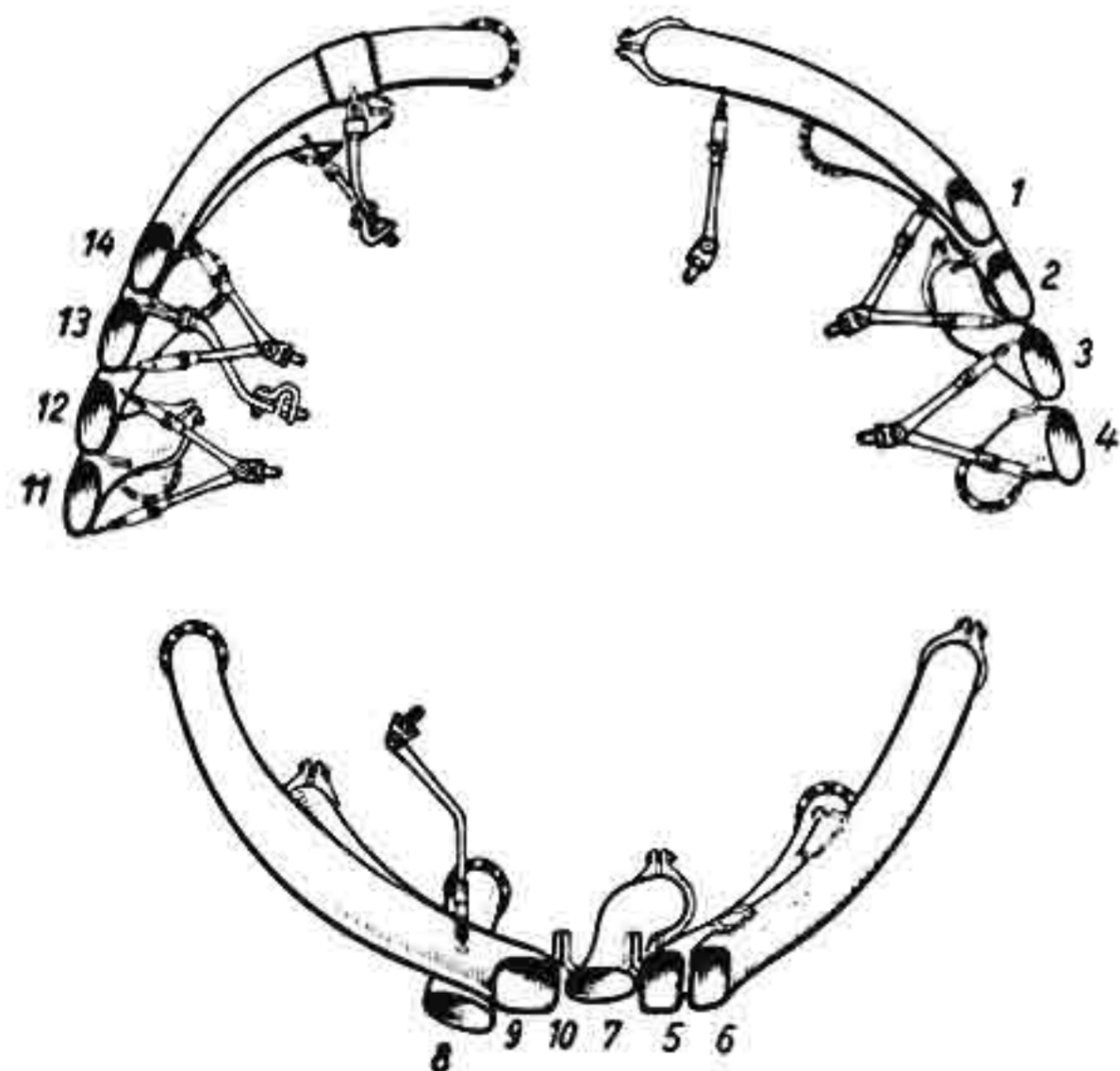

Fig. 4: Exhaust system arrangement  
(the numbers indicate the cylinder numbers to which the exhaust pipes belong)

Intake air is delivered, by the cooling fan located at the front of the engine, through two shallow ducts (6,1) (positioned on either side of the cowling) to two air intakes. Dust filters, which prevent the entry of foreign objects, are fitted onto the intake openings.

Tests have been made on the use of air ducts with external intakes (Fig. 3) on various types of aircraft—especially fighters. The installation of this type of duct will result in improved performance above the rated altitude of the engine through increased dynamic air pressure. Beneath that altitude, engine performance is better when using the interior ducts.

### 5. Exhaust system

The exhaust system (Fig. 4) consists of twelve pipes, divided into three groups, which expel exhaust gases past the side and bottom panels of the engine cowling.

Each side unit comprises four pipes; each pipe is individually attached to the engine by support struts.

Five pipes belong to the bottom group. Those of Cylinders 9 and 10 are welded together to form a common unit. The three pipes from Cylinders 5, 7, 9 and 10 are joined together. The Cylinder 6 pipe is welded to that of Cylinder 5; the Cylinder 8 pipe is attached to the combined Cylinder 9 and 10 pipe, which is, in turn, attached to the engine by a support strut.

The side exhaust units are to be so positioned that the distance between the pipe inboard edges and the fuselage side panels is approximately three times as great as the distance between the pipe outboard edges and the cowling skin.

### 6. Powerplant truss

The powerplant truss, which supports the engine mounting ring, consists of the engine bearer assembly and the engine lower support unit.

The engine bearer assembly (5,1) comprises six welded steel tubes which serve as the top and two side pickup points for the engine mounting ring (5,2). This assembly is attached to the firewall (Bulkhead 1) at four points.

The engine lower support unit consists of the engine lower support strut (5,6), the MG 131 casing chute attachment strut (5,7), and the wheel door attachment and support struts (5,8). The unit is fixed, at its rear end to the lower edge of the main spar, and at its forward end to the engine mounting ring. The support strut (5,6) is adjustable in length.

The engine is attached to the mounting ring by ten bolts which pass through the ring and screw into rubber shock mounts fixed to the rear of the engine.

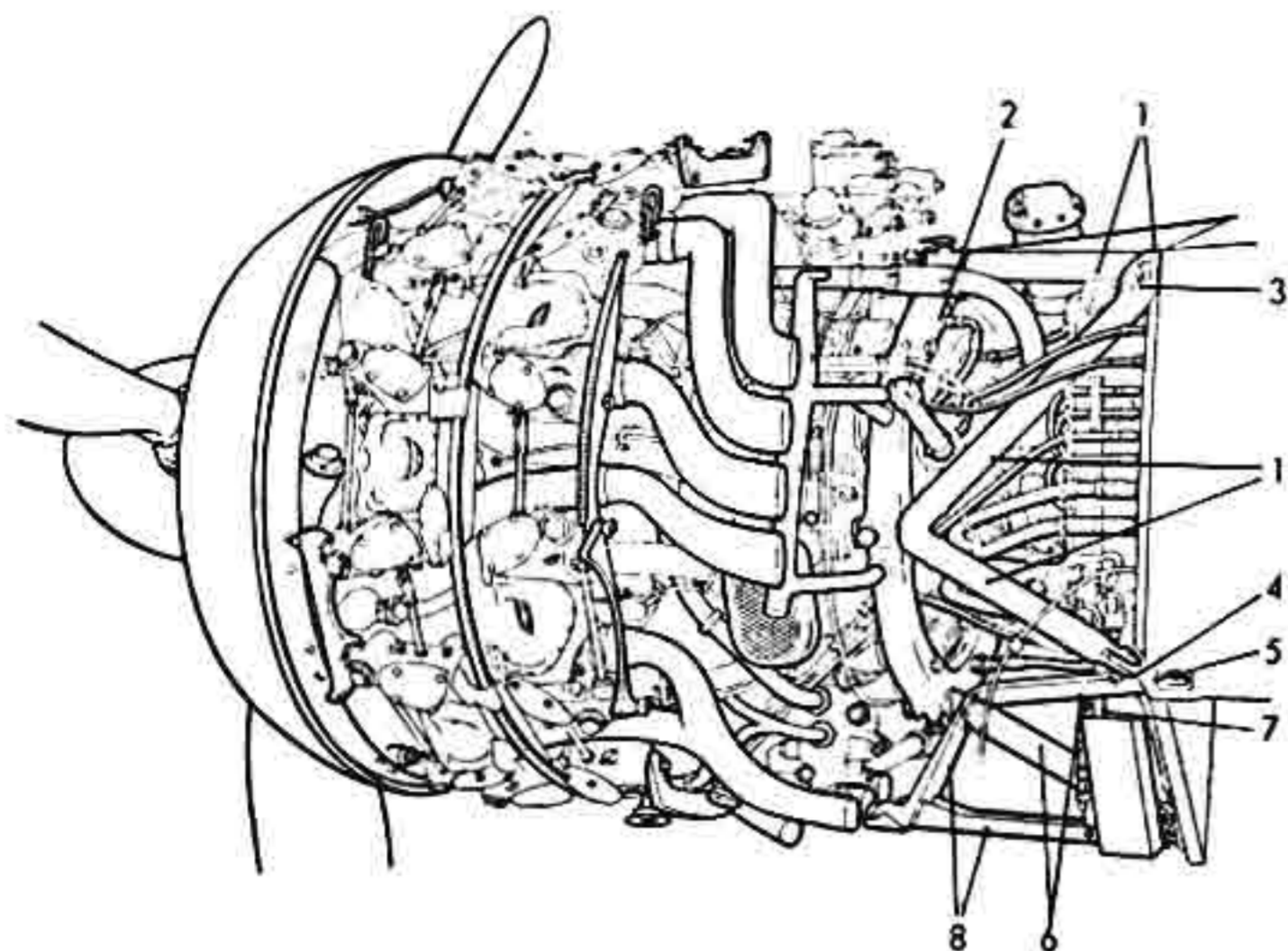

- |                          |  |
|--------------------------|--|
| 1 Engine bearer assembly | 5 Main spar mount                          |
| 2 Engine mounting ring   | 6 Engine lower support strut               |
| 3 Upper attachment point | 7 MG 131 casing chute attachment strut     |
| 4 Lower attachment point | 8 Wheel door attachment and support struts |

Fig. 5: Powerplant truss

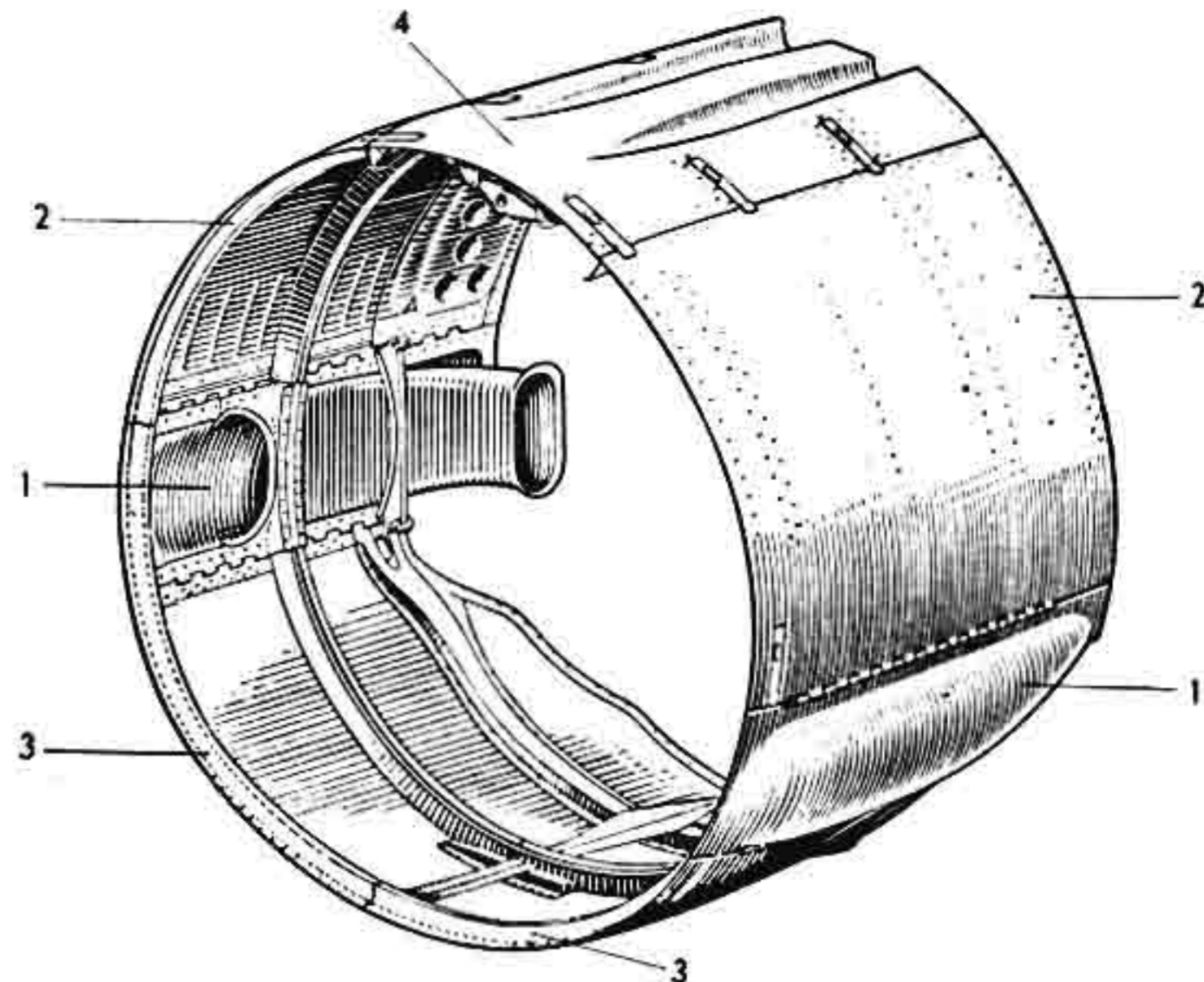

- |                                     |                |
|-------------------------------------|----------------|
| 1 Side panels with air intake ducts | 3 Lower shells |
| 2 Side shells                       | 4 Upper panel  |

Fig. 6\*: Cowling centre section

## 7. Engine cowling

The engine cowling consists of three interconnected components: the forward section which includes the armoured rings protecting the oil cooler and oil tank (see Part 8D 'Special fittings'), the centre section, and the powerplant rear fairings which enclose the engine accessories area and form the transition to the fuselage (see Fig. 9,4 and 5 in Part 1 'Fuselage').

The cowling centre section comprises two side panels (6,1) which serve as air intake ducts, two side shells (6,3), and an upper panel (6,4). The side and lower shells are attached to the side panels by hinges. The upper shell is fixed, at the rear to a mounting bracket (7,5) atop the engine, and at the front to the cowling forward section. The two side shells which, when open, can be used as servicing platforms, are prevented from opening too far by restraining wires which attach to the engine lifting rings (see Fig. 8).

The side and lower shells have toggle clips; the side shells also each have a quick-release fastener.

Onto the inner side of the upper panel are built the following: in the centre, a tube for cockpit ventilation; and, on either side, cooling pipes for the fuselage weapons ammunition boxes.

The hinge pins which connect the side panels to the side and lower shells, also fix them to brackets (7,1) on either side of the engine. At their forward ends, all components of the cowling centre section lie against a rubber seal positioned along the outer rim of the circular oil tank. The side shells are also supported by semi-circular fittings (7,1)

against which they lie. The lower shells, secured to one another by toggle clips, lie against two semi-circular fittings (7,3) which are screwed to the bottom of the engine.

The support brackets (7,6) which attach to both sides of the engine mounting ring support both the fuselage armament cover and the fuselage side panels and act as pickup points for the side panel screw locks.

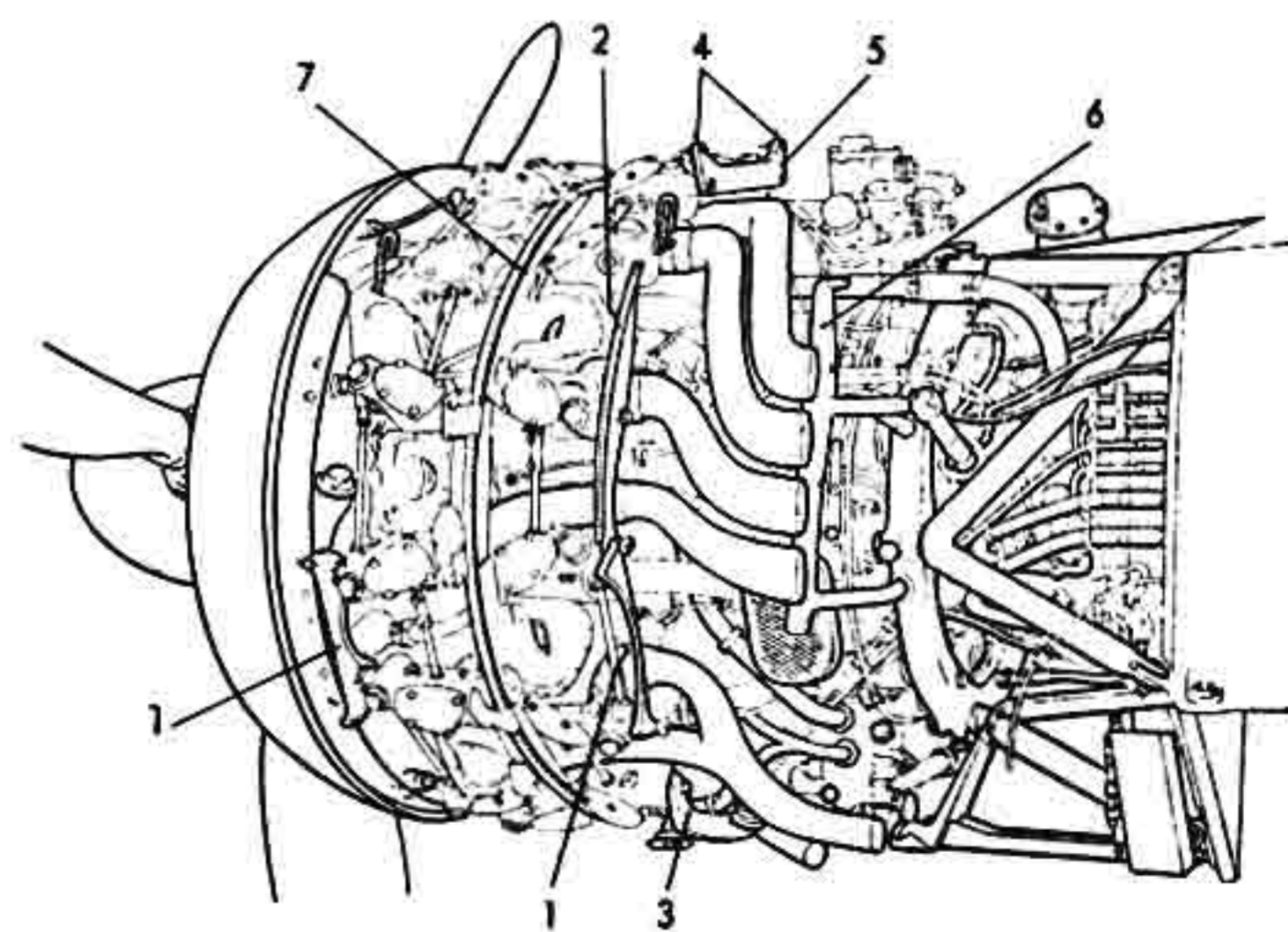

- |                       |   |
|-----------------------|---|
| 1 Side panel support  | 4 Upper panel attachment bracket              |
| 2 Side shell support  | 5 Support bracket on the engine mounting ring |
| 3 Lower shell support | 6 Airtight wall with rubber sealing ring      |

Fig. 7: Centre cowling support and attachment points

To avoid cooling losses, the baffles of the forward and rear cylinders are joined to form an airtight wall (7,7) which is sealed to the cowling by a rubber ring around its circumference.

As the forward edges of the cowling are also tightly sealed, the air required for combustion, for engine cooling and for oil cooling cannot escape this area unused.

The powerplant rear fairing comprises three panels. The upper one (fuselage armament cover) is attached to the windscreen mounting bracket and opens upward. The two side panels are hinged to the wing assembly and open downwards; they contain the engine cooling flaps (see Part 7 'Engine operation and fuel system').

## 8. Airscrew

The aircraft is fitted with a three bladed, constant speed airscrew of 3300 mm (10'10") diameter.

Inflight blade pitch adjustment is normally automatic (dependent on RPM), being controlled hydraulically from the control unit. The pitch can also be adjusted manually, eg. when the automatic pitch control fails, and on the ground.

To change from hydraulic (automatic) to electrical (manual) pitch adjustment, move the pitch control switch on the left instrument console to the 'Manual' position. The propeller pitch can then be adjusted by depression of the appropriate side of the thumb switch on the throttle lever; this switch has two settings: 'RPM increase' and 'RPM decrease'. When released, the switch returns to the neutral 'Off' position.

The pitch control unit, with attached switchover motor and RPM governor, is built onto the forward left side of the engine. Propeller pitch is monitored mechanically by an indicator on the auxiliary instrument panel right side.

Limit switches prevent the movement of the propeller blades past their allowable pitch limits.

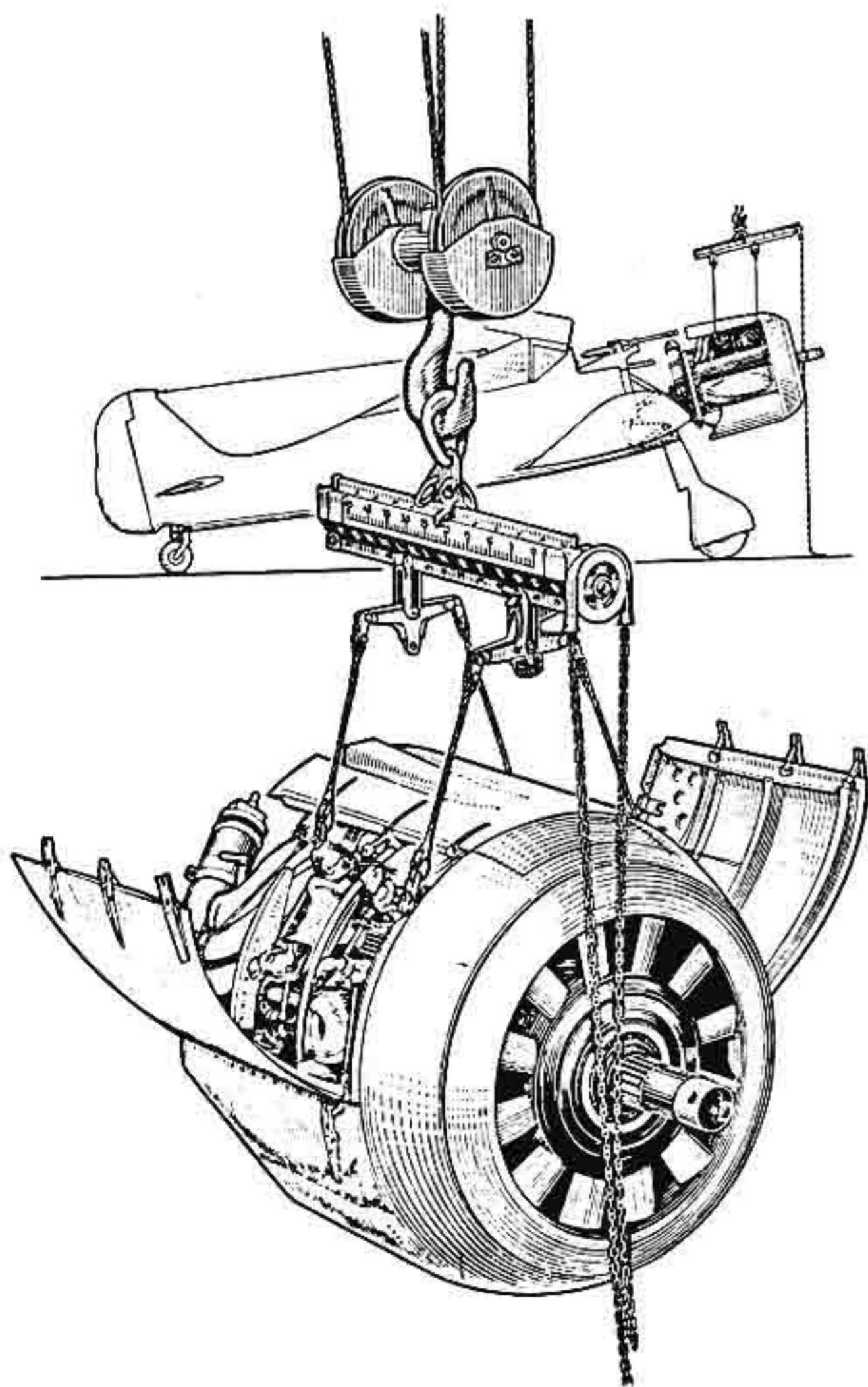

Fig. 8\*: Engine in lifting harness



D. (Luft) T. 2190 A-8

For Official Use Only!

# **Fw 190 A-8**

Aircraft Handbook

**Part 7**

**Engine operating and fuel supply system**

**(Effective July 1944)**

**Issued September 1944**



## Description

### A. Engine operating system

The following notations refer to Part 9A, Fig. 1.

On the left instrument console is positioned the throttle lever (1,11); and, on the auxiliary instrument panel, the fuel tank selector lever (1,18), the engine starter brushes withdrawal knob (1,14), and the fuel cut-off control lever (1,13).

The cooling flap actuation crank (1,31), with its position indicator, is situated at the bottom of the main instrument panel. After use, the crank handle is folded back.

The throttle lever (3,1) can be locked to maintain a predetermined setting by tightening the throttle friction knob (3,8). Throttle lever movement is transmitted to the control unit performance adjustment lever as shown in Fig. 3,1-6.

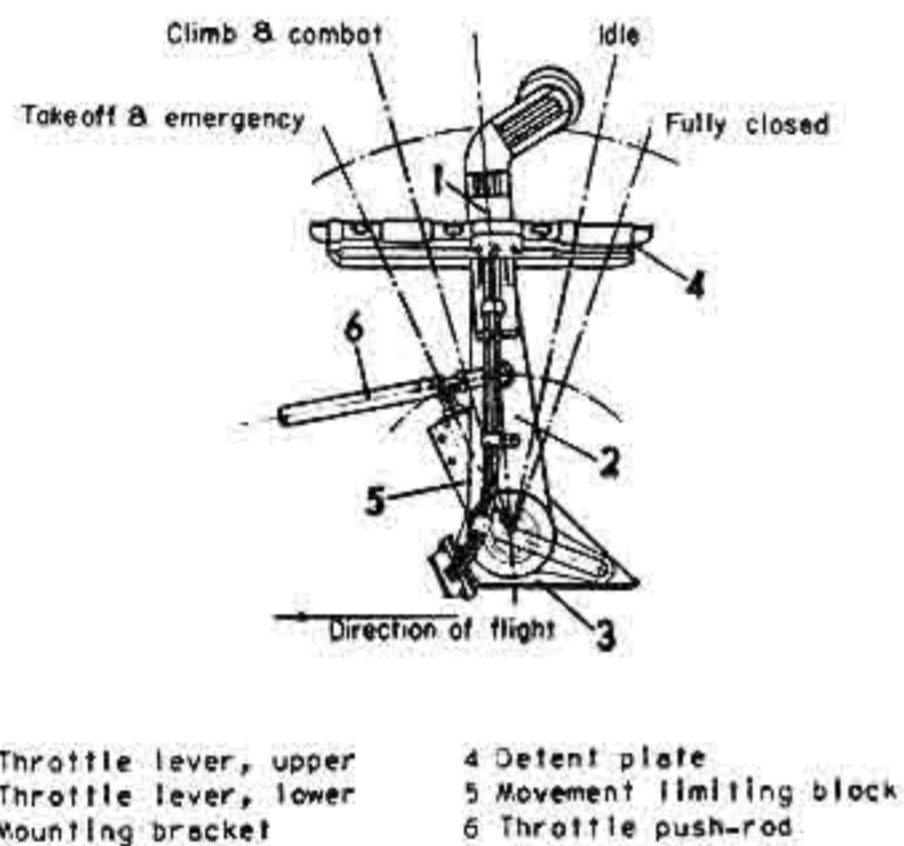
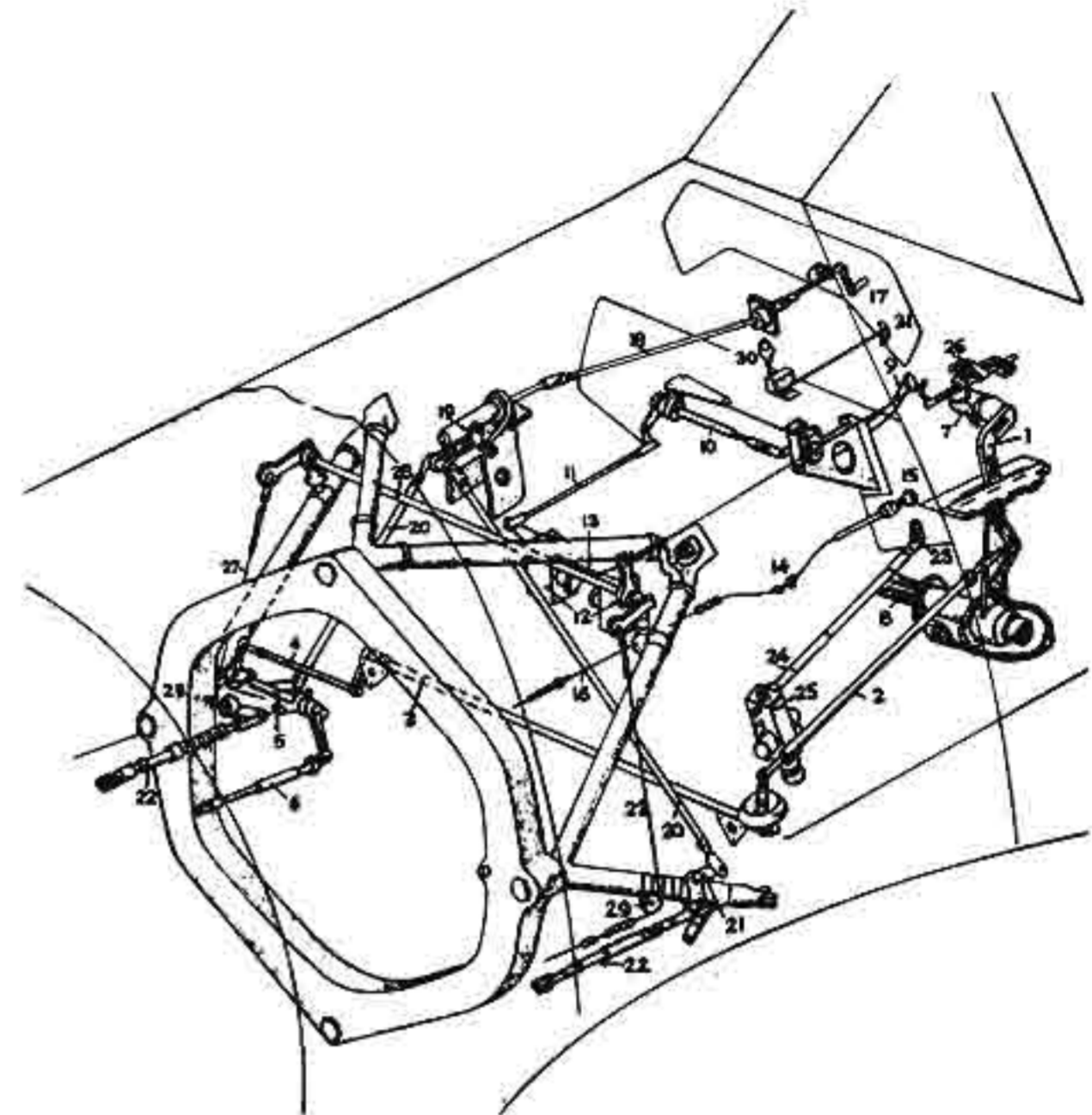

Fig. 2: Throttle diagram

The pilot adjusts the throttle lever in accordance with the supercharger pressure indication rather than by throttle position alone. Moving the throttle and thereby the performance adjustment lever of a stopped engine to the Inflight setting should be avoided, because due to lack of hydraulic assist, its subsequent movement to the fully closed position will take greater effort than when the engine is running.

Movement of the fuel tank selection lever (3,9) is transmitted by a torsion bar (3,10) and push-rod (3,11) to the right fuel valve (3,12). The fuel valves, interconnected by a square shaft (3,13), are positioned on a fitting on the rear of the firewall (Bulkhead 1). The lever settings are:

- "Auf" (Open)
- "Vorderer behälter zu" (Forward tank closed)



- |   |   |
|---|---|
| 1 Throttle lever                            | 16 Starter brushes withdrawal cable                     |
| 2 Throttle push-rod                         | 17 Cooling flap actuation crank with position indicator |
| 3 Torsion bar behind firewall               | 18 Drive rod  |
| 4 Push-rod                                  | 19 Torque conversion unit                               |
| 5 Torsion bar in front of firewall          | 20 Push-rod   |
| 6 Control unit performance adjustment lever | 21 Bellcrank  |
| 7 Thumb actuated propeller pitch control    | 22 Adjustable length push-rod                           |
| 8 Throttle friction knob                    | 23 Cut-off valve control lever                          |
| 9 Fuel tank selector lever                  | 24 Torsion bar  |
| 10 Torsion bar with actuation lever         | 25 Fuel cut-off valve                                   |
| 11 Push-rod                                 | 26 Tropical filter flap actuation handle                |
| 12 Fuel valves                              | 27 Cable  |
| 13 Fuel valve coupling shaft                | 28 Torsion bar with actuation lever                     |
| 14 Grease nipple                            | 29 Pulley   |
| 15 Engine starter brushes withdrawal button | 30 Valve with mounting bracket                          |
|   | 31 Actuation button with push-rod                       |

Fig. 3: Engine operation (overview)

- "Hinterer behälter zu" (Rear tank closed)
- "Zu" (Closed)

The cooling flaps are actuated from the cockpit by a hand crank (3,17); and their position indicated on a scaled plate. The transmission train is illustrated in Fig. 3,17-22. The coupling collars on the actuation rods (3,22) serve as separation points; these rods are adjustable in length. They must be adjusted to place a prescribed tension on the cooling flaps and thereby prevent their inadvertent opening in flight.

#### Important!

At "0" flap opening, the actuation rods must be set to a tension of 40 kg (88.2 lb); otherwise, there is a possibility of the flaps being

there is a possibility of the flaps being pulled

open by the slipstream during high speed flight. Before opening the fuselage side panels ensure that the flaps are opened about 10°.

The starter brushes withdrawal button (3,15) is positioned on the auxiliary panel left side; a cable (3,16) attaches it to the brush withdrawal mechanism on the starter unit.

The fuel cut-off control lever (3,23) is spring-loaded to the 'Open' position. During the fuel pump check it must be held in the 'Closed' position. The control lever is connected by a shaft (3,24) to the cut-off valve (3,25) which is positioned on the left filter housing.

## B. Fuel system

See also Fig. 4.

The fuel system comprises two fuselage tanks (4,1

and 4,2); and, if required, an auxiliary fuel tank (Fig. 5) within the fuselage fixed to the rear of Bulkhead 8, and a jettisonable fuel tank (4,26) beneath the fuselage.

Use of the additional tanks is dependent upon the type of mission undertaken. To house the fuel required for increased ranges, either the drop tank (300 Ltr/66,2 gal) or the auxiliary tank (115 Ltr/25,3 gal), or both (415 Ltr/91,5 gal), can be fitted. On a mission with both additional tanks fitted, the drop tank is emptied first, so that, in an emergency, it can be discarded.

### 1. Basic fuel system (main tanks only)

The main fuel tanks are contained in a special compartment beneath the cockpit. This compartment is divided into two by a vertical wall and is sealed by a screw fastened cover panel.

Both fuel tanks are fitted with electrical fuel pumps (4, 8). The pumps start operating as soon as

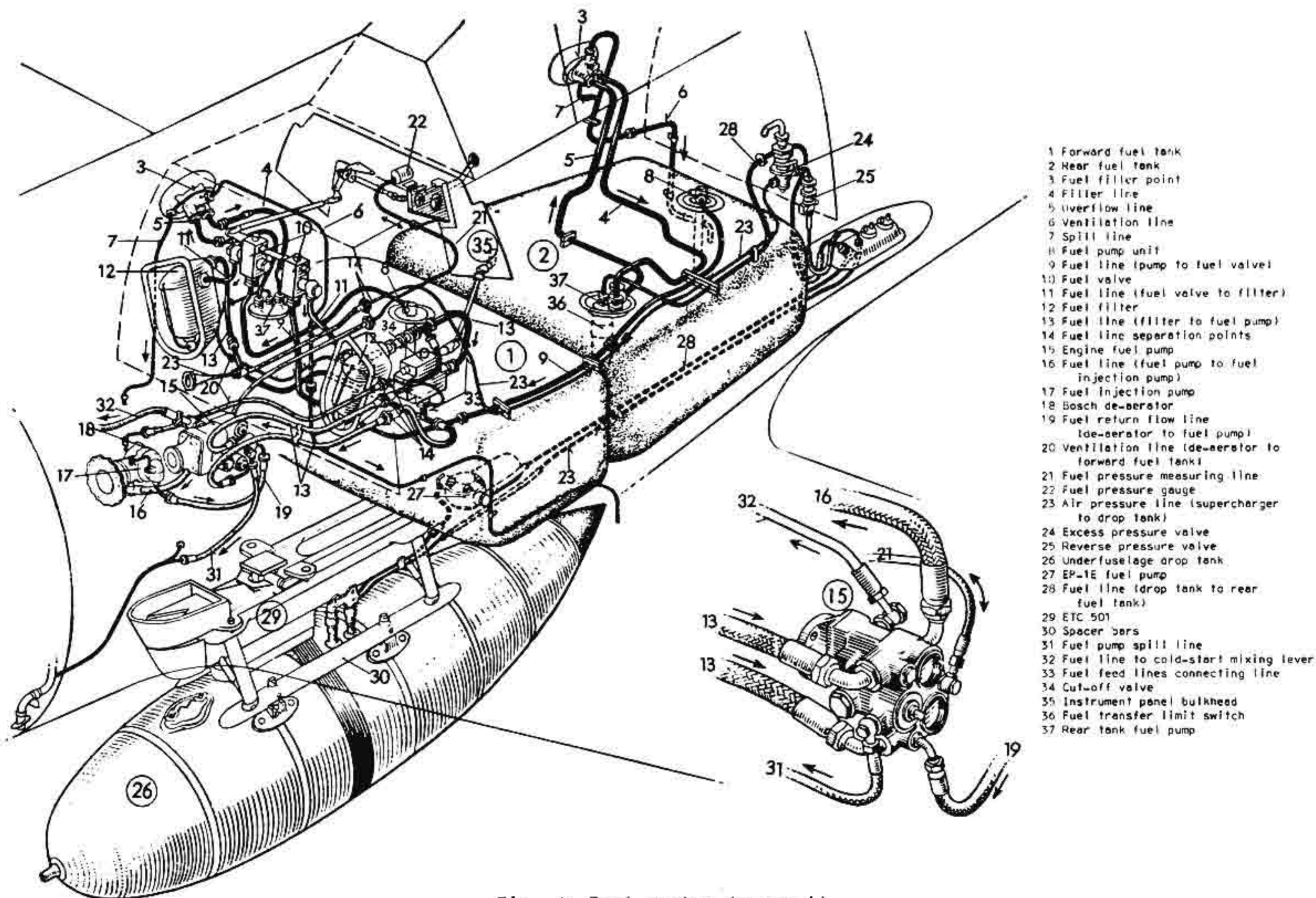

- 1 Forward fuel tank
- 2 Rear fuel tank
- 3 Fuel filler tank
- 4 Filter line
- 5 Overflow line
- 6 Ventilation line
- 7 Spill line
- 8 Fuel pump unit
- 9 Fuel line (pump to fuel valve)
- 10 Fuel valve
- 11 Fuel line (fuel valve to filter)
- 12 Fuel filter
- 13 Fuel line (filter to fuel pump)
- 14 Fuel line separation points
- 15 Engine fuel pump
- 16 Fuel line (fuel pump to fuel injection pump)
- 17 Fuel injection pump
- 18 Bosch de-aerator
- 19 Fuel return flow line (de-aerator to fuel pump)
- 20 Ventilation line (de-aerator to forward fuel tank)
- 21 Fuel pressure measuring line
- 22 Fuel pressure gauge
- 23 Air pressure line (supercharger to drop tank)
- 24 Excess pressure valve
- 25 Reverse pressure valve
- 26 Underfuselage drop tank
- 27 EP-1E fuel pump
- 28 Fuel line (drop tank to rear fuel tank)
- 29 ETC 501
- 30 Spacer bars
- 31 Fuel pump spill line
- 32 Fuel line to cold-start mixing lever
- 33 Fuel feed lines connecting line
- 34 Cut-off valve
- 35 Instrument panel bulkhead
- 36 Fuel transfer limit switch
- 37 Rear tank fuel pump

Fig. 4: Fuel system (general)

the appropriate circuit breakers (1,57) on the right instrument console are depressed, and they serve to support the action of the engine mounted (Maihak) pump (4,18).

A fuel gauge (1,36), positioned on the auxiliary instrument panel, measures the contents of each fuel tank individually; switching to the desired tank is via a selector lever (1,43). The fuel gauge reads correctly in level flight.

The forward tank is fitted with a fuel low level device. A red warning lamp (1,41) positioned on the right auxiliary instrument panel illuminates at approximately 90-100 Ltr (20-22 gal) (Return-to-base warning). A fuel low level device is also fitted in the rear tank; it causes a white light to illuminate when the contents fall to 10 Ltr (2.2 gal) (Tank switch-over warning).

The fuel pressure is monitored by a gauge (1,20) on the auxiliary instrument panel.

Each tank is provided with a separate filler point (4,3) on the fuselage right side. Fuel is poured through the filler line (4,4) until it begins to back up to the external filler connection via the overflow line (4,5). Fuel tank ventilation is accomplished at the appropriate filler point (ventilation line (4,6)); ventilation of the Bosch float-and-pendulum de-aerator (4,18) takes place through the forward filler point. The spill tube for the rear filler point connects into the rear tank ventilation line; that for the forward tank filler point connects to the fuselage lower surface. The fuel lines (4,9 & 4,11) run from the appropriate tank fuel pump (4,8) to the engine fuel pump (4,18).

Into each fuel line is built a fuel valve (4,10) and filter (4,12). The filters are set into suitable apertures (filter housings) on the forward side of the firewall. This siting of the filters prevents gas fumes from reaching the cockpit. The right filter connects into the forward tank fuel line; the left one, into the rear tank fuel line. The two filter housings are connected by a spill line which connects into the one from the forward filler point; it prevents the accumulation of fuel at the bottom of the housings of leaky filters. The two fuel lines are connected to one another by a line which contains a cut-off valve (4,34) which remains open during all normal powerplant operation. This ensures that both suction chambers of the Maihak fuel pump always contain fuel even when one tank is empty.

## 2. Fuel system with drop tank

The drop tank (4,26) is suspended from the shackles of the Type 500 release gear within the ETC 501 rack by a metal band. The drop tank is connected to the rear fuel tank (4,2) by a fuel line (4,28). An EP-1E fuel pump (4,27) is built into the line at the rear of the rack. An air line (4,23) leads from the supercharger to the drop tank and contains both an

excess pressure (4,24), and a reverse pressure (4,25), valve. Rubber sleeves (system separation points) connect the fuel and air lines to the drop tank.

Fuel is forced from the drop tank to the rear fuel tank by air pressure drawn from the supercharger. This action is aided by the EP-1E fuel pump which begins to run as soon as the "Abwurfbehälter" circuit breaker is depressed.

When the supercharger pressure is less than that of the surrounding air, the EP-1E fuel pump alone feeds the fuel to the rear tank. A fuel transfer limit switch (4,36), built into the rear tank fuel pump (4,37), regulates fuel flow from the drop tank. With the drop tank fitted, fuel is drawn from the rear fuel tank until its contents have fallen to 240 Ltr (53 gal). At that point the transfer limit switch opens and permits drop tank fuel to flow into the rear tank until the drop tank is empty.

The drop tank contents are monitored as follows: when, after the limit switch has opened, the rear tank fuel contents sink below 240 Ltr, the drop tank is empty. This does not result in the switching off of the supercharger air pressure.

## 3. Fuel system with auxiliary tank

Old: Self-sealing tank.

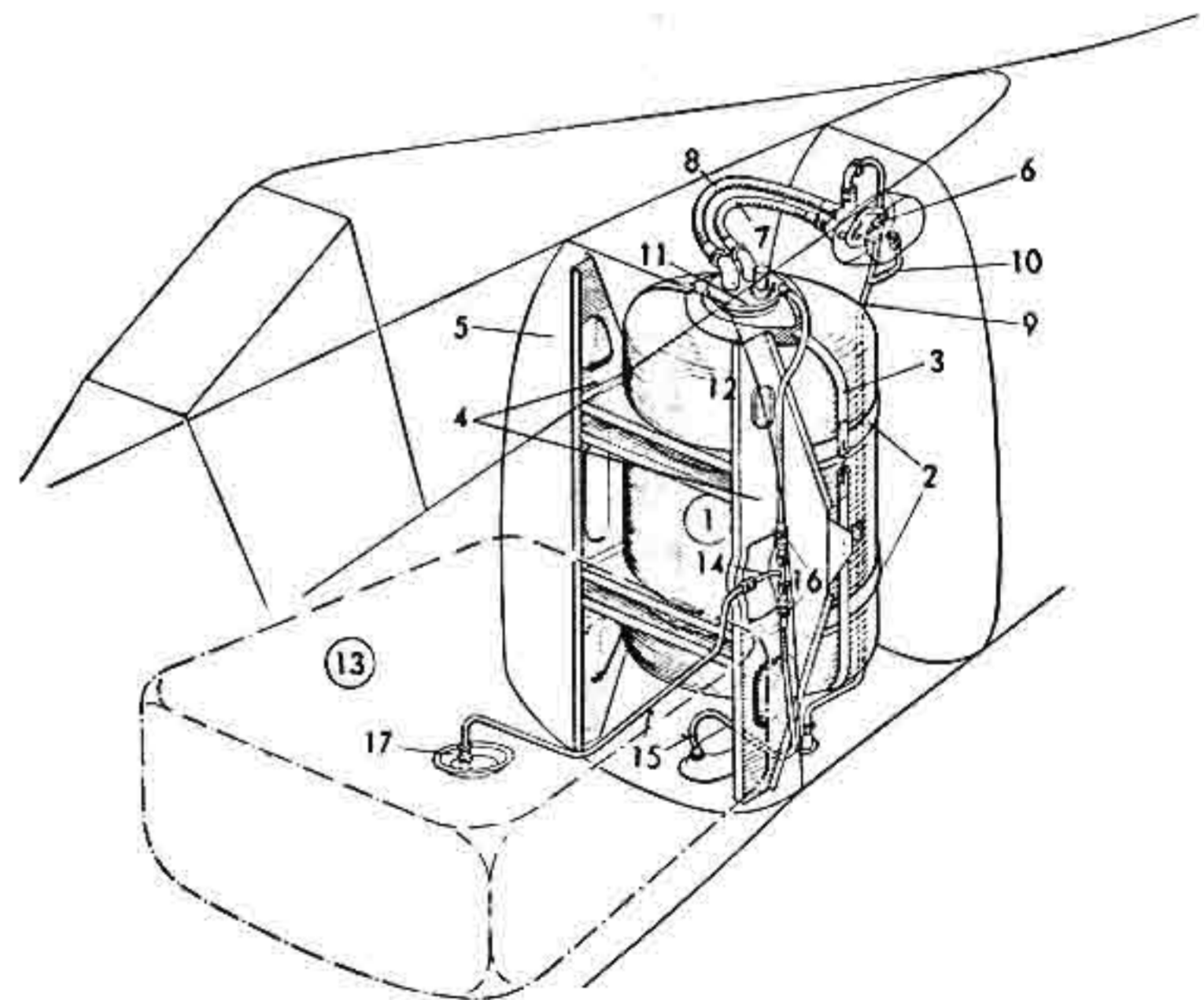

- |                       |                                       |
|-----------------------|---------------------------------------|
| 1 Auxiliary fuel tank | 9 Ventilation line                    |
| 2 Horizontal straps   | 10 Spill line                         |
| 3 Vertical strap      | 11 Tank line/pump unit                |
| 4 Tank housing        | 12 Fuel line                          |
| 5 Bulkhead B          | 13 Rear fuel tank                     |
| 6 Fuel filler point   | 14 I-joint                            |
| 7 Filler line         | 15 Fuel line (Drop tank to rear tank) |
| 8 Overflow line       | 16 Check valves                       |
|                       | 17 Filler head                        |

Fig. 5: Rear fuselage auxiliary tank

New: Non self-sealing tank with drain cock and supercharger air pressure fuel jettison.

A description of the new system will be added upon completion of the relevant construction documents!

The auxiliary fuel tank is fastened to a housing (5,4) at the rear of Bulkhead 8 (5,5) by two straps (5,2 & 3) and is fueled through a filler point (5,6) on the left fuselage between Bulkheads 9 and 9a. During fueling, the fuel flows through the filler line (5,7) to the tank; when the tank is full, the fuel backs up the overflow line (5,8) to the filler point, and from there, via a ventilation line (5,9) out the bottom of the fuselage. The fuel spill line (5,10) also connects into the ventilation line.

On the top of the tank is positioned a unit (5,11) containing the fuelling, overflow and feed lines as well as the fuel pump. The electric fuel pump starts operating as soon as the "Kraftstoffpumpe Zusatzbehälter Rumpf" circuit breaker is depressed.

Fuel flows through a feed line (5,12 & 15) to the rear tank (5,13). Connecting into this line is a T-joint (5,14) with the drop tank fuel line. A check valve (5,16) is installed before the T-joint in each of the two lines. This prevents the flow of fuel from one auxiliary tank to the other; or, when one of these two tanks isn't fitted, prevents loss of fuel through the unconnected feed line.

The fuel transfer limit switch (5,17) regulates the flow of fuel from the auxiliary tank in the same way as for the drop tank.

There is no monitoring of auxiliary tank contents; the tank is empty when the rear tank fuel level falls below 240 Ltr.

### C. Emergency power system

See Fig. 6.

An engine emergency power system is provided for this aircraft. This system is to be installed in accordance with Fw 190 Modification Instruction No. 133.

This system provides, for fighters with non-derated BMW 801D or BMW 801TU powerplants, a short-term increase in power up to the rated altitude of the engine. This emergency power can be maintained in level or climbing flight for up to 10 minutes (Watch the oil temperature!). Because of potential oil and cylinder head cooling problems, it is recommended that during a climb, the system, if feasible, be turned off. During system operation in hot summer weather, the oil temperature will reach maximum permissible limits. This system must only be switched on in flight, at full throttle, and with the propeller pitch control on 'Automatic'.

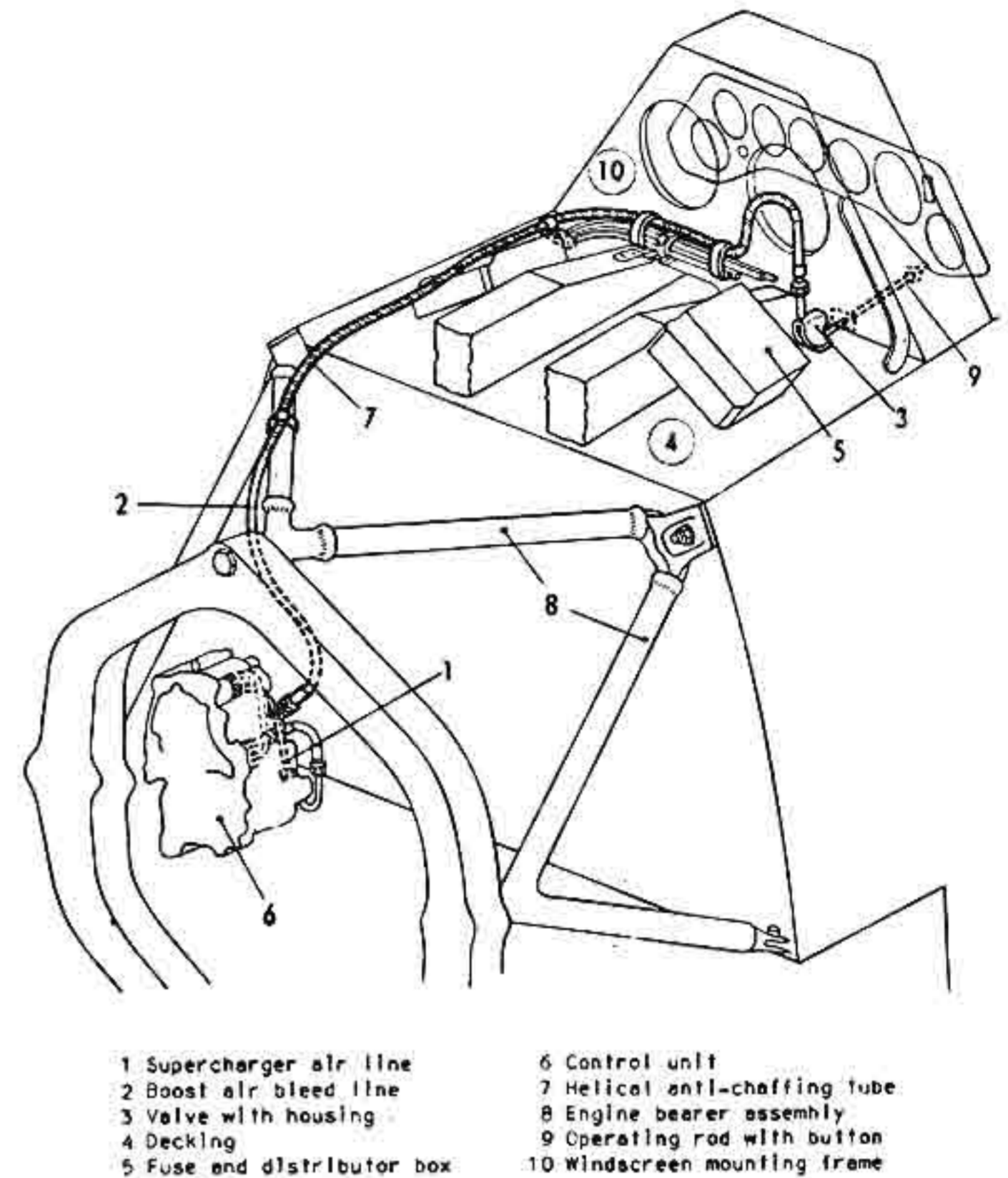

Fig. 6: Emergency power system

The increased power is gained by bleeding air from the supercharger pressure line (6,1), in which are located two nozzles connected in series. A flexible tube (6,2), through which a portion of the boost air can be drawn off when the valve (6,3) is opened, is connected into the supercharger air line between the fuel mixture chamber and the boost pressure regulator. The two nozzles, the first of which has the smaller inside diameter, are so constructed, that when the actuation valve (6,3) is opened, the air pressure within the boost pressure drops to a very low level; this causes the throttle valve to open wide, thereby increasing the maximum obtainable boost pressure, at 2700 RPM, from 1,42 ata, to 1,58 ata at the low supercharger setting, and to 1,65 ata at the high supercharger setting. The higher boost pressure results in increased fuel consumption, due to the greater quantity of fuel injected into the cylinders.

The actuation valve (6,3) is mounted in a housing on the decking in front of the windscreen mounting frame (6,10) and behind the left fuse and distributor box (6,5). The flexible line (6,2) which connects the valve to the supercharger air line is encased within a helical anti-chaffing tube (6,7).

The valve is operated by a button (6,9) located beneath the left side of the main instrument panel.

The following inscription is placed near this button.

Emergency Power  
Pull  
2700 RPM  
L = 1,58; H = 1,65  
Button depressed = Valve 'Closed'  
Button pulled = Valve 'Open'

When the emergency power unit is installed, only the following types of spark plugs can be used:

- a) Bosch DW 240 ET 7/1A
- b) Bosch DW 240 ET 7/1B
- c) Bosch DW 250 ET 7

Spark plug c) is to be used only if spark plugs a) and b) are not available.

Aircraft fitted with this unit are to be marked with a yellow ring (50 mm outside diameter and 10 mm wide) which is to be placed on the rear left corner of the fuselage armament cover.

## D. Primer fuel system

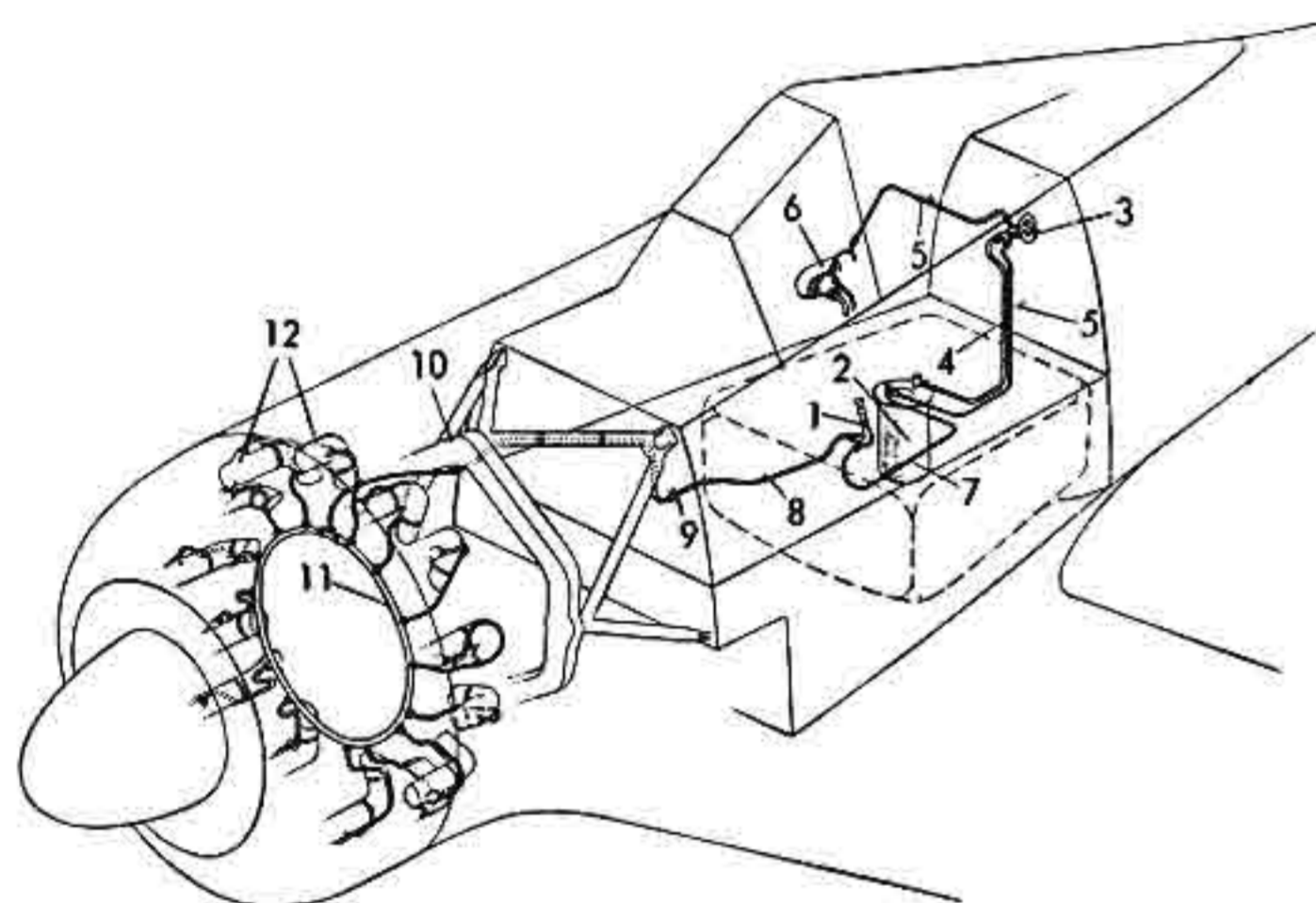

- |                          |  |
|--------------------------|--|
| 1 SUM-Primer pump        | 7 Suction feed line                              |
| 2 Primer fuel line       | 8 Pressure feed line                             |
| 3 Filler point           | 9 Firewall transition point                      |
| 4 Filler line            | 10 Separation point (20) on engine mounting ring |
| 5 Ventilation line       | 11 Circular feed line harness                    |
| 6 Rear tank filler point | 12 Supercharger air pressure pipes               |

Fig. 7: Primer fuel system

This system facilitates engine starting by spraying primer fuel into the supercharger air pressure pipes of all 14 cylinders, and there atomizing it.

The system includes:

- 1 AP-20 SUM-Primer pump
- 1 tank with filler point and associated feeder lines.

The primer fuel tank (7,2), which is contained in

the rear fuel tank, has a capacity of 3 Ltr (5 Qts). The pump (7,1) is positioned at the rear of the left instrument console.

The tank is fueled through a filler point (7,3) which is situated beneath a sliding cover on the forward fuselage left side. The filler point is connected to the primer fuel tank by the filler line (7,4) and ventilation line (7,5).

Another line, which leads from the primer tank filler point to the rear tank ventilation line (7,6), provides for ventilation in flight.

## E. BMW 801D lubrication system

Documentation for the TU-powerplant will follow.

See Fig. 8.

The circular oil tank is positioned in front of the engine and behind the oil cooler (8,6), and is protected by an armoured ring. The tank has a scaled contents measuring probe within the filler cap (8,24); the filler point is located on the left side of the nose. Oil consumption measurement during flight is not possible.

The ring shaped oil cooler is positioned in front of the oil tank and is also protected by an armoured ring. Between the two armoured rings is a gap of about 10 mm for the exit of the cooling air.

During low temperatures, the system is filled with warm oil forced up through Filler Point I (8,18). The oil cooler is filled first, while air is expelled from the system; then the tank is filled. A line connecting the input side of the main pump and the input side of the auxiliary pump is contained within the oil pumping unit; this line enables the excess oil which is delivered by the oversized auxiliary pump to be returned to it.

The warm oil must be hot enough (over 65°C) to allow the thermostat (8,4) to open the radiator flow circuit.

The engine itself is filled with warm oil through a special filler connection (8,19).

### Oil Flow Circuit

Oil is drawn from the tank by the auxiliary pump and fed past the thermostat (8,4). At an oil temperature below 65°C it flows through the warming chamber (8,5) to the main pump; above 65°C it flows through the radiator block (8,6) to the main pump. A temperature probe (8,8) which directs the flow of oil between the auxiliary pump and the cooler, is positioned between the cooler and the main pump.

The main pump then forces the oil to the engine, following which, three engine return pumps feed the hot oil back to the oil tank. The oil flow circuit then begins anew.

To ensure a continuing supply of oil in case of failure of the thermostat or of the cooler, a line connects the output side of the auxiliary pump directly to the input side of the main pump. To guarantee a constant oil pressure of 8 atü (118 psi) to the engine, the main pump has oversized dimensions and is fitted with a shunt line.

The engine ventilation line (8,14) connects into the circular oil tank.

Between the main pump and the engine, the oil passes through an oil filter (8,11) positioned on the engine mounting ring.

**Cold weather starting sequence**

Oil is prepared for cold weather starting by a

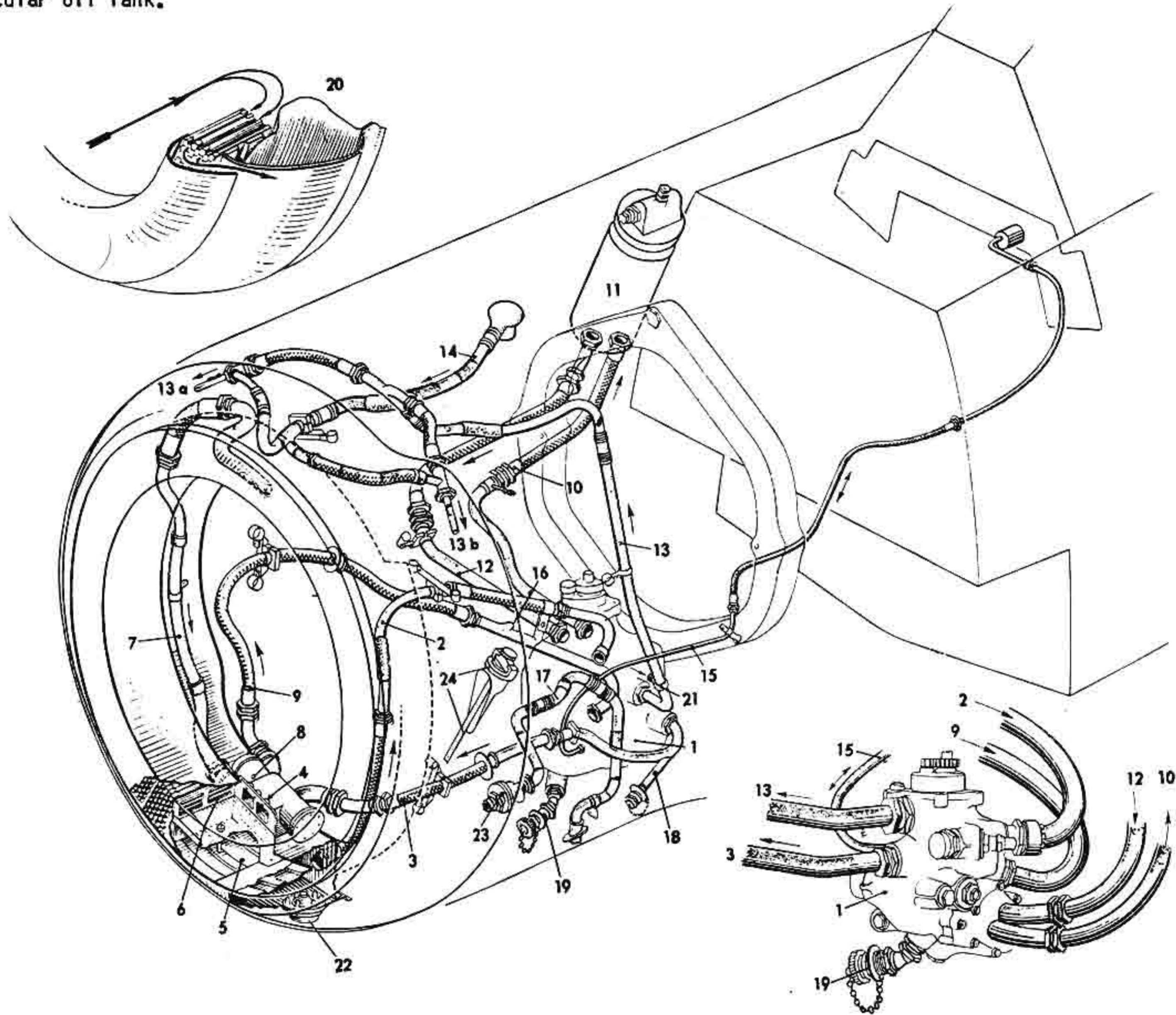

- 1 Engine mounted oil pump
- 2 Input line (tank to pump)
- 3 Output line (pump to thermostat)
- 4 Thermostat
- 5 Oil warming chamber
- 6 Oil cooler block
- 7 Line from cooler to temperature probe
- 8 Temperature probe
- 9 Input line (probe to pump)
- 10 Line from pump to oil filter

- 11 Oil filter
- 12 Line from oil filter to pump
- 13 Line from pump to tank
- 13a Tank inlet line
- 13b Tank inlet line
- 14 Engine ventilation line
- 15 Oil pressure measuring line
- 16 Oil temperature measuring line
- 17 Tank ventilation line
- 18 Warm oil filler point for cooler and tank

- 19 Warm oil filler point for engine
- 20 Path of cooling air through the oil cooler
- 21 Oil mixing nozzle for cold weather starting
- 22 Oil tank drain valve
- 23 Pendulum valve
- 24 Filler cap with contents measuring probe

Fig. 8: BMW 801D Lubrication system

special mixing nozzle (8,21) which is built into the oil return line (8,13).

Fuel is taken from the output side of the Maihak fuel pump and fed through a cut-off valve to the mixing nozzle (a circular tube with fine holes), where it is added to the oil.

To complete the cold weather starting procedures see the Fw 190 Operating Procedures.

Oil temperature (1,15) and pressure (1,14) are monitored by appropriate instruments on the auxiliary instrument panel (1,9).

The various oil lines are colour coded in accordance with DIN L5 and are marked with flow direction arrows.

## F. Aircraft tanks

### 1. Fuel tanks

Fuel: C3 (96 Octane)

#### a. Fuselage tanks

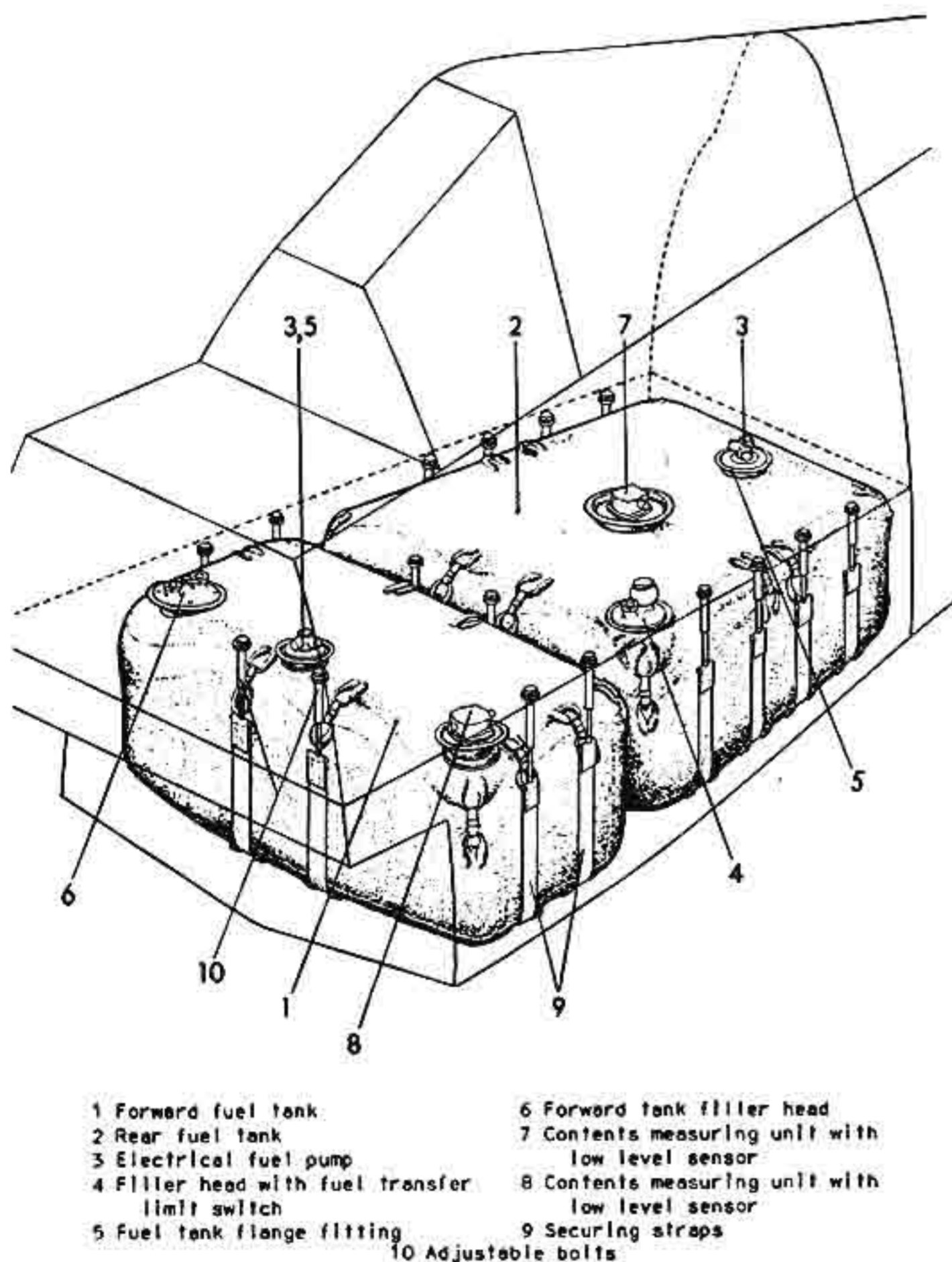

Fig. 9: Main fuel tanks

#### Fueling capacity:

Forward tank at least 232 Ltr (51.0 gal)

Rear tank at least 292 Ltr (64.5 gal).

The two self-sealing fuel tanks (9,1 & 2) are positioned within the fuselage beneath the cockpit. They are held by fabric straps (9,9) which are secured to the cockpit floor by adjustable bolts.

Each tank is fitted with an electrical immersion pump (9,3), a filler head (9,4 & 6) (that of the rear tank also contains a fuel transfer limit switch), and a contents measuring unit (9,7 & 8) with attached fuel low level sensor.

Attached to the filler heads of the two tanks are: a filler line (4,4), and an overflow line (4,5); to that of the forward tank, the de-aerator ventilation line (4,20); and, to that of the rear tank, the auxiliary tanks feed line (4,28).

#### b. Underfuselage drop tank

Fueling capacity: 300 Ltr (66.2 gal).

The drop tank is, when carried, suspended beneath the fuselage from an ETC 501 rack and locked into position by four set screws.

The drop tank is connected to the fuselage feed, and air pressure, lines by rubber sleeves (separation points).

In an emergency, it can be jettisoned by pulling the T-shaped handle labelled "Bomben".

#### c. Rear fuselage auxiliary tank

Fueling capacity: 115 Ltr (25.3 gal).

See Fig. 5.

The auxiliary tank is, when required, mounted behind Bulkhead 8. It is fastened to a support by fabric straps (two horizontal and one vertical).

The tank has a header unit containing a pump, a filler line, an overflow line, and a feeder line.

It is self-sealing.

### 2. Primer fuel tank

See Fig. 7.

Fuel: Aircraft primer fuel.

Fueling capacity: Approximately 3 Ltr (5 Qts).

The tank (7,2) is contained within the rear fuel tank. It is filled via an external filler point (7,3).

The tank is protected by its location within the rear tank.

### 3. Oil tank

Oil tank capacity: 55 Ltr (12 gal).

Oil tank contents must not be permitted to fall below 20-25 Ltr (4.4-5.5 gal).

Oil type: Only Intava-Redring.

The ring shaped oil tank (10,1) is located within the aircraft nose. It is filled through a fuelling nozzle (8,24) on the aircraft nose left side. Oil is drained from the tank by opening the SUM-tank drain valve (10,10), after attaching an oil drain tube to it.

The tank is protected against gunfire by an armoured ring (10,8).

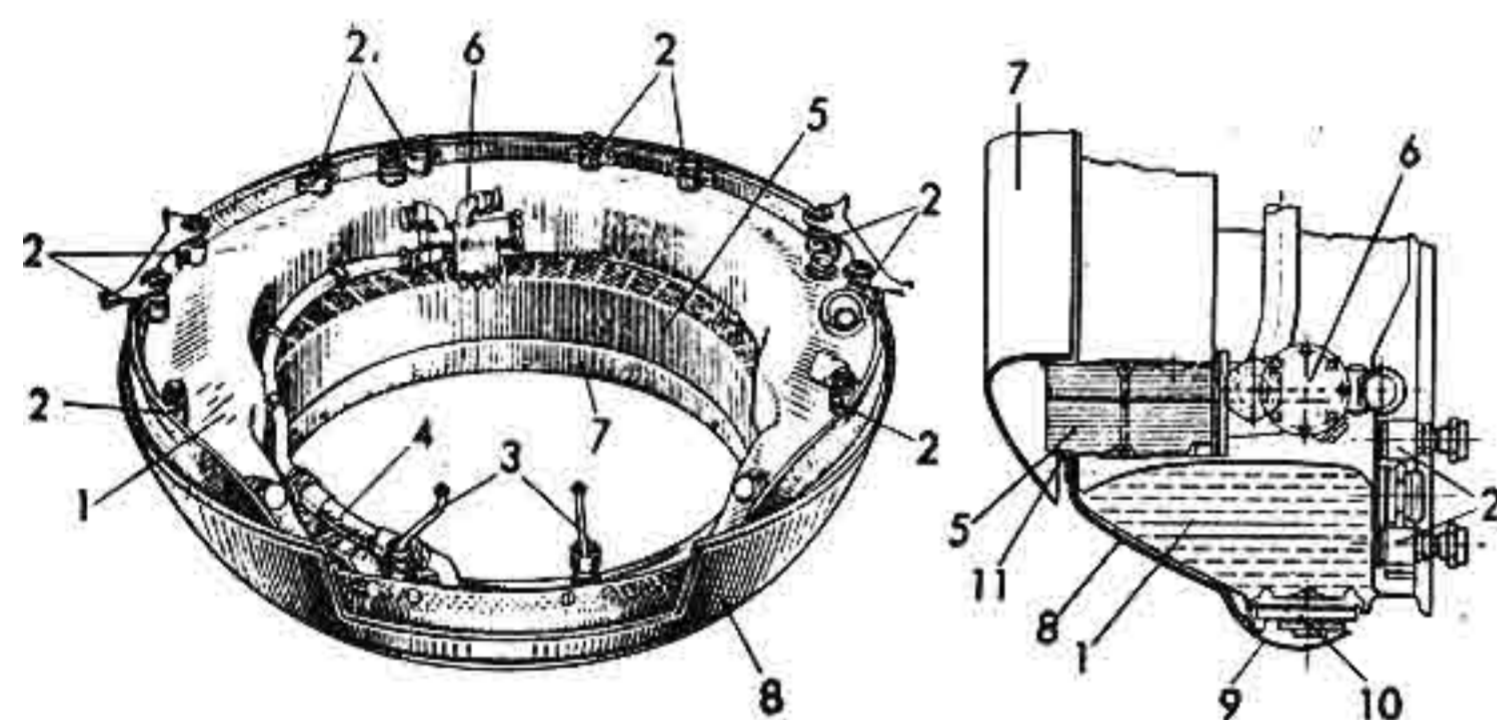

- |                         |                     |
|-------------------------|---------------------|
| 1 Oil tank              | 6 Thermostat        |
| 2 Rubber shock mounting | 7 Cooler armour     |
| 3 Connecting lines      | 8 Oil tank armour   |
| 4 Oil lines             | 9 Cover             |
| 5 Cooler                | 10 Tank drain valve |
|                         | 11 Cover segment    |

Fig. 10: BMW 801D armoured oil cooler and tank

### 4. Control unit oil tank

The engine mounting ring serves as control unit oil tank. It is filled to the level of the filler opening (located on the upper left side of the ring).

Capacity: 5,6 Ltr (4,9 Qts).

Caution!

Add oil only immediately after running up the engine. Reason: when the engine has been sitting for some time, the control unit fills with oil and the oil level within the mounting ring sinks. If the tank is then filled, when the engine is started, the extra oil in the control unit will attempt to move back to the tank. The resulting excess pressure in the system will probably damage both the control unit and the mounting ring.

A thin temperature-resisting oil mixture is used, the mixing ratios for summer and winter are:

Summer mixtures:

80% Redring + 20% Spindle oil green  
(Shell AB 11)  
or 90% Redring + 10% Hydraulic oil 0435

Winter mixtures:

50% Redring + 50% Spindle oil green  
(Shell AB 11)  
or 70% Redring + 30% Hydraulic oil 0435

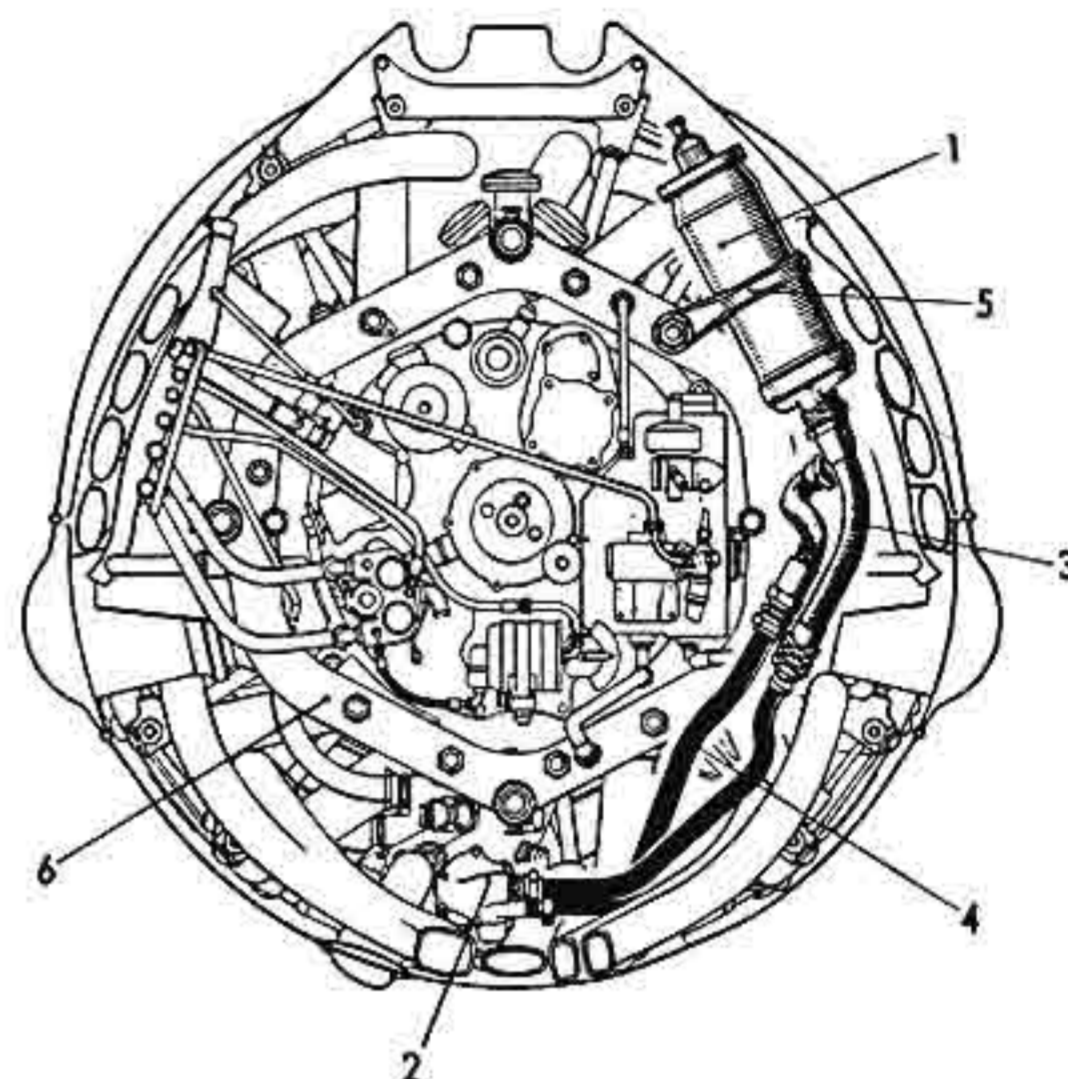

- |                            |                            |
|----------------------------|----------------------------|
| 1 Oil filter               | 4 Line from filter to pump |
| 2 Oil pump                 | 5 Securing clamp           |
| 3 Line from pump to filter | 6 Engine mounting ring     |

Fig. 11: BMW 801D oil filter



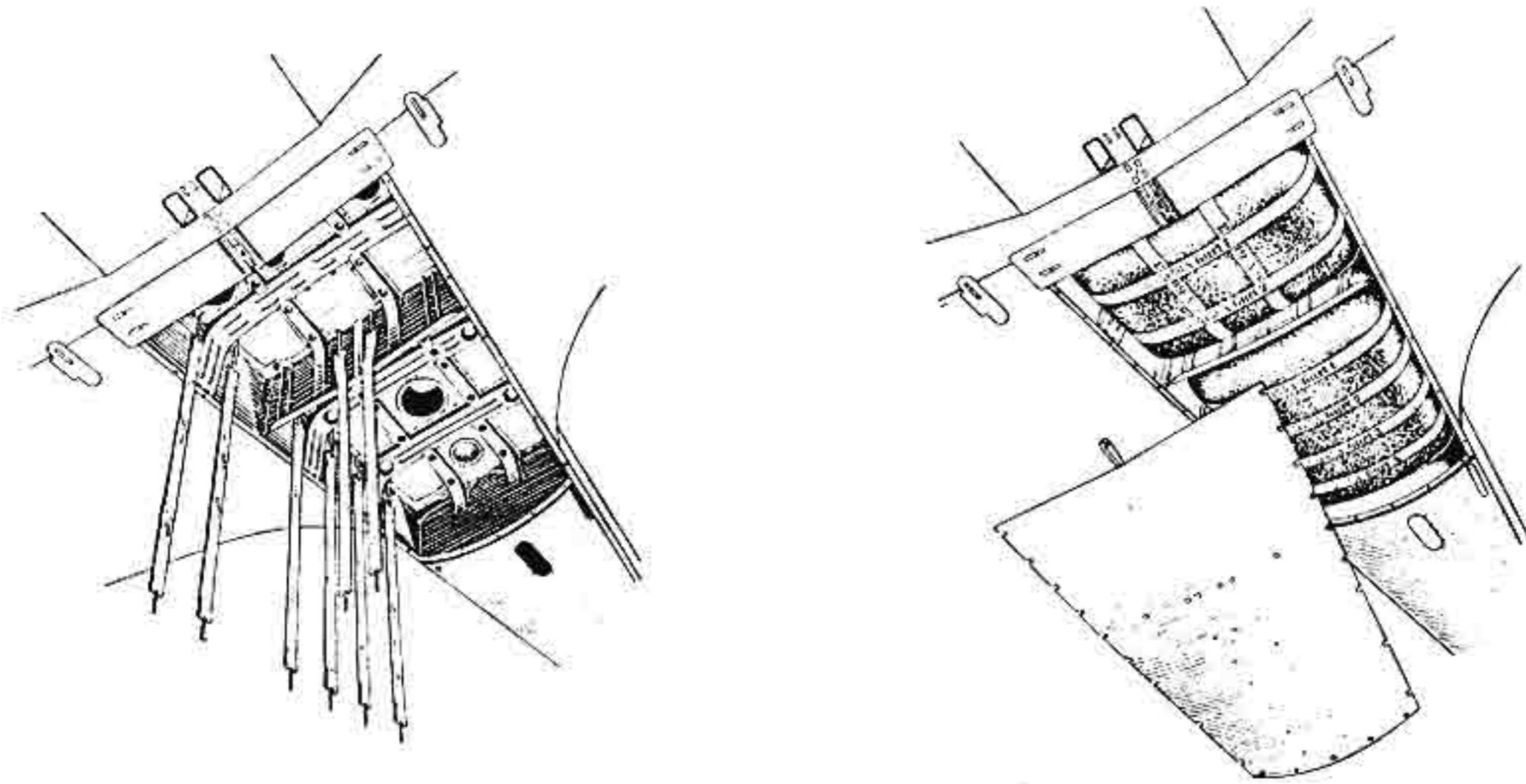

Fig. 12: Fuel tank compartment with fuel tanks removed and installed

- 1 Forward fuel tank
- 2 Rear fuel tank
- 3 Auxilliary tank
- 4 Drop tank
- 5 Primer fuel tank
- 6 Fuel tank filler point
- 7 Primer fuel filler point
- 8 Filler line
- 9 Overflow line
- 10 Ventilation line
- 11 Spill line
- 12 Fuel pump unit
- 13 Fuel line (tank to fuel valve)
- 14 Fuel valve
- 15 Fuel line (fuel valve to filter)
- 16 Filter
- 17 Fuel line (filter to fuel pump)
- 18 Engine fuel pump
- 19 Fuel line (fuel pump to injection pump)
- 20 Fuel injection pump
- 21 Bosch de-aerator
- 22 Fuel return flow valve (de-aerator to fuel pump)
- 23 Ventilation line (de-aerator to forward fuel tank)
- 24 Fuel pump spill line
- 25 Fuel line to cold-start mixing lever
- 26 Fuel feed lines connecting line
- 27 Cut-off valve
- 28 Rear tank fuel pump
- 29 Fuel transfer limit switch
- 30 Fuel line separation point
- 31 Fuel line (auxiliary tank to rear tank)
- 32 Air pressure line (supercharger to drop tank)
- 33 Excess pressure valve
- 34 Check valve
- 35 EP-TE fuel pump
- 36 ETC 501
- 37 Spacer bars

- 38 Auxilliary tank mounting bracket
- 39 SUW-primer pump
- 40 Primer fuel line
- 41 Circular feed line harness
- 42 Supercharger air pressure pipes
- 43 Fuel pressure measuring line
- 44 Fuel pressure gauge
- 45 Instrument panel bulkhead
- 46 Windscreen washer operation lever
- 47 Fuel line
- 48 Spray tubes
- 49 Windscreen
- 50 Bulkhead (firewall)
- 51 Bulkhead B

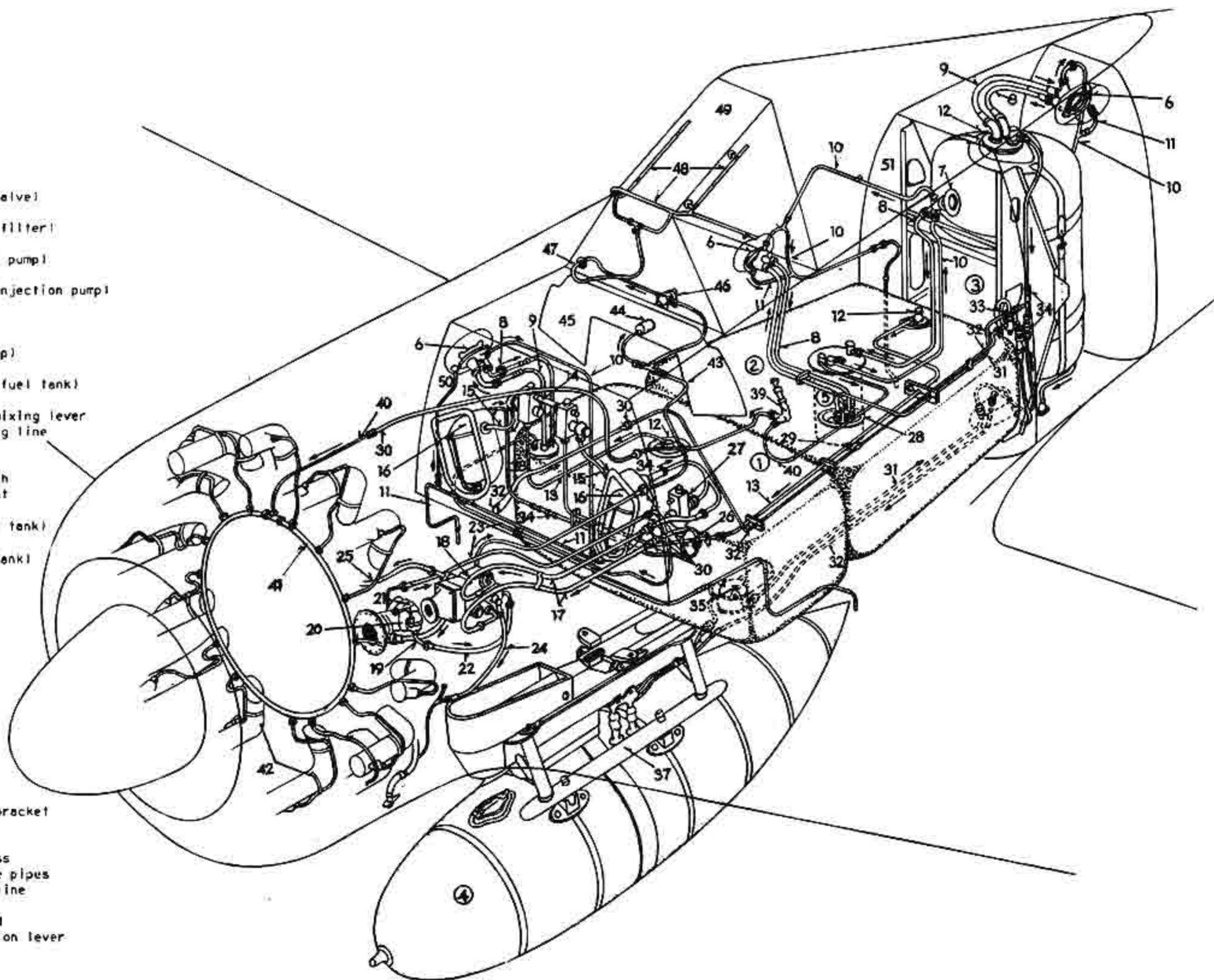

Fig. 13: Fuel system skematic



**D. (Luft) T. 2190 A-8**

**For Official Use Only!**

# **Fw 190 A-8**

**Aircraft Handbook**

**Part 8A**

**Armament installation**

**(Effective July 1944)**

**Issued September 1944**

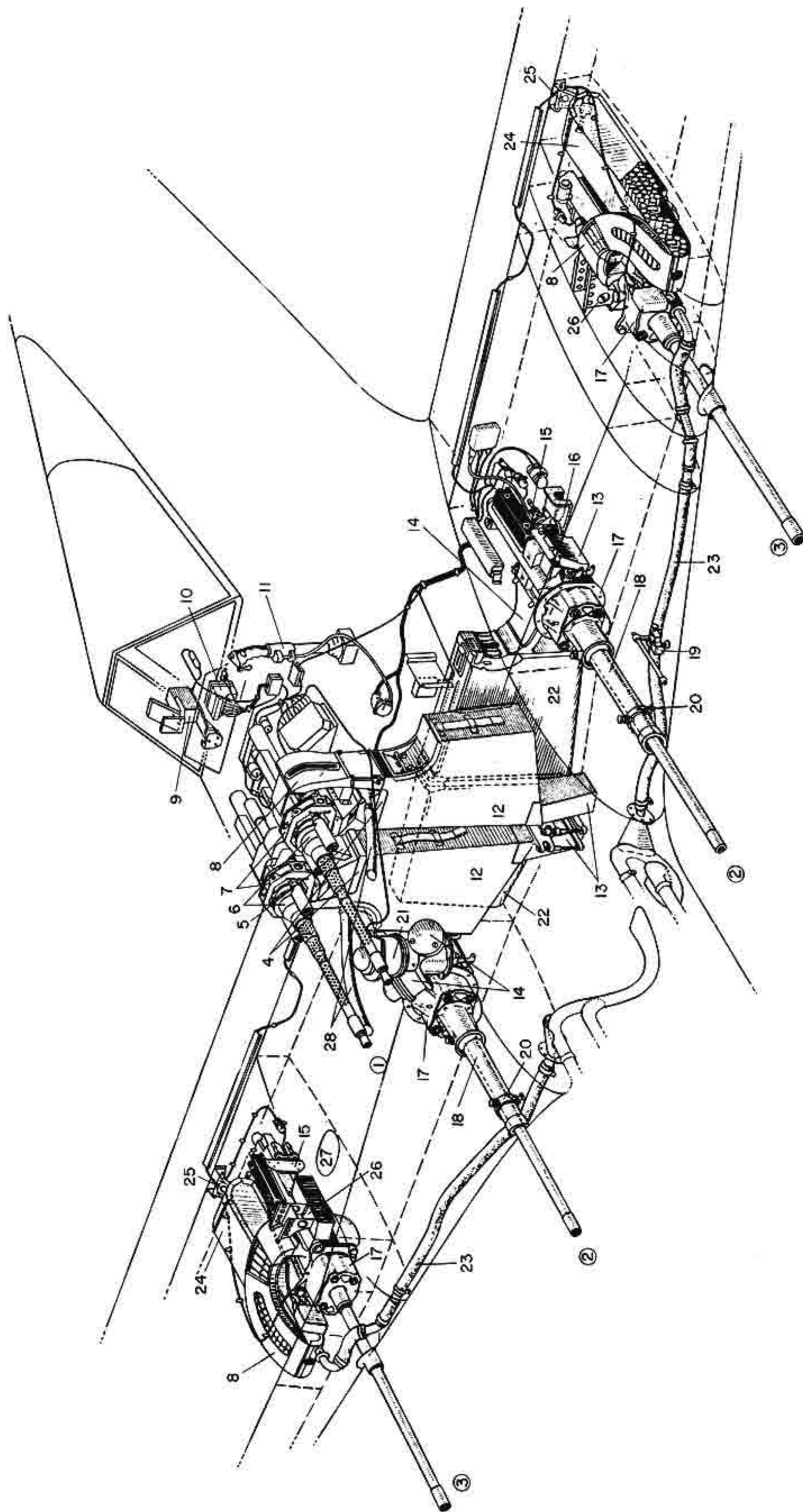

- |  |  |   |
|--|--|---|
| 1 Fuselage MG 131 13mm machine guns                              | 11 KG 13B control stick                                | 20 Barrel support clamp                                 |
| 2 Wing-root MG 151/20E 20mm cannons                              | 12 Fuselage weapons ammunition boxes (400 rounds each) | 21 Wing-root weapons synchronizing gear                 |
| 3 Outboard MG 151/20E 20mm cannons                               | 13 Link belt segment/cartridge casing discard chute    | 22 Wing-root weapons ammunition boxes (250 rounds each) |
| 4 Ammunition box attachment brackets                             | 14 Fuselage weapons synchronizing gear                 | 23 Hot air pipe for ammunition warming                  |
| 5 Link belt segment discard chute                                | 15 Adjustable rear mount                               | 24 Outboard weapons ammunition boxes (125 rounds each)  |
| 6 MG 131 forward mount   | 16 Rear mount support bracket                          | 25 Ammunition box rear suspension arm                   |
| 7 STL 131/5B weapon mount  | 17 Non-adjustable forward mount                        | 26 Mounting bracket & casing ejection chute             |
| 8 Ammunition feed chute  | 18 Cannon blast tube                                   | 27 Cartridge casing retrieval cover                     |
| 9 Revl 16B reflector gunsight                                    | 19 Armament collimation tube                           | 28 Cold air pipes for ammunition cooling                |
| 10 SZKK 4 armament switch --, round counter --, and control unit |  |   |

Fig. 1: System schematic

# I. Description

## A. General

The basic armament of the Fw 190A-8 consists of three groups of weapons. These are:

- 2 MG 131 machine guns in the fuselage upper cowling with 400 rounds per gun (1,1)
- 2 MG 151/20E cannons in the wing-roots, one per side, with 250 rounds per gun (1,2)
- 2 MG 151/20E cannons in the wings outboard of the propeller arc, one per side, with 125 rounds per gun (1,3)

All weapons are fired electrically, and use only E-type ammunition. The MG 131s and the wing-root MG 151/20Es are synchronized to fire through the propeller arc; the outboard MG 151/20Es are unsynchronized.

The positioning of the ammunition belts is indicated by a loading diagram on each ammunition box.

Cartridge casings and link-belt segments are—except for the casings of the outboard weapons—discarded.

The fuselage weapons are harmonized to a range of 400 m (435 yds); the wing mounted weapons, to a range of 550 m (600 yds).

The operating system for each weapons group is fully electrical and includes (inclusive of circuit breakers and electrical lines):

1. SVK 2-151/131E fuse and distributor box, and
2. EDSK-B1 gun cocking control box.

Each operating system is routed through the SZKK 4 switch, round counter, and control unit (1,10).

The fuselage and wing-root weapons are switched on by Switch I, the outboard weapons by Switch II (Switch I must first have been switched on). The outboard weapons must not be switched on less than 3 seconds after the other weapons. This interval will ensure that cocking of the fuselage and wing-root guns has been completed. As the aircraft battery can support the simultaneous cocking of a maximum of only four weapons, this action avoids the circuit overload that will otherwise result. A special instruction plate is fitted.

Two firing buttons, A and B1, are fitted on the KG 13B control column grip (1,11). The A-button fires the fuselage and wing-root weapons; the B1-button fires the outboard weapons.

ED-cocking units and EA-firing units are attached to each gun. The ED unit is utilized for automatic weapon cocking, breech-block position indication, and rounds counting; the EA unit, for weapon firing.

## B. Fuselage MG 131s

### 1. Weapon mounting

The first weapons group, two MG 131s, is positioned in the upper cowling, forward of the Windscreen mounting frame, in StL 131/5B fixed mountings (1,7).

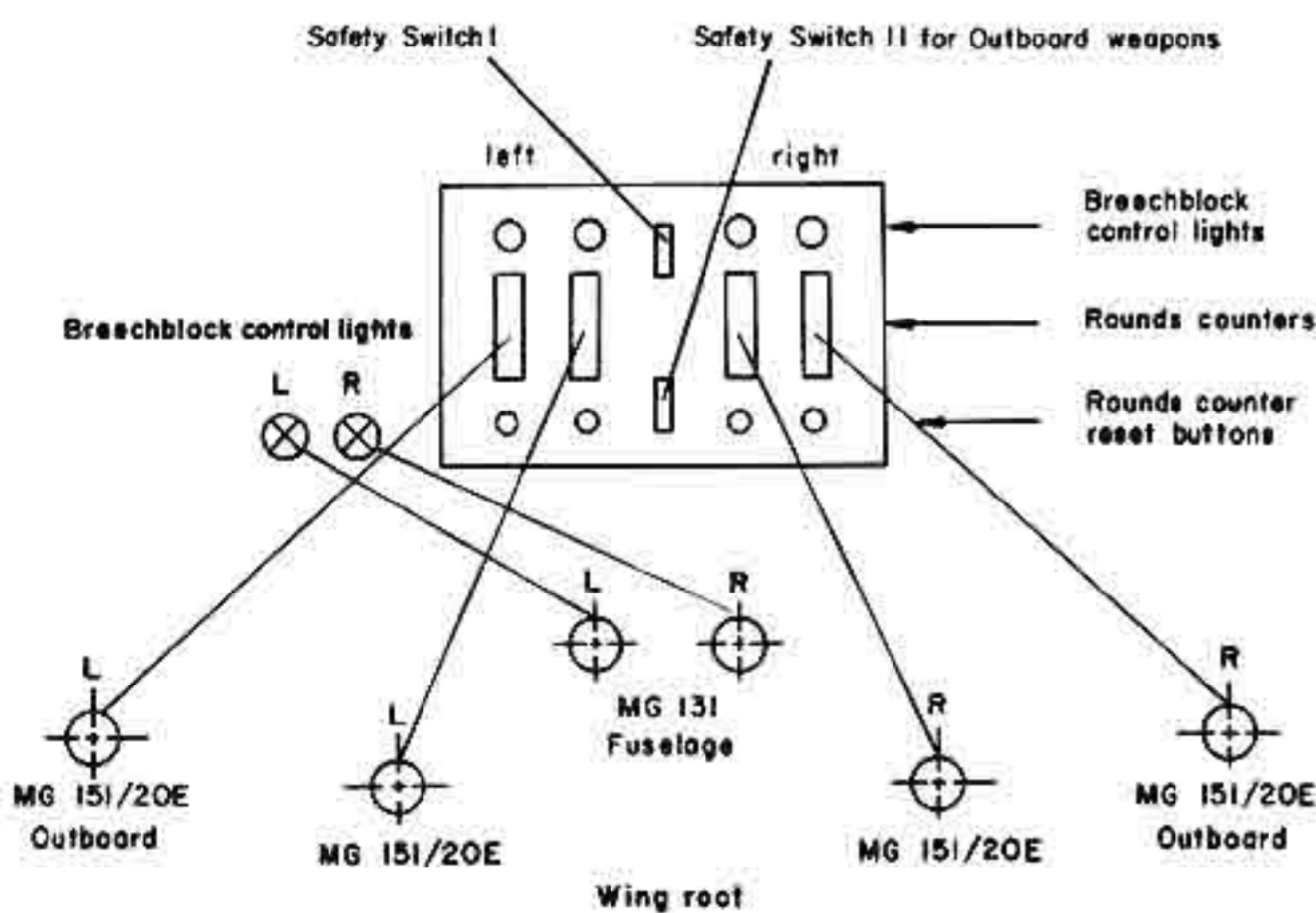
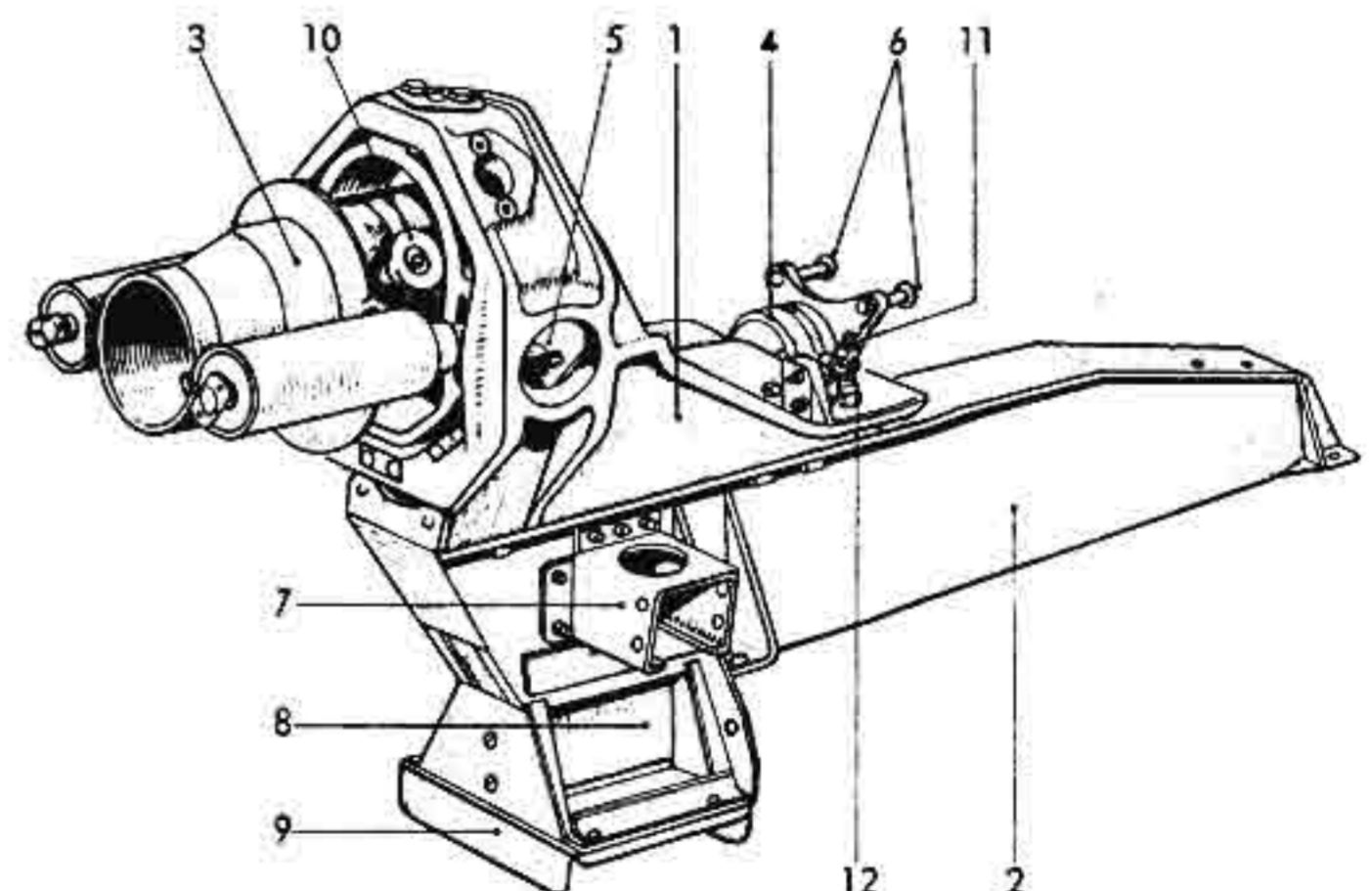

Fig. 2: SZKK-4



- |                              |                                     |
|------------------------------|-------------------------------------|
| 1 StL 131/5B weapon mount    | 7 Chute support brackets            |
| 2 Carrier bracket            | 8 Casing ejection chute             |
| 3 Forward support            | 9 Ammunition box attachment bracket |
| 4 Rear support               | 10 Locking pin                      |
| 5 Electrical contact plate   | 11 Horizontal adjustment screw      |
| 6 Rear support mounting pins | 12 Vertical adjustment screw        |

Fig. 3: Fuselage MG mount and carrier unit

The weapon mounts (3,1) are fixed to carrier brackets (3,2) which, in turn, are screwed to Bulkhead 1 and the Windscreen mounting frame.

The gun mount consists of a fixed forward support (3,3), an adjustable rear support (3,4), and a cast bearer. The forward support, into which the gun is locked, has a recoil fitting and can be rotated about its vertical and horizontal axes.

The rear support mounting pins (3,6) secure the MG 131 rear mounting bracket and lock the weapon into position; adjustable set screws permit vertical and horizontal adjustment of the weapon. The Cardan type suspension of the forward support permits precise alignment of the weapon.

The carrier bracket, of welded sheet steel construction, is attached to Bulkhead 1 and the Windscreen mounting frame. At its forward end it includes a cartridge casing ejection chute (3,8). To either side are screwed support brackets (3,7) for attaching the feed and ejection chutes. The ammunition box attachment bracket (3,9) is fastened beneath the cartridge casing ejection chute.

## 2. Ammunition stowage

Ammunition for the MG 131s is contained in two ammunition boxes (1,12), each of which can hold 400 rounds in a Type 131 disintegrating link belt.

The ammunition boxes (4,1) are positioned within the fuselage in front of the main spar and Bulkhead 1 in the area above the main wheel doors (4,2). At the

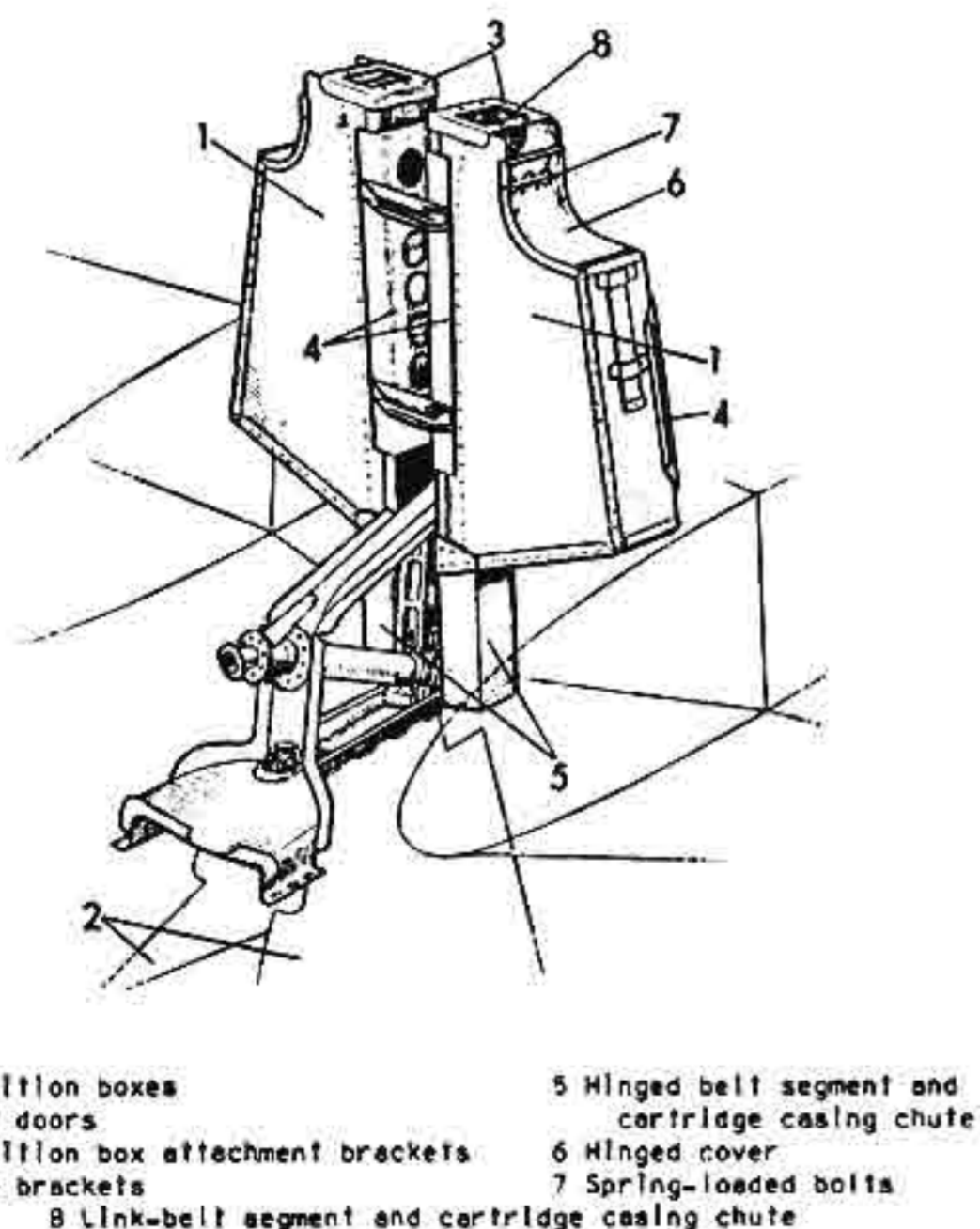

Fig. 4: Fuselage MG ammunition boxes

top, they are secured to attachment brackets (4,3), on the sides by guides (4,4), and at the bottom by hinged chutes (4,5). Each box has a hinged cover (4,6), which is locked by two spring-loaded bolts (4,7), through which the ammunition is loaded. They also each have an enclosed chute (4,8) through which the belt segments and cartridge casings drop into the slipstream. To improve ammunition storage, wooden supports are positioned on the floor of each box.

Ammunition in these boxes receives cooling air which is extracted from behind the engine cooling fan.

Two flexible pipes (5,1) on the underside of the centre cowling upper panel and two tubes (quick separation points!) (5,2) with terminal fittings (5,3) carry air to the ammunition boxes (5,4). To secure them, the terminal fittings are pushed rearward into the carrier brackets (5,5). The cooling air then circulates through the ammunition boxes.

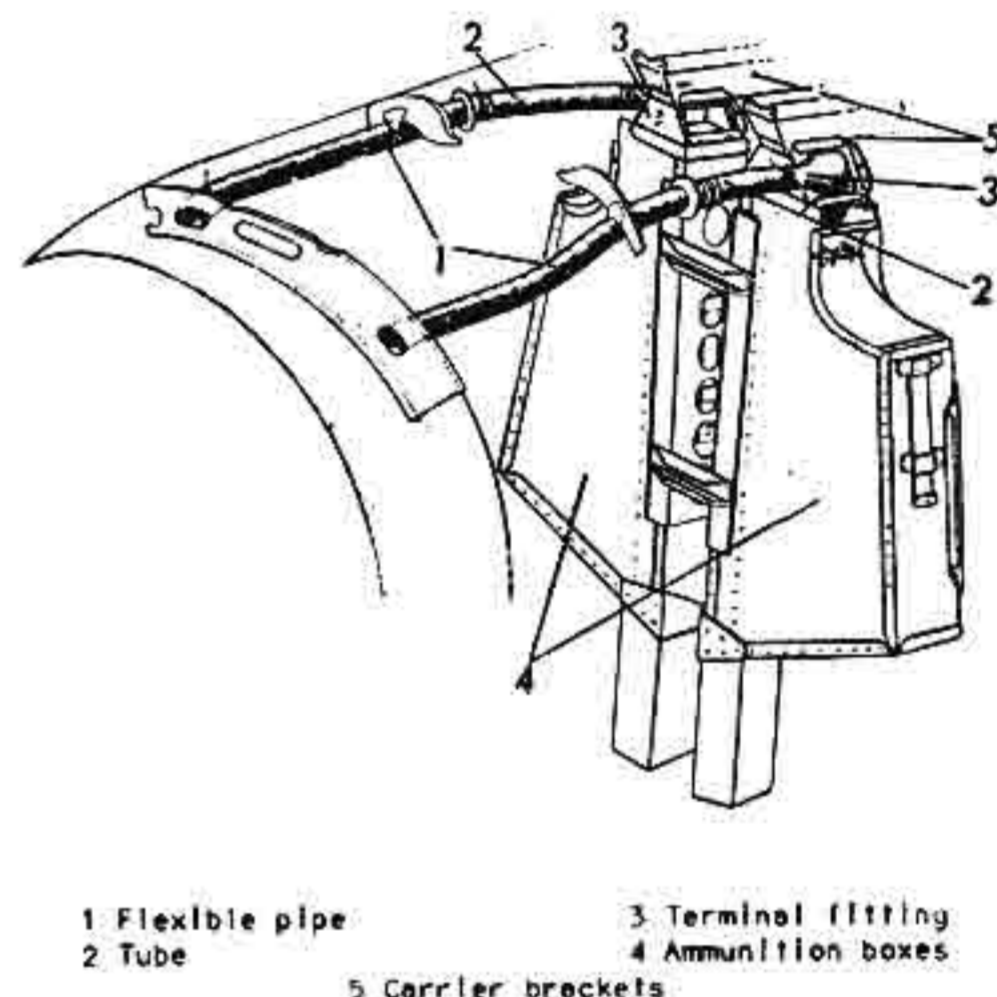

Fig. 5: Fuselage MG ammunition cooling

## 3. Ammunition feed chutes

The MG 131s are adapted for left as well as for right hand ammunition feed. This permits the respective feed chutes (6,1) to be positioned on the outboard sides of both MGs.

The cover (6,2), which removes to permit insertion of the ammunition belt, is held in place by studs (6,4), latches (6,3), and spring clips (6,5).

The link-belt segment discard chute (7,2) joins onto the cartridge casing ejection chute (7,3) which is mounted directly beneath each MG. The belt segments and casings drop out of the bottom of the fuselage through, in sequence, the above chutes, the ammunition box chute (7,5), and the hinged lower chute (7,7).

### C. Wing-root MG 151/20Es

#### 1. Weapon mounting

Two wing-root MG 151/20E cannons comprise the second group of weapons. Each gun is secured in an StL 151/2B fixed weapon mount; which consists of a forward and a rear support. The forward support (1,17) provides the recoil housing and the forward attachment point for the weapon; the rear support (1,15), the alignment adjustment mechanism and rear attachment point. Both supports are attached to the wing; the front one to the main spar, the rear one to a fitting between Centre ribs 1 and 3.

The cannon barrel is housed within a blast tube (1,18) which is secured to the forward support and to the wing leading edge.

To steady its barrel, the cannon is fitted with a clamp (1,20)—a three piece ring with set screws and lock nuts. In the blast tube are 3 holes through which the set screws pass.

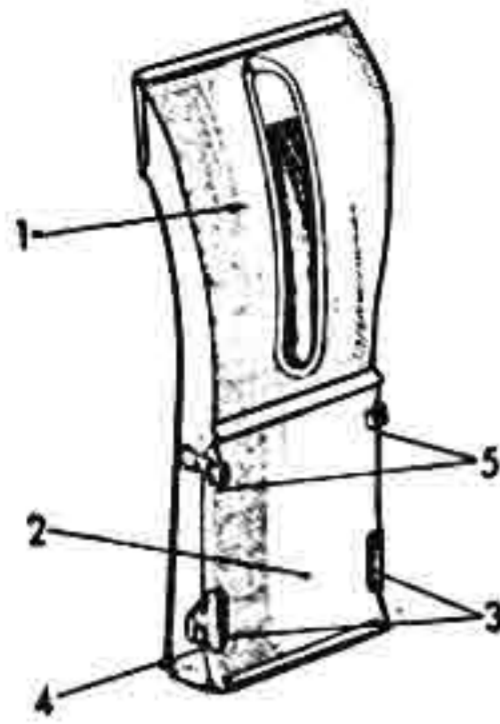

1 Ammunition feed chute  
2 Cover plate  
3 Latch  
4 Studs  
5 Spring clips

Fig. 6: Fuselage MG ammunition feed chute

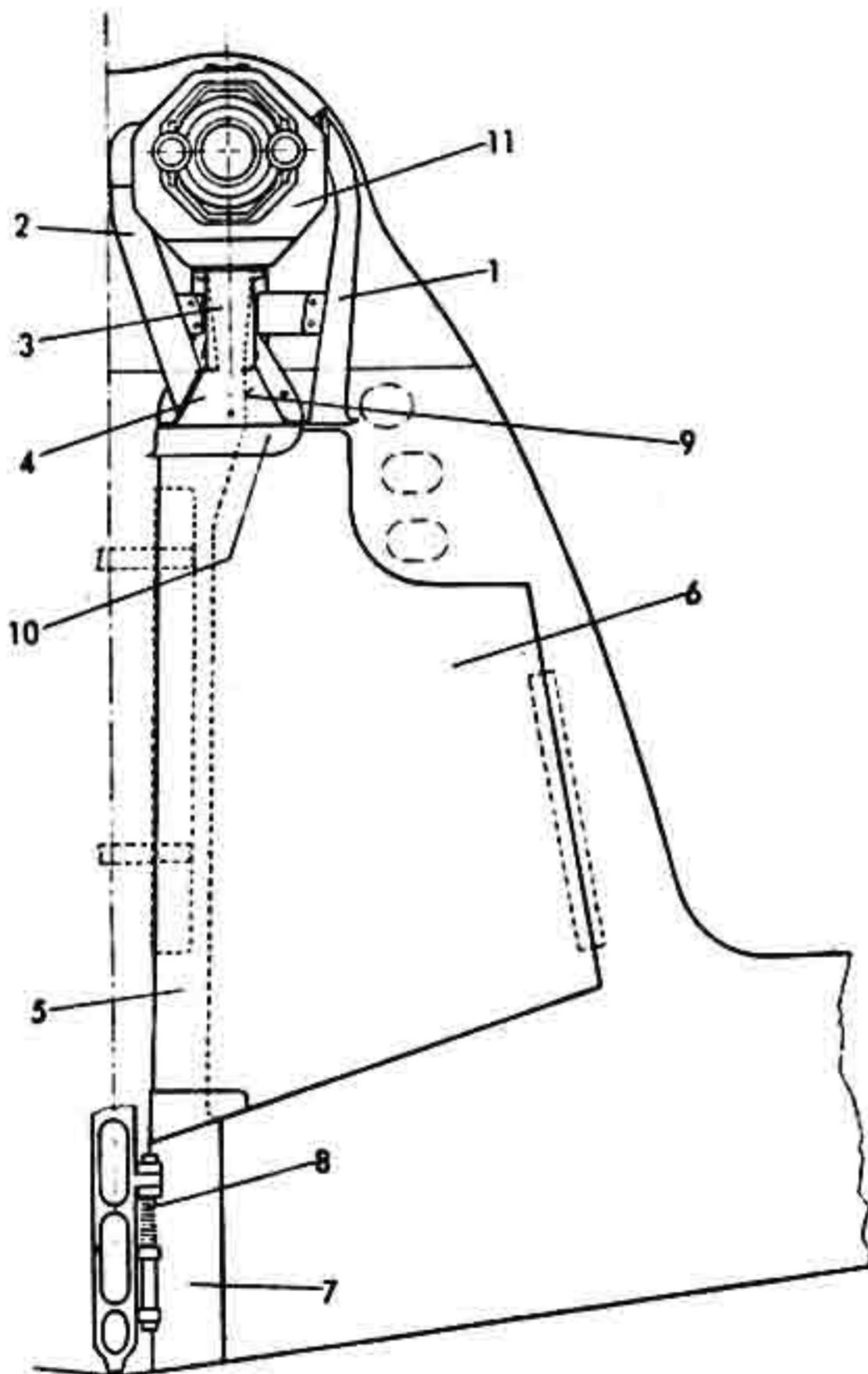

1 Ammunition feed chute  
2 Link-belt segment discard chute  
3 Cartridge casing ejection chute  
4 Weapon carrier bracket  
5 Enclosed belt segment and cartridge casing chute  
6 Ammunition box  
7 Hinged discard chute  
8 Hinge pin with spiral spring  
9 Cartridge casing chute side plate  
10 Ammunition box attachment bracket  
11 StL 151/2B weapon mount

Fig. 7: Fuselage MG ammunition feed and discard chutes (Seen from the front)

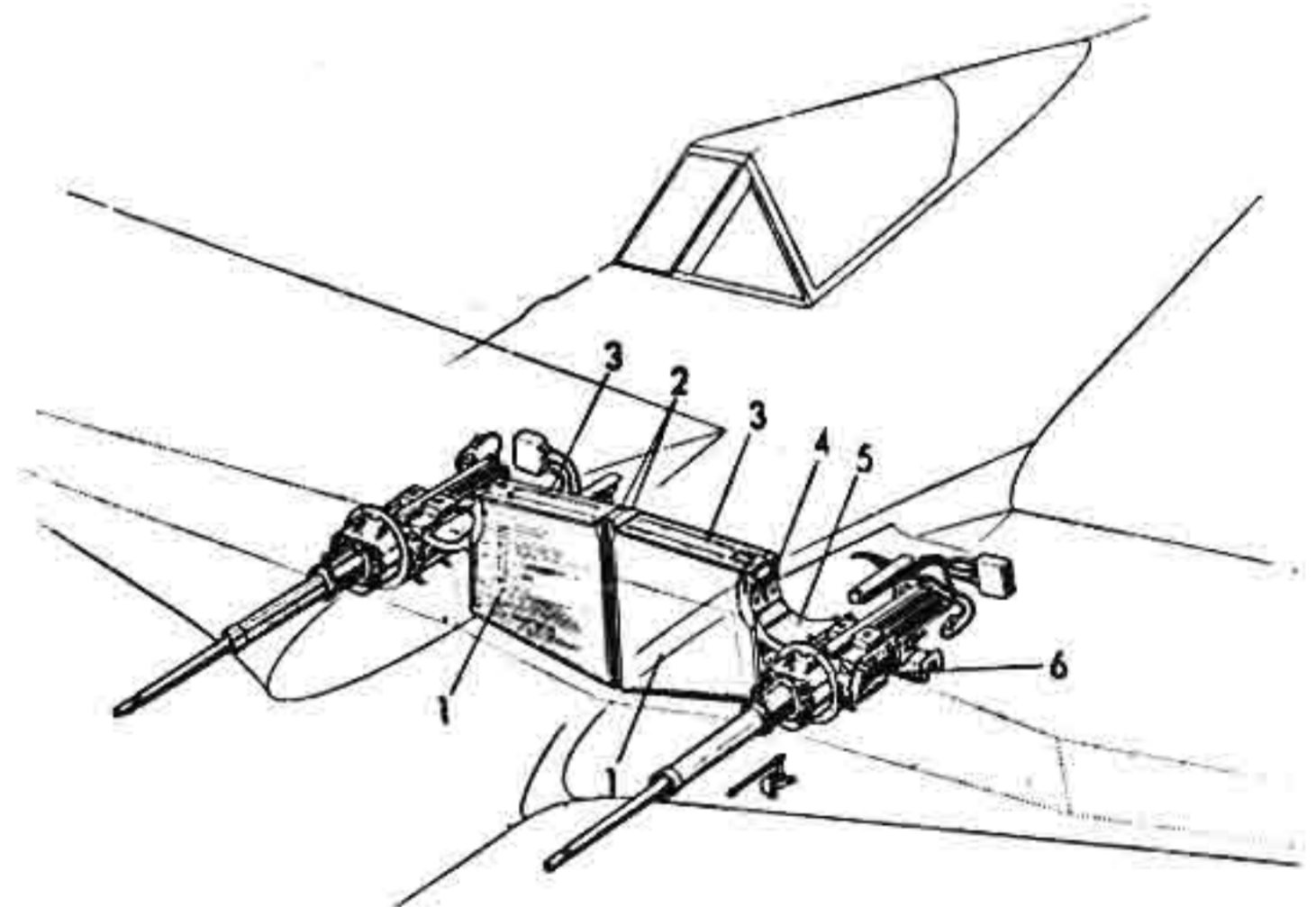

1 Ammunition boxes  
2 Hose fitting  
3 Hinged door  
4 Lock  
5 Feed chute  
6 Discard chute

Fig. 8: Wing-root cannon layout

#### 2. Ammunition stowage

The ammunition boxes for the two MG 151/20Es are positioned within the fuselage behind the main spar. They are accessible through the fuselage bottom via two hinged doors.

Each ammunition box (8,1) is hooked onto the fuselage centre support by its nose fitting (8,2); guide fittings give sideways support, and the access doors give vertical support.

In the throat of each ammunition box is a roller over which the ammunition belt moves as it leaves the box.

A wedge shaped divider piece is built into each ammunition box to improve the efficiency of the ammunition feed.

A hinged door (8,3) on the top of each box opens to give access to the box and permit loading of the ammunition belt.

### 3. Ammunition feed chutes

To permit direct feeding of the ammunition, the MG 151/20Es are both rigged for inboard feed, i.e. the left weapon has right side feed, etc. Ammunition is fed to the guns through ammunition feed chutes (Fig. 9).

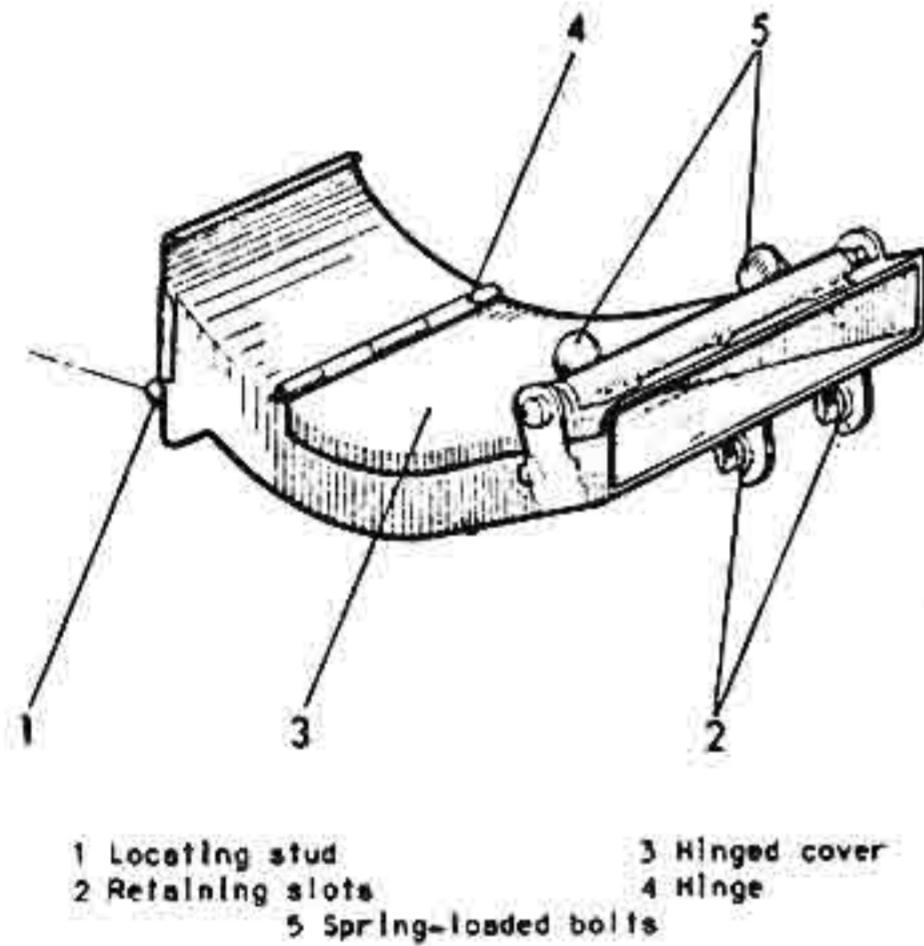

1 Locating stud  
2 Retaining slots  
3 Hinged cover  
4 Hinge  
5 Spring-loaded bolts

Fig. 9: Left gun feed chute

The ammunition feed chute is attached to the ammunition box by two studs (9,1) and is secured at its outboard end to the belt link and cartridge disposal chute. The two semi-circular retaining slots (9,2) rest on a shaft to which they are secured. A hinged cover (9,3), locked by two spring-loaded bolts (8,5), gives access to the chute.

The link-belt segments are ejected from the outboard side of each weapon through a combined link-belt disposal chute (10,1) and cartridge casing ejection chute (10,2); the latter positioned directly beneath the gun. Both are screwed to the wing lower skin.

To aid in loading the ammunition belt into the gun, a flap (10,3) on the upper portion of the chute can be opened. A slotted shaft (10,7) fitted into the outrigger bracket (10,6) secures the ammunition feed chute (Fig. 9). With both units in position, the

shaft (10,7) is pressed in against the force of the spring (10,9); permitting the feed chute slots (9,2) to drop down over the notches. The shaft is now released and the slots are locked into place.

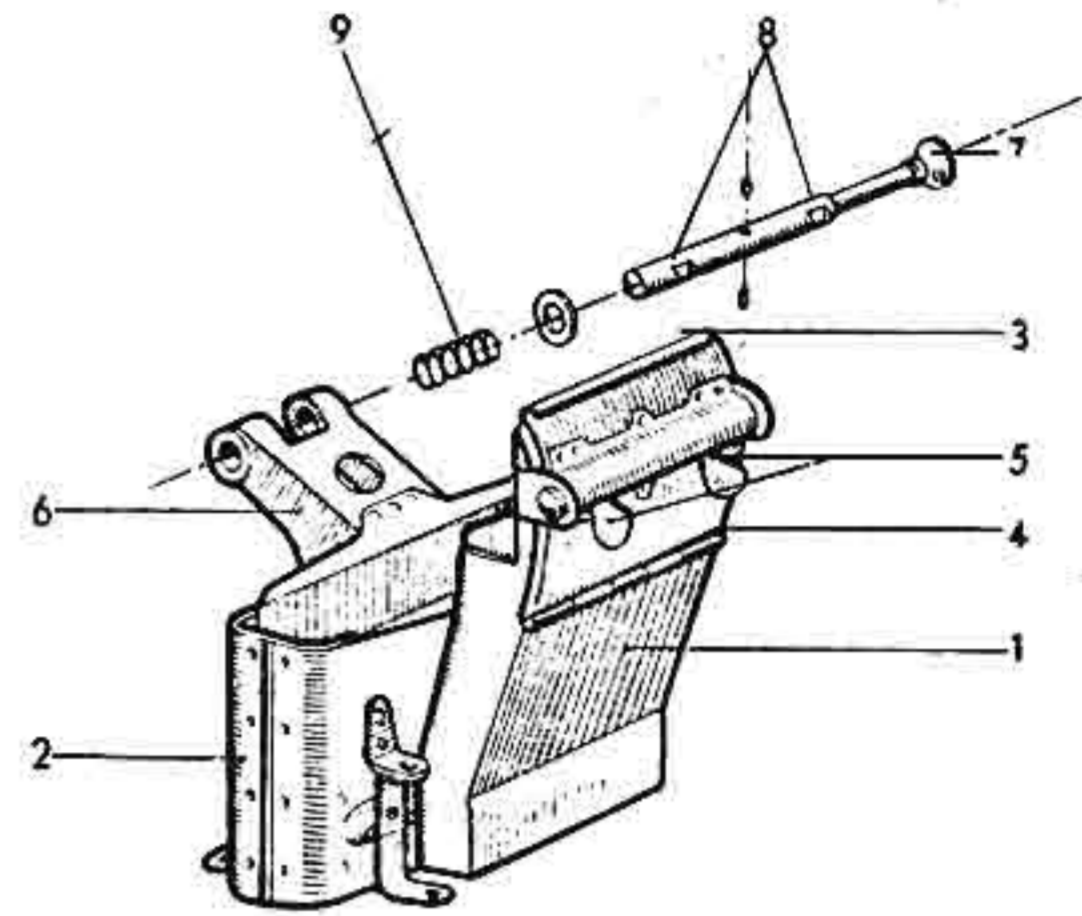

1 Link-belt disposal chute  
2 Cartridge casing ejection chute  
3 Hinged flap  
4 Hinge  
5 Spring-loaded bolts  
6 Outrigger brackets  
7 Feed chute locking shaft  
8 Notches  
9 Spring

Fig. 10: Left MG link and cartridge disposal chute

## D. Outboard MG 151/20Es

### 1. Weapon mounting

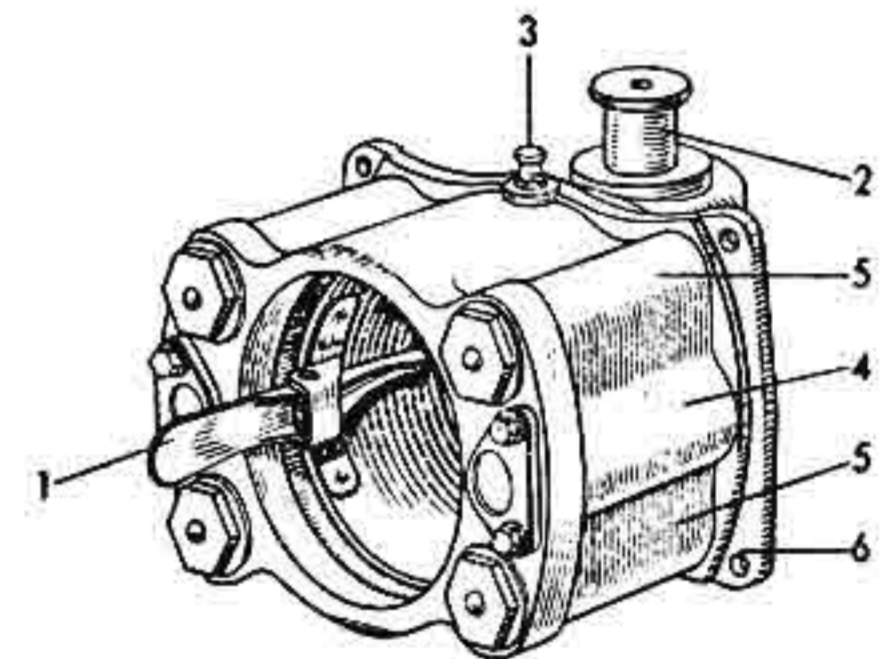

1 Barrel release lever  
2 Locking pin  
3 Grease nipple  
4 Damping cylinder  
5 Spring cylinder  
6 Attachment flange

Fig. 11: Outboard cannon forward support

The third weapons group consists of two MG 151/20E cannons, located in the left and right wing panels outside the propeller arc. Each weapon is secured in an StL 151/11 fixed mount, which consists of a forward and rear support. The guns are positioned on

their sides to facilitate ammunition feeding. The forward support houses the weapon trunnions; the rear support secures the weapon rear attachment points.

The forward support is attached to a bracket which is, in turn, secured to the wing lower shell between Centre ribs 7 and 8.

To reduce the weapon firing shock, a recoil unit (11,4 & 5) is fitted within the forward support.

The rear, adjustable, mount is fixed to a mounting bracket which is, in turn, secured to Centre rib 7. The weapon can be adjusted to  $\pm 1^\circ$  vertically and horizontally, and can be removed without affecting its adjustment.

## 2. Ammunition stowage

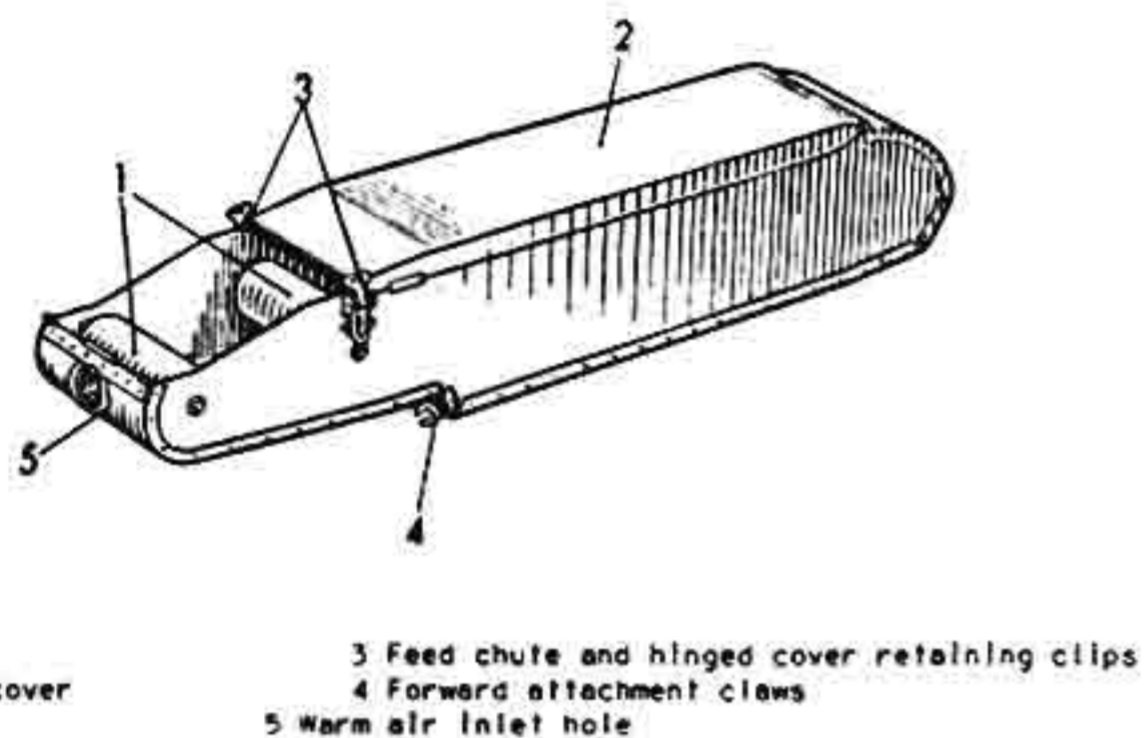

1 Rollers  
2 Hinged cover  
3 Feed chute and hinged cover retaining clips  
4 Forward attachment claws  
5 Warm air inlet hole

Fig. 12: Outboard gun ammunition box

The ammunition boxes (1,24), each of which can hold up to 125 cartridges in a Type 151 ammunition belt, are mounted parallel to, and outboard of, their respective weapons, between Centre ribs 8 and 9. The MG 151/20E mounted in the left wing has right hand feed; the one in the right wing, left hand feed.

The front end of the ammunition box is secured to the forward rim of the gun bay aperture by a spring-loaded bolt assembly which grips the two suspension claws (12,4). At the back it is secured by a spring-loaded bolt which slides through a fitting at the lower rear edge of the ammunition box. The bolt assembly is retained within a hinged mounting arm which is, in turn, fixed to the rear spar.

A wooden strip is placed in the ammunition box to keep the belt as nearly horizontal as possible. In addition, there are two horizontal rollers to aid ammunition feeding. At the top is a hinged cover (12,2) which opens to permit loading of the ammunition belt. Two catches (12,3), riveted to the sides of the box, lock the cover and secure the ammunition feed chute to the box. Warm air for ammunition warming enters through an opening (12,5) in the front of the box.

## 3. Ammunition feed chutes

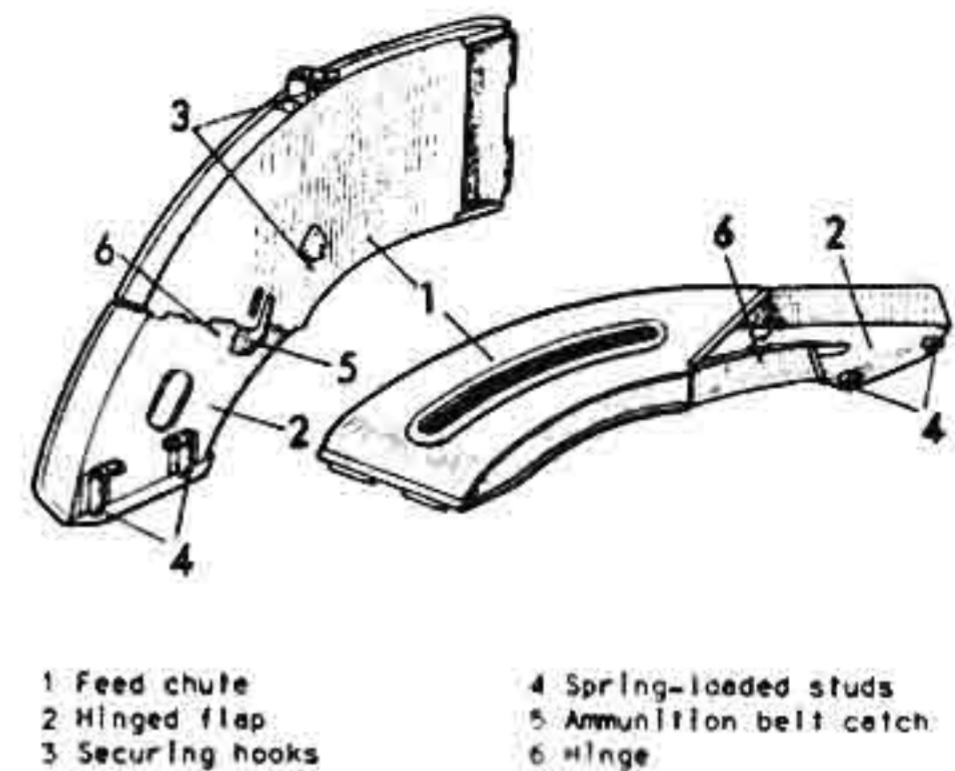

1 Feed chute  
2 Hinged flap  
3 Securing hooks  
4 Spring-loaded studs  
5 Ammunition belt catch  
6 Hinge

Fig. 13: Outboard cannon ammunition feed chute

The ammunition belt is fed to the gun through a feed chute (Fig. 13) and an ammunition lead-in section (14,1).

The hinged feed chute, comprising a chute (13,1) and a hinged flap (13,2), is secured to the ammunition box by a hinge assembly and by two hooks (13,3).

The hinged flap, which is open at the top, has two spring-loaded studs (13,4) which are inserted into matching holes in the ammunition lead-in section. A catch (13,5), riveted to the bottom of the flap, prevents ammunition belt movement when the flap is open.

The ammunition lead-in section (14,1) is riveted to a bracket (14,2) which also secures the cartridge casing ejection chute (14,3). The bracket is attached to Centre rib 7.

The casing ejection chute has a spring steel barrier (14,4) which prevents the return of ejected casings to the weapon, thus avoiding the possibility of a firing stoppage. The casings are expelled into the area between Centre ribs 6 and 7; from there they are removed through a hand hole in the wing lower skin. Additional sheet metal is fitted around the area to prevent structural damage by the ejected casings.

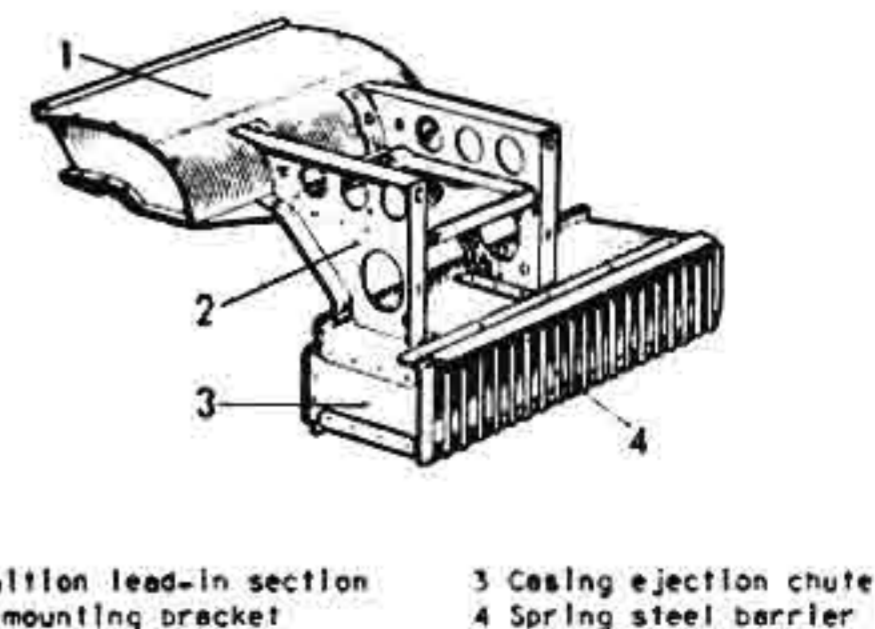

1 Ammunition lead-in section  
2 Unit mounting bracket  
3 Casing ejection chute  
4 Spring steel barrier

Fig. 14: Outboard cannon ammunition lead-in section and cartridge casing ejection chute



The link segment disposal chute is riveted to the weapons bay cover door, and guides the ejected link segments from the cannon into the slipstream. When the cover door is locked, the link segment chute must not touch the gun.

#### 4. Ammunition warming

The outboard weapon ammunition boxes are heated by warm air which is drawn from the exhaust pipes for Cylinders 5 and 10. The air flows through a pipe (1,23) within the wing leading edge and then through an opening in the forward end of each ammunition box.

### E. Gunsight

The weapons are aimed by a Revi 16B (1,9) optical sight which is fixed to the Windscreen mounting frame behind a bullet resistant glass panel 50 mm thick and set at an angle of  $25^\circ$ . The shallow slope of the windscreen ensures that the reflection of the sighting image is not visible to the pilot. The field of view downwards is  $3^\circ$ .

The gunsight base plate is fixed to the support bracket (15,1); and, the mounting unit (15,2) is fixed to the Windscreen mounting frame. The bracket and mounting unit are joined by hexagonal screws (15,5) and spherical washers (15,7). The spherical shape of the bearing-surface area between the two units permits precise adjustment of the reflector sight.

The gunsight is connected into the aircraft power supply by depression of the appropriate circuit breaker on the right instrument console.

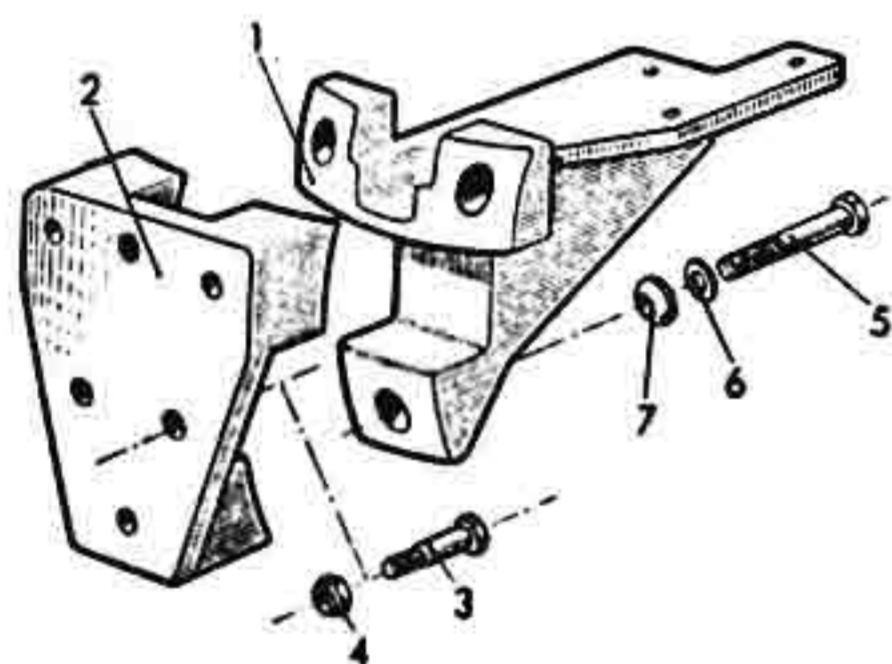

- |                    |                    |
|--------------------|--------------------|
| 1 Support bracket  | 4 Nuts             |
| 2 Mounting unit    | 5 Hexagonal screws |
| 3 Hexagonal screws | 6 Washer           |
| 7 Spherical washer |                    |

Fig. 15: Gunsight mounting assembly

### F. Collimation tube

The installation location of the collimation tube is shown in Fig. 1-19. Its distance from the fuselage centre-line is 1220 mm.

The tube sighting hole in the wing leading edge is taped over when not in use.

The collimation tube securing nut (16,1) is secured in a spherical support in the wing leading edge; the mounting bracket (16,3) is attached to the rear wall of the leading edge panel. The collimation tube (16,2) is joined to the mounting bracket (16,3) by a connector segment (16,4) and adjustment bracket. The tube can be aligned vertically and horizontally by two set screws (16,6 & 7); the settings being maintained by locknuts (16,8).

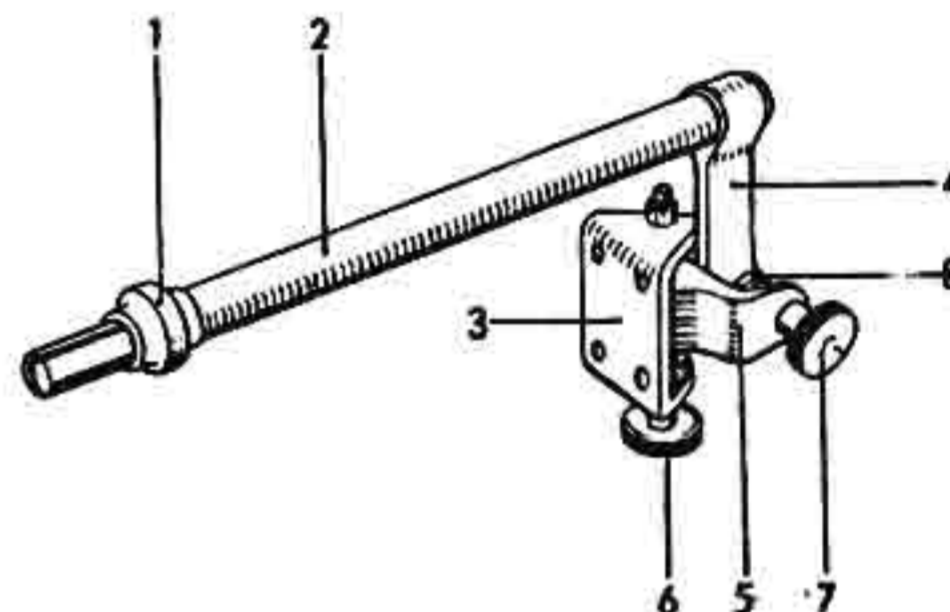

- |                     |                               |
|---------------------|-------------------------------|
| 1 Tube securing nut | 5 Adjustment bracket          |
| 2 Collimation tube  | 6 Vertical adjustment screw   |
| 3 Mounting bracket  | 7 Horizontal adjustment screw |
| 4 Connector segment | 8 Locknuts                    |

Fig. 16: Collimation tube

## II. Installation and removal

For removal, the weapons must be uncocked and locked. All installation and removal work can be carried out with the aircraft in the tail down position.

### A. Fuselage MG 131s

#### Removal:

- 1) Open the fuselage side panels and the fuselage armament cover.
- 2) Withdraw the weapon actuation cable from the EDSK-B1 distributor box and the firing cable from its socket.
- 3) Pull out the forward support locking pin and rotate it leftward to the stop.
- 4) Pull the weapon rearward until its rear guide bushings are free of the rear mount guide pins.
- 5) Swing the rear of the weapon upwards and withdraw it from the forward support.

#### Installation:

For installation, the sequence is reversed.

### B. Wing-root MG 151/20Es

#### Removal:

- 1) Open wing-root armament doors.
- 2) Withdraw the firing cable from the electrical circuit terminal board, and the weapon actuation cable from the EDSK-B1 distributor box.
- 3) Remove bolt cover.
- 4) Open and remove the barrel support clamp (Weapon is now no longer adjusted!).
- 5) Depress the barrel release lever. Rotate barrel 1/6th turn to the left and withdraw it.
- 6) Release the weapon from the forward support (Pull out locking pin and rotate 90°) and withdraw rearwards. Simultaneously, depress the spring-loaded keys in the guide pins of the rear support.

#### Installation:

Reverse the sequence of the above procedure.

### C. Outboard MG 151/20Es

#### Removal:

- 1) Open weapons bay cover door.
- 2) Remove ammunition box.
- 3) Unscrew the weapon actuation cable from the EDSK-B1 distribution box.
- 4) Remove bolt cover. The gun must not be cocked and the breechblock must be in the safetied position.
- 5) To withdraw the barrel forward, depress the barrel release lever:
  - a) Either from the weapons bay, by reaching forward beyond the forward mount and pressing the lever; whereby a second person removes the barrel; or,
  - b) From the wing lower surface through a 10 mm diameter hole with a screw driver, directing it toward the fuselage.
- 6) Remove the firing cable from its socket.
- 7) Unlock the gun from its forward support. For that, pull out the locking pin and rotate it left to the stop. Press the spring-loaded keys in the guide pins and withdraw the weapon rearwards.

#### Installation:

Installation reverses the above procedure.

### D. Fuselage weapons ammunition boxes

When the underfuselage ETC rack is installed, the removal of these boxes is not possible directly. Under these circumstances, the ETC carrier must first be swung down.

Remove the wheel fairing plates.

Rotate the cartridge casing and link segment chutes forward and withdraw the ammunition boxes downward.

Installation reverses the above procedures.

### E. Wing-root weapons ammunition boxes

The removal and installation of the ammunition boxes presents no difficulties. Hinged doors secure the boxes against shifting and falling out.

## F. Outboard weapons ammunition boxes

### Removal:

Open the weapons bay cover door.

The ammunition feed chute hinged flap is unlocked and lowered.

First release the ammunition box from the rear suspension point, then from the forward one. Lift the forward end of the ammunition box slightly; this frees the forked fitting from the spring-loaded bolt. Slant the box downward for removal rearwards.

Installation is reversed.

## III. Weapons testing

Before an aircraft undertakes any operational missions, its weapons must be harmonized and a functional test carried out.

- 1) The aircraft must be trestled and restrained, and be pointing into the butts.
- 2) Mount the calibrated, rotating disk. Carry out synchronization firing point inspection (Reference point is 1/3 blade width in front of the propeller trailing edge); also complete a firing circuit continuity check.
- 3) First, carry out a synchronization test on the MG 131s and the wing-root MG 151/20Es. Fire 21 rounds per gun.  
Ensure that the belt links separate properly. Verify the operation of the rounds counters for the MG 151/20Es.  
The synchronization test pattern (airscrew without compensating weights fitted) is fired at an engine speed of 1800 rpm. Propeller control: 'Manual' position, takeoff setting (fine pitch).
- 4) To compute synchronization operating tolerances for the MG 131s, use the following values:  
Muzzle velocity = 750 m/sec (2460 fps)  
Round advance time = 0,003 sec  
Airscrew reduction gearing = 1,84:1  
Weapon radius = 685 mm (26.6 in)  
  
For computation of synchronization operating tolerances for the wing-root MG 151/20Es, use the following values:  
Muzzle velocity = 705 m/sec (2310 fps)  
Round advance time = 0,005 sec  
Airscrew reduction gearing = 1,84:1  
Weapon radius = 980 mm (38.6 in)
- 5) The computed tolerance figures can be exceeded by 4%. Permitted firing pattern dispersion: 20% of the computed tolerances.
- 6) For synchronization test firing, a calibration disk with the predicted impact area cut out, can be used.  
The synchronization firing pattern for aircraft with compensating weights fitted is verified without the calibration disk fitted. Propeller

control: Takeoff setting (fine pitch) at 2400 rpm.

During functional testing no jams are allowed, otherwise repeat the test.

- 7) The aircraft is levelled in accordance with its bench marks.
- 8) The target (Annex 1) is positioned vertically, with its height set in relation to the collimation tube.  
The collimation tube is sighted on the aiming cross designated for it. For this, the tube must previously have been levelled.
- 9) The weapons are so adjusted that the centre of the firing pattern lies in the centre of the aiming cross.
- 10) The Revi gunsight must be sighted on the appropriate aiming point.
- 11) The shot pattern for the MG 131s must be fired at one time (21 rounds per gun).  
Maximum spread for 100% of the hits:  
Height = 100cm    Width = 80cm at 100m range  
  
Shot spread for the wing-root MG 151/20Es (21 rounds per gun):  
Height = 70cm    Width = 60cm at 100m range  
Height = 35cm    Width = 30cm at 50m range  
  
Shot spread for the outboard MG 151/20Es (21 rounds per gun):  
Height = 70cm    Width = 80cm at 100m range  
Height = 35cm    Width = 40cm at 50m range
- 12) Immediately after test firing, the adjustment screws for all weapons and the gunsight must be locked in place.
- 13) Test firing can take place immediately before commencement of flying, so long as the aircraft has already been completely prepared and ground checked, and the functioning and adjustment of the weapons system is not affected by subsequent maintenance on the aircraft.

## IV. Adjustment

### A. General

The alignment of the weapons is as shown in Annex A. The gunsight sighting line is adjusted to focus on the sighting triangle of the target sheet, thus placing it parallel to the aircraft longitudinal axis.

### B. Adjustment procedure

Carry out adjustments in accordance with L.Dv.4/7.

The target (Annex B) is positioned at 100 m (in exceptional circumstances 50 m) distance and is placed vertically.

Insert the collimator in the collimation tube and adjust the target to the appropriate height.

Test firing of the MG 131s is carried out using Type Ub. E. 13 mm high-explosive ammunition; of the MG 151/20Es, using Type Ub.151 20 mm high-explosive ammunition, without the Type E self-destroying fuse (115 g ammunition).

For weapon adjustment, remember the following:

Before commencing adjustment, loosen the set screws on the mount rear supports. Adjustments can now be made to these screws. The vertical and horizontal adjustment screws of each weapon are easily accessible.

In order to adjust the gunsight, the instrument panel cowling must first be removed.

All connections which were loosened during this operation must now be retightened and secured.

After completing all adjustments, remove all tools from the aircraft.

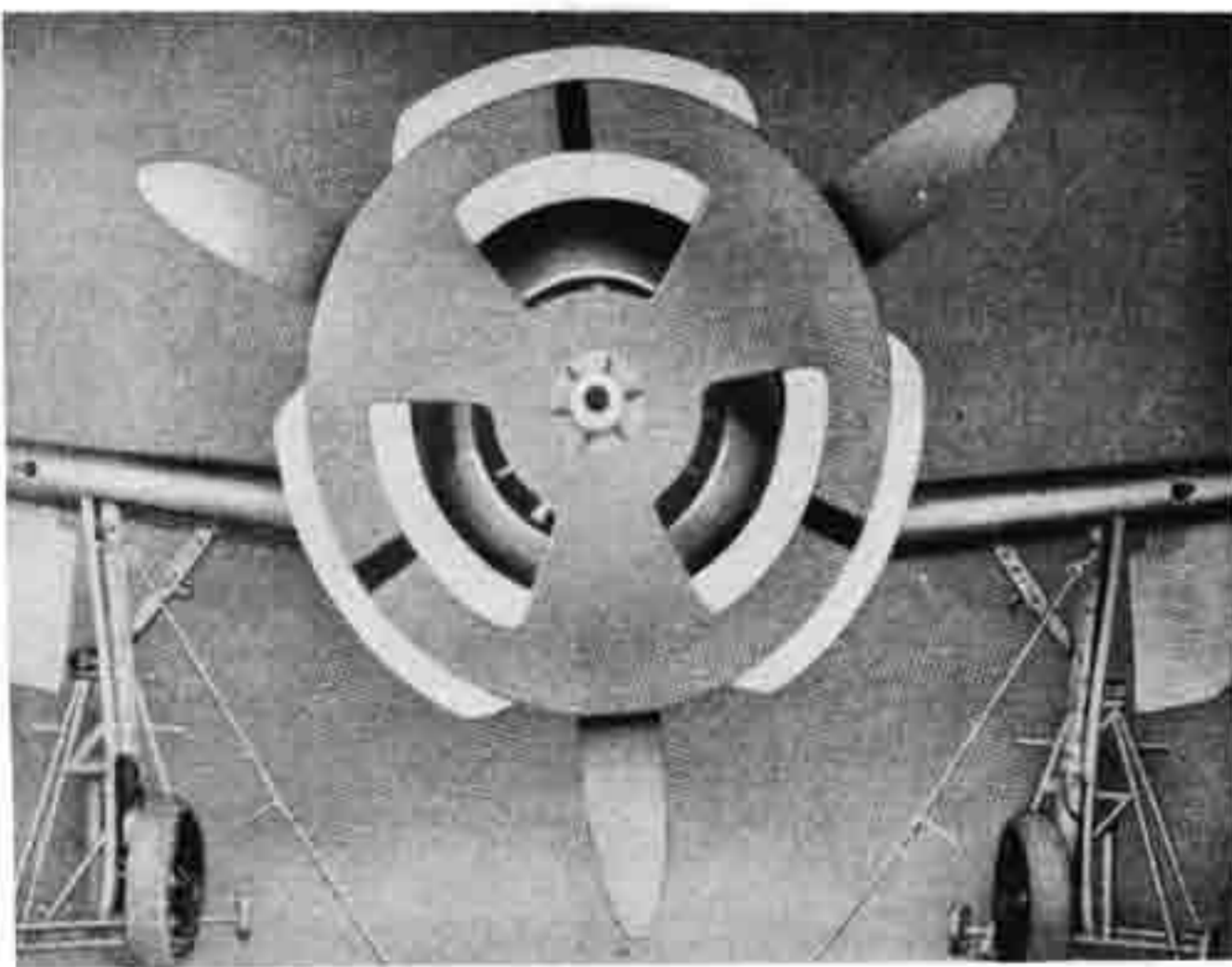
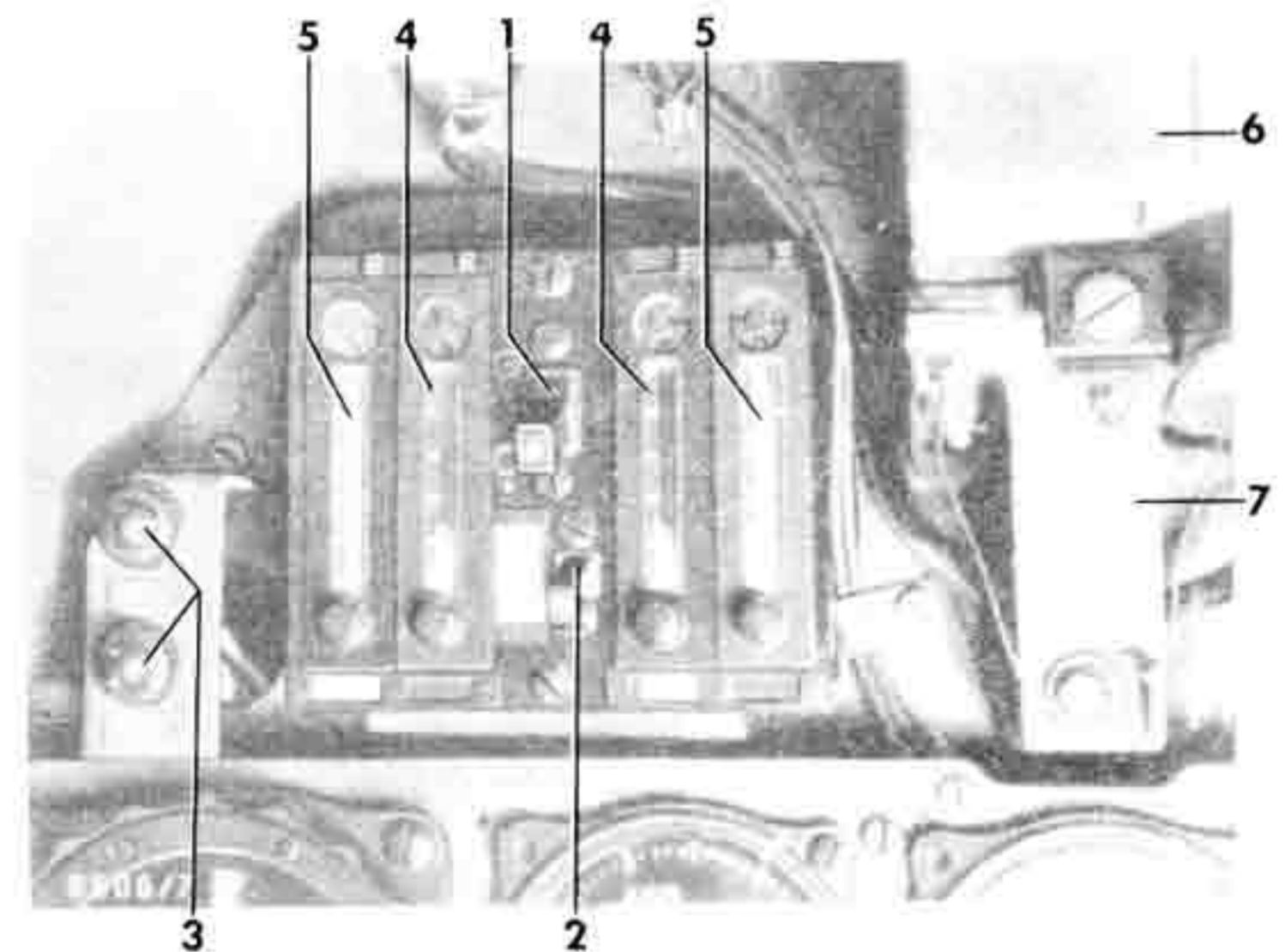

Fig. 17: Aircraft trestled and restrained, synchronized weapons calibration disk fitted



- 1 Safety switch I
- 2 Safety switch II
- 3 Breechblock control lights (MG 131s)  
(normally mounted horizontally)
- 4 Rounds counters - wing-root MG 151/20Es
- 5 Rounds counters - outboard MG 151/20Es
- 6 Revi 16B gunsight
- 7 Gunsight mounting unit

Fig. 18: SZKK-4

### Fuselage MG 131s



1 MG 131 link belt segment/cartridge casing discard chute  
2 MG 131 ammunition boxes

Fig. 19

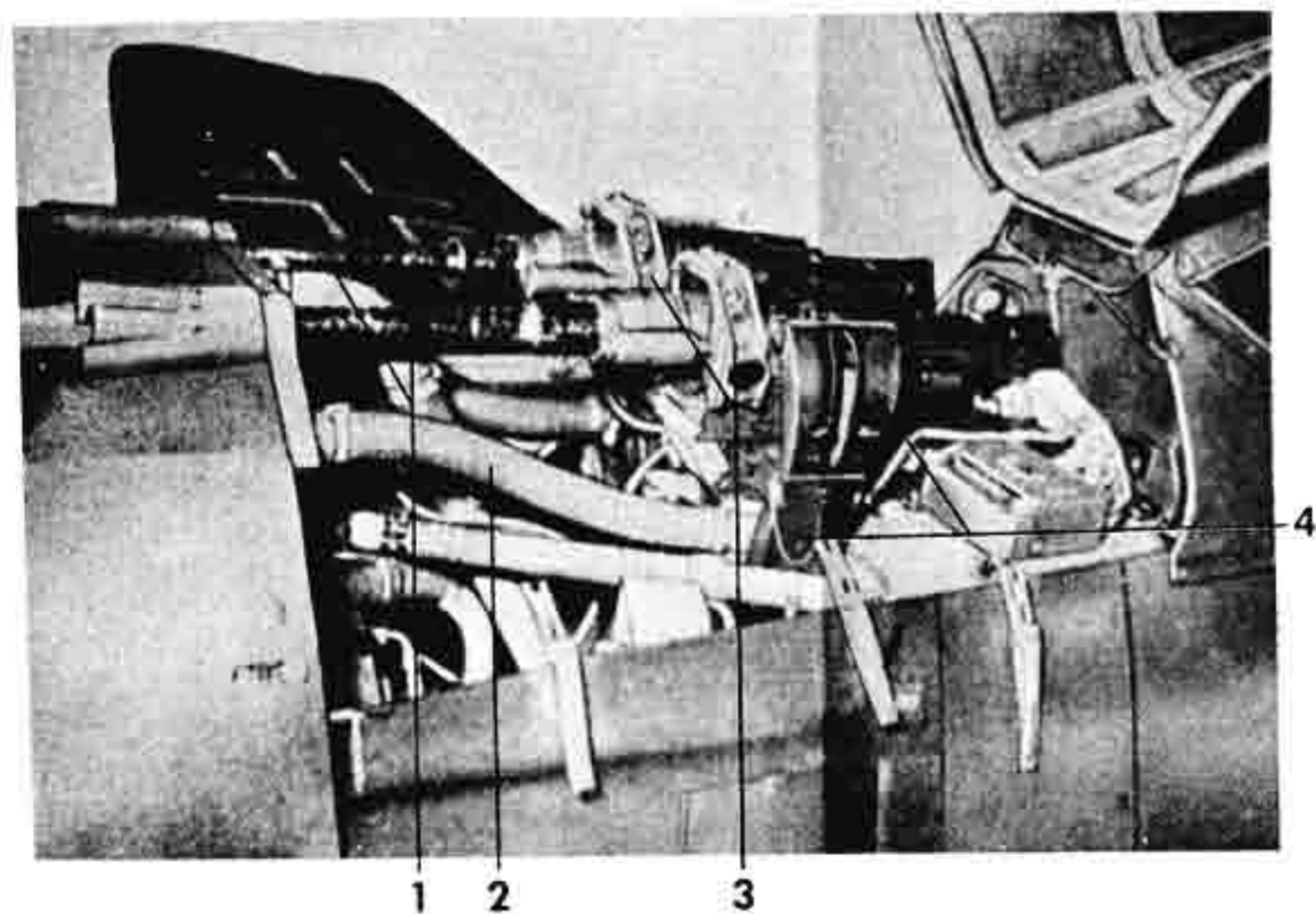

1 MG 131s  
2 Ammunition cooling pipe  
3 StL 131/5B weapon mounts  
4 Ammunition feed chutes

Fig. 20

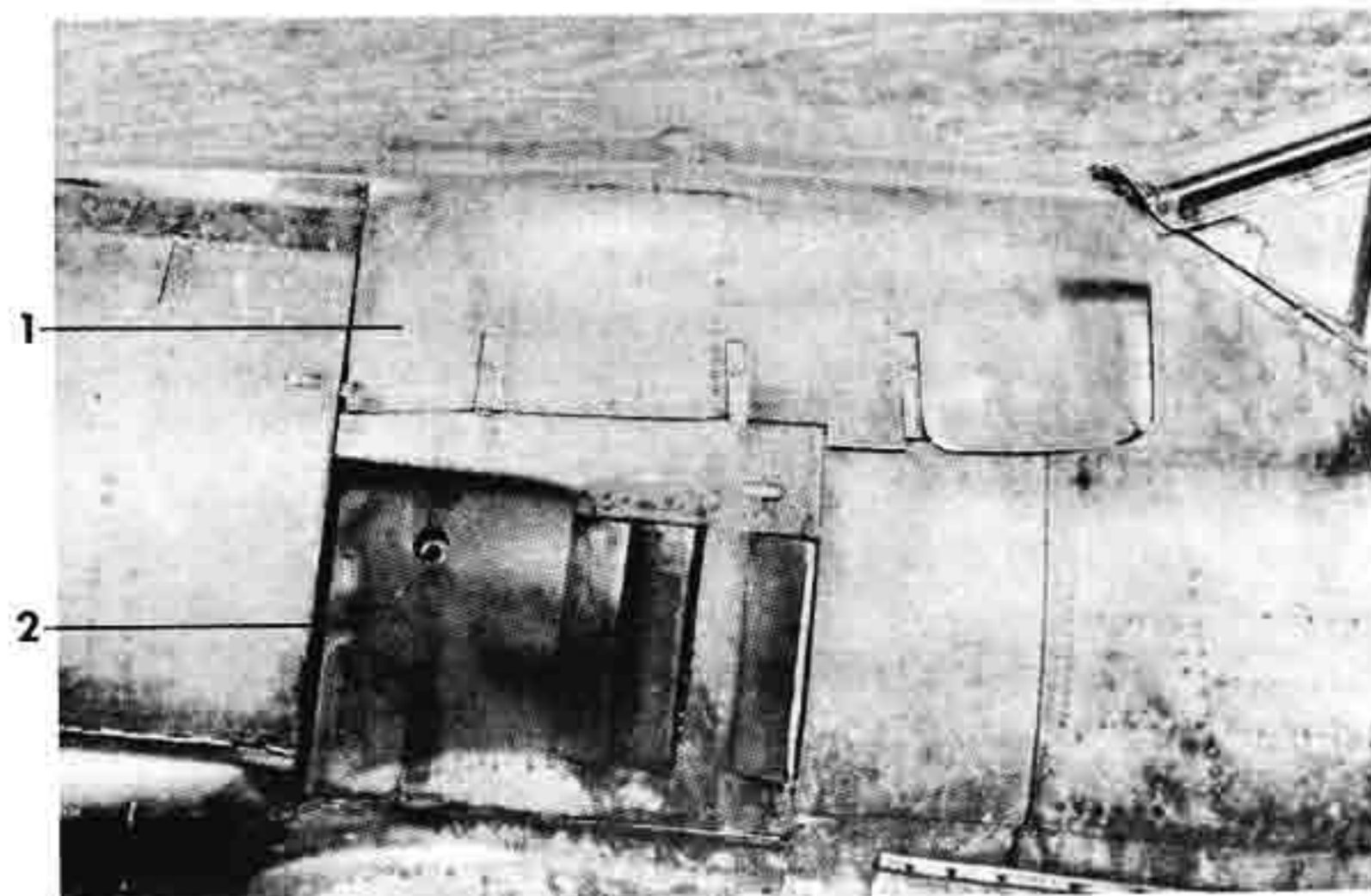

1 Fuselage armament panel  
2 Fuselage side panel

Fig. 21

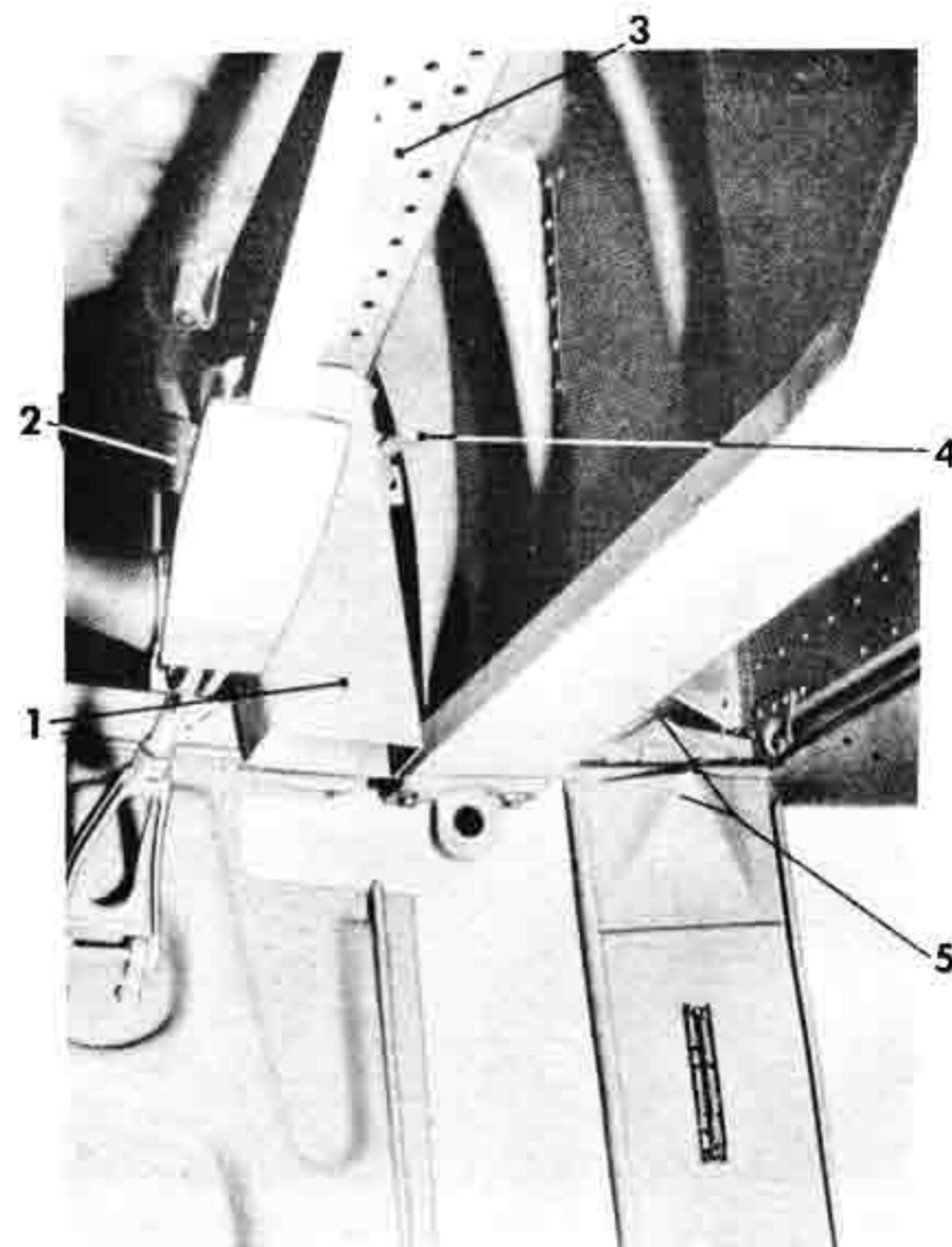

1 MG 131 link belt segment/cartridge casing discard chute  
2 Discard chute hinge  
3 MG 131 ammunition box  
4 Discard chute lock release lever  
5 MG 151/20 ammunition box lock

Fig. 22

Wing-root MG 151/20Es

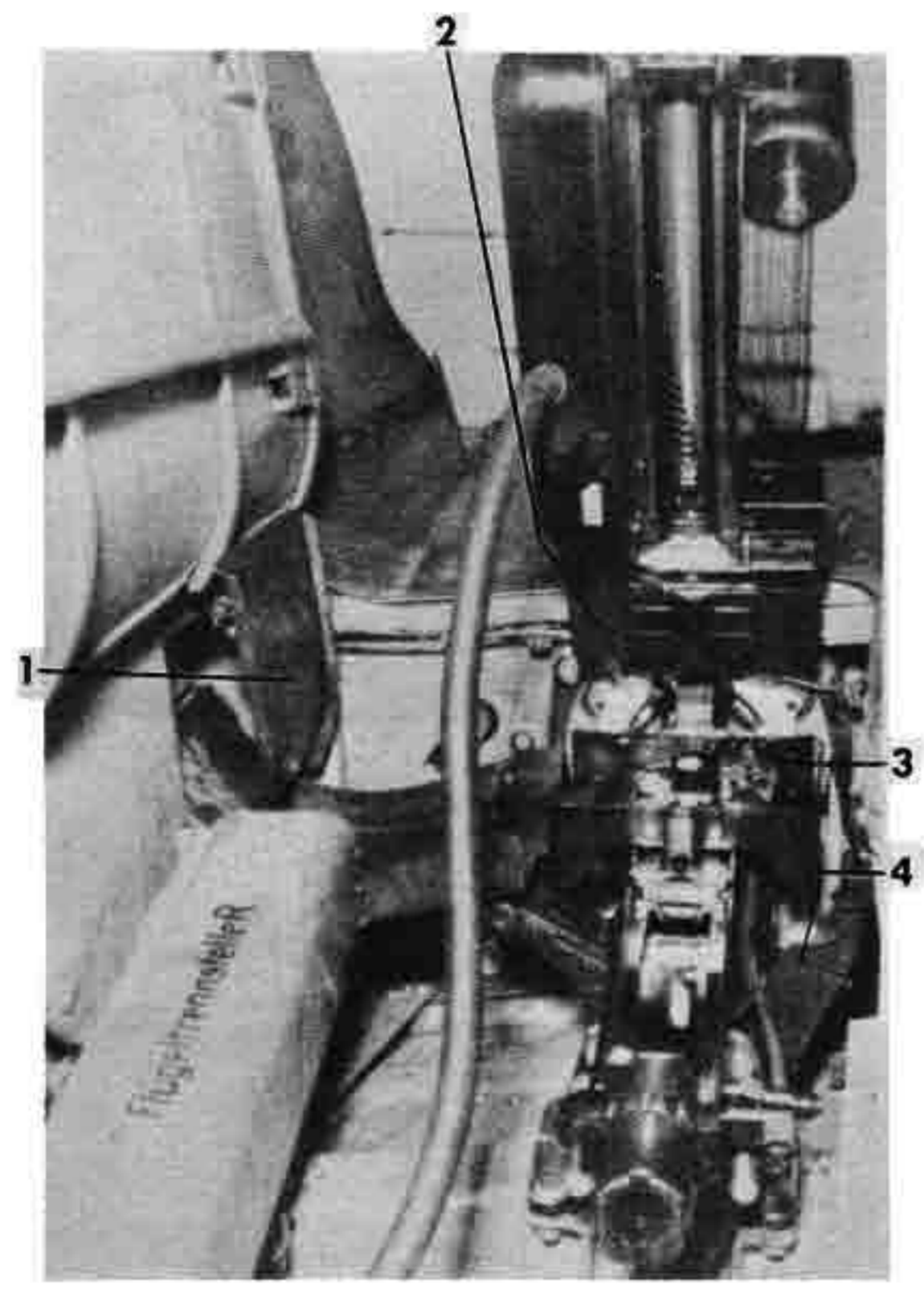

- 1 Ammunition feed chute (open)
- 2 MG 151/20E with breech open
- 3 Ammunition belt guide
- 4 Link belt discard chute

Fig. 23

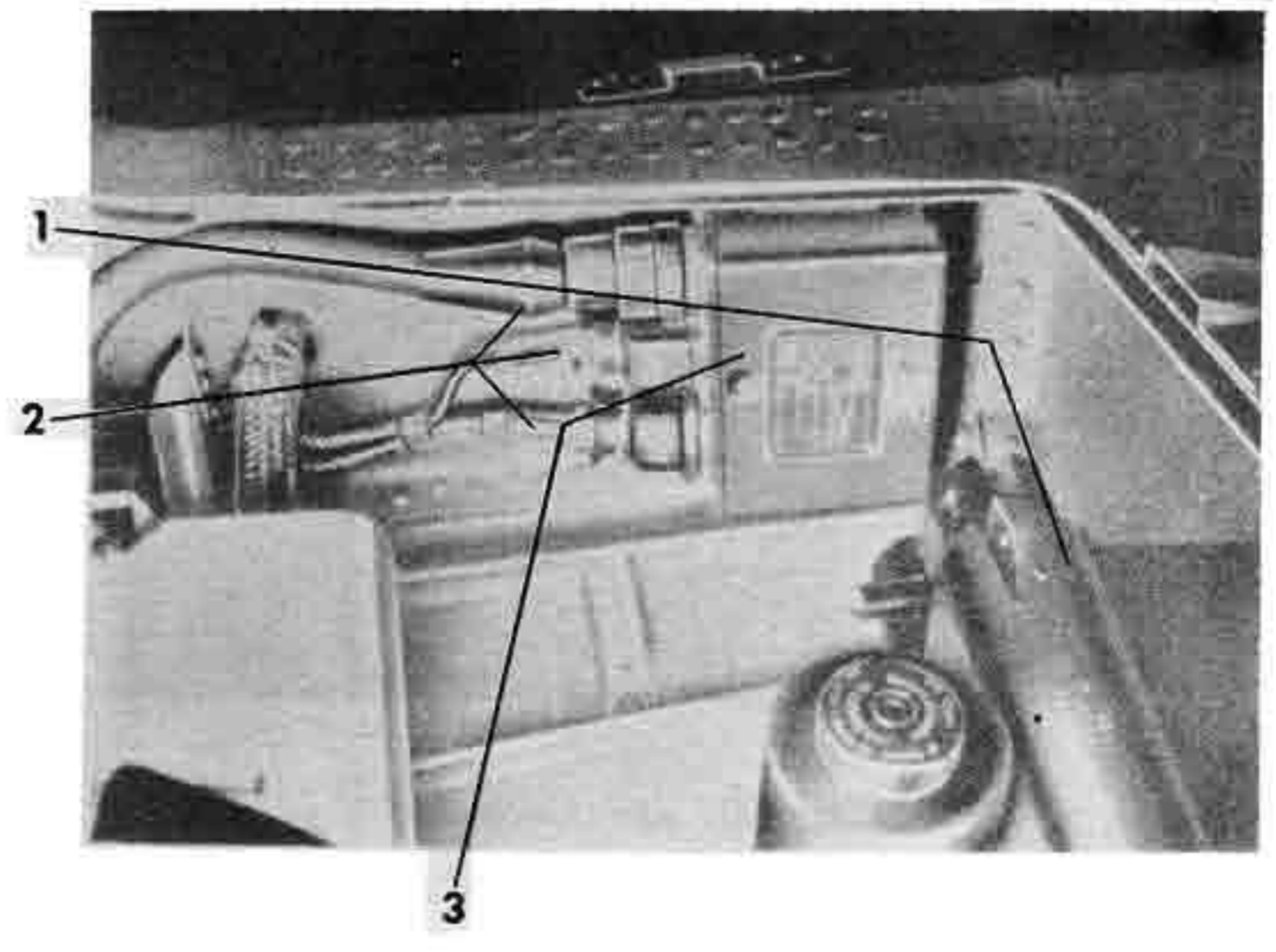

- 1 MG 151/20E
- 2 Weapon cocking and firing leads
- 3 EDSK-B1 gun cocking control box

Fig. 25

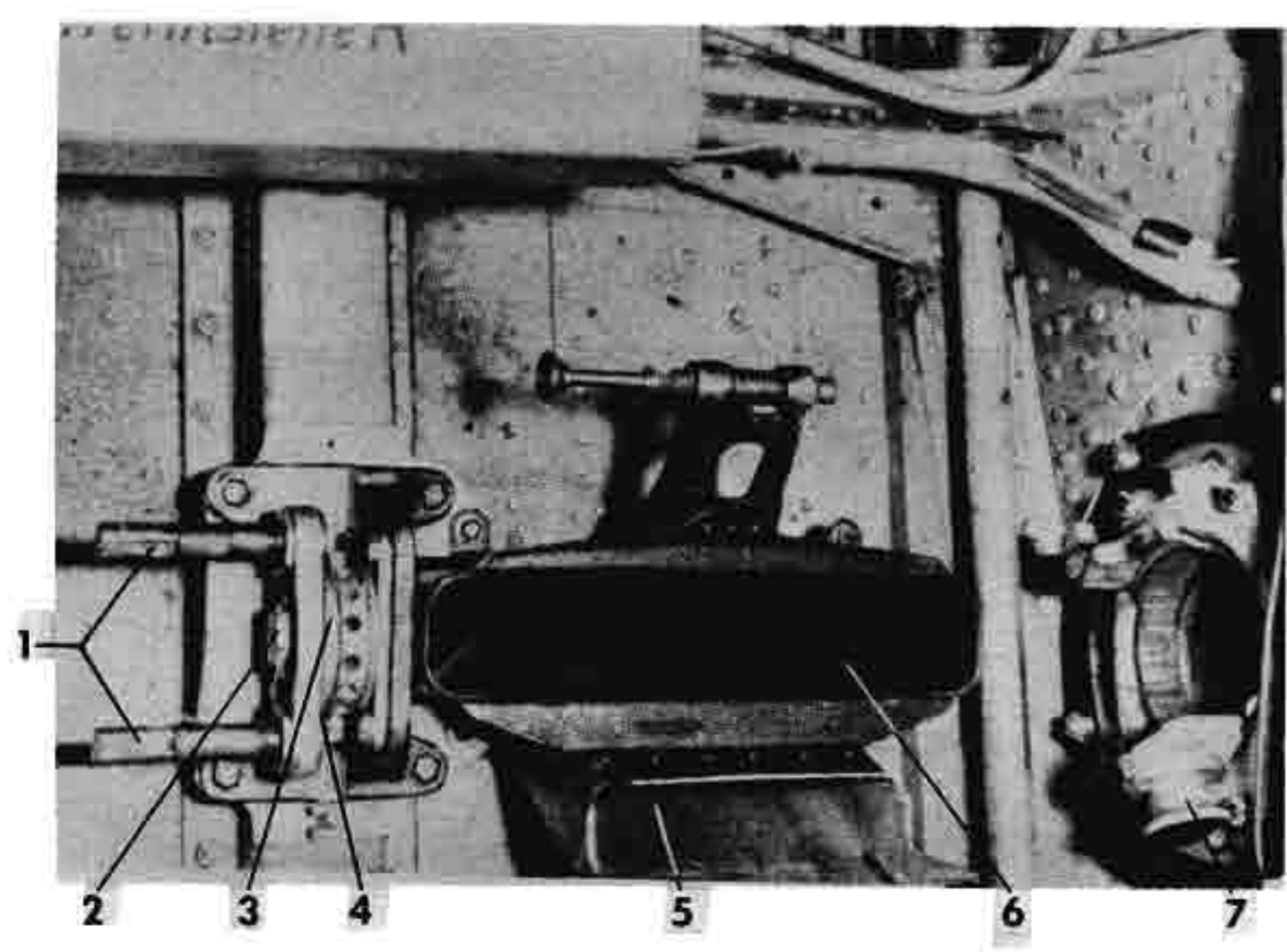

- 1 Rear mount
- 2 Safety screw
- 3 Weapon rotation disk
- 4 Horizontal adjustment screw
- 5 Link belt discard chute
- 6 Cartridge casing discard chute
- 7 Forward mount locking button

Fig. 24

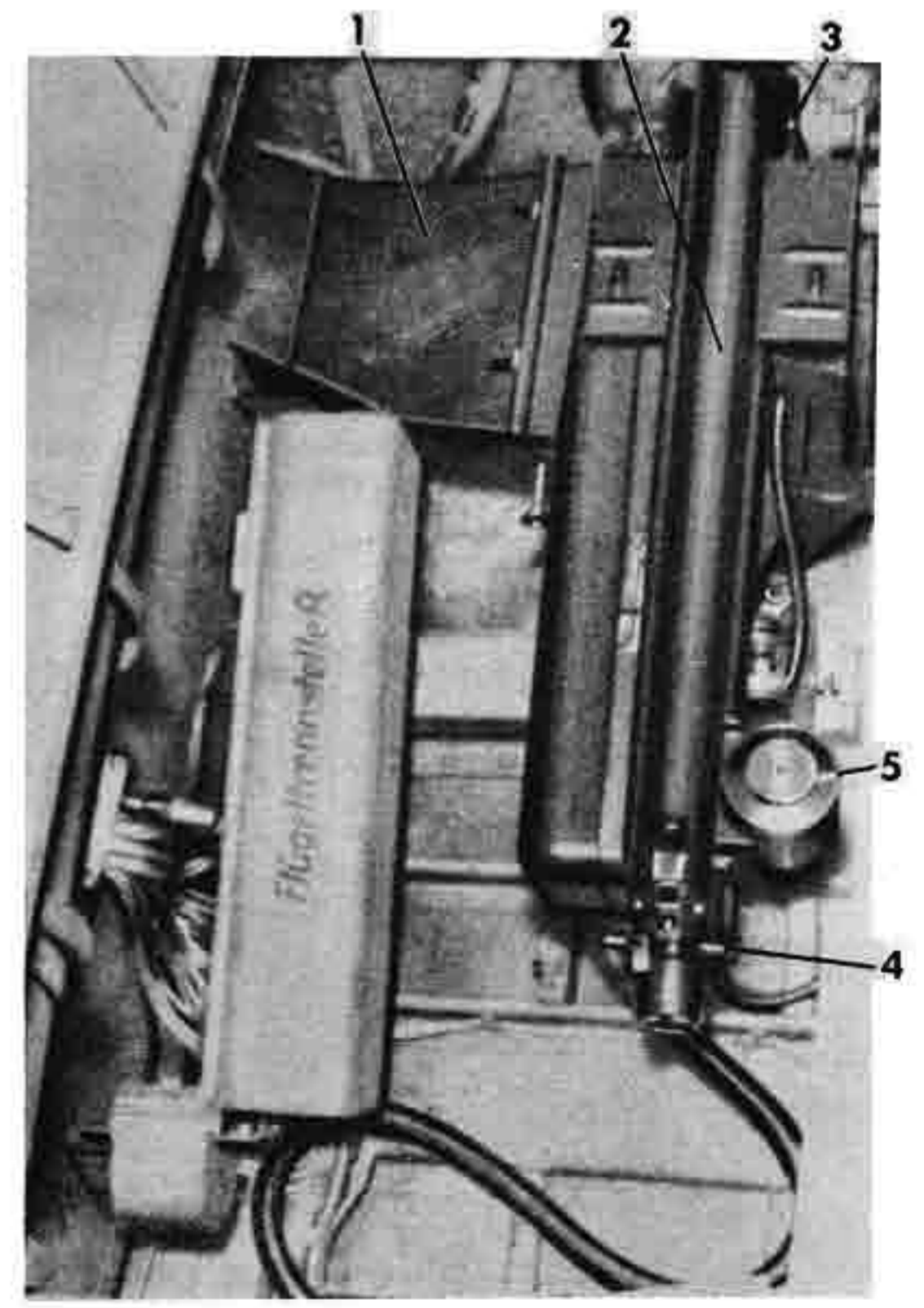

- 1 Ammunition feed chute
- 2 MG 151/20E
- 3 Forward mount locking button
- 4 Manual charging handle
- 5 EA firing unit

Fig. 26

### Outboard MG 151/20Es

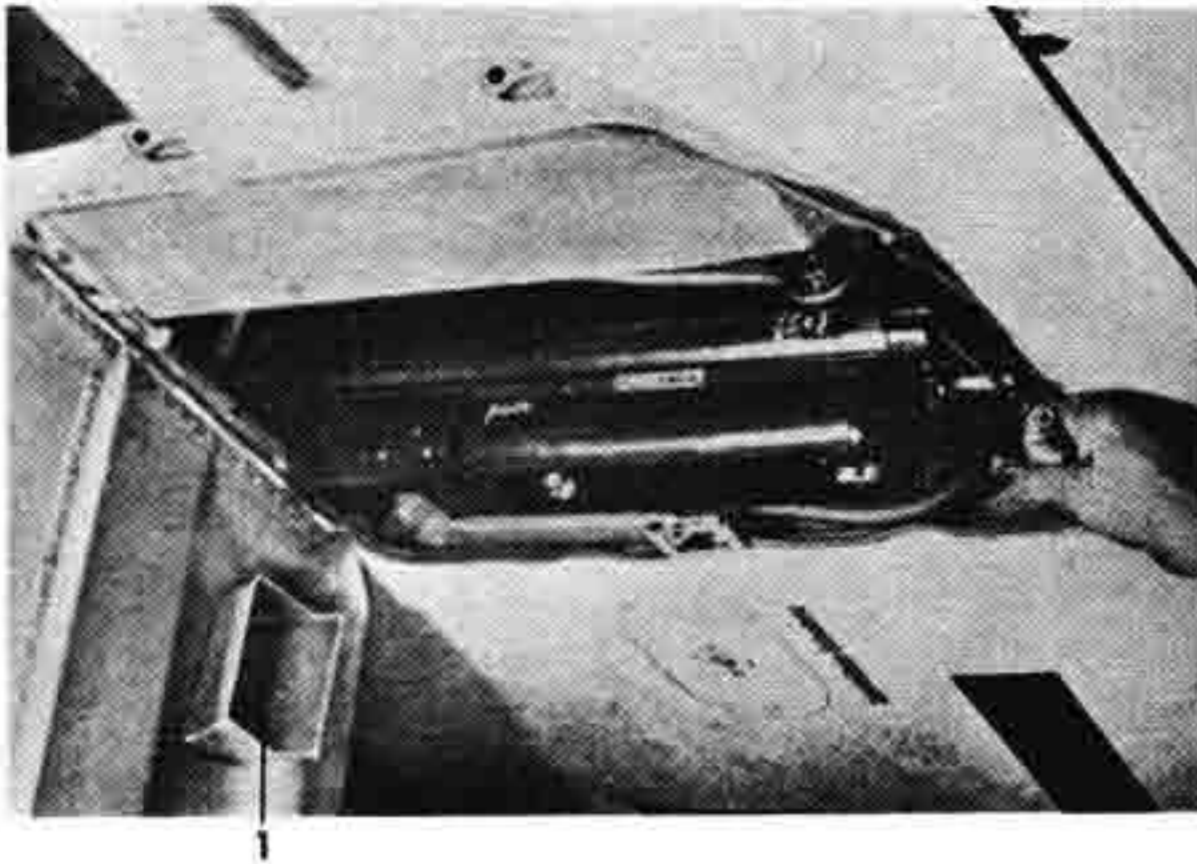

1 Link belt ejection chute  
 Fig. 27: Manual gun charging



Fig. 30: Installing the loaded ammunition box

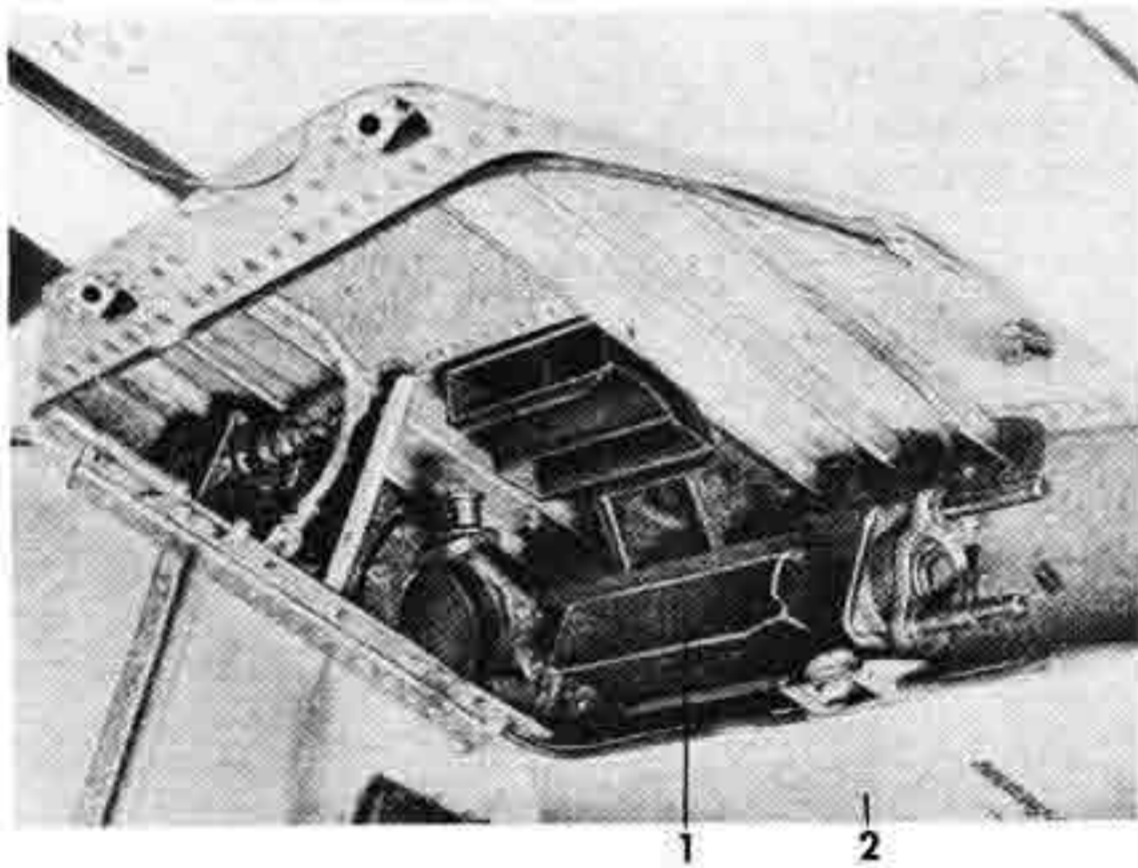

1 Cartridge casing ejection chute  
 2 Cartridge casing retrieval cover  
 Fig. 28

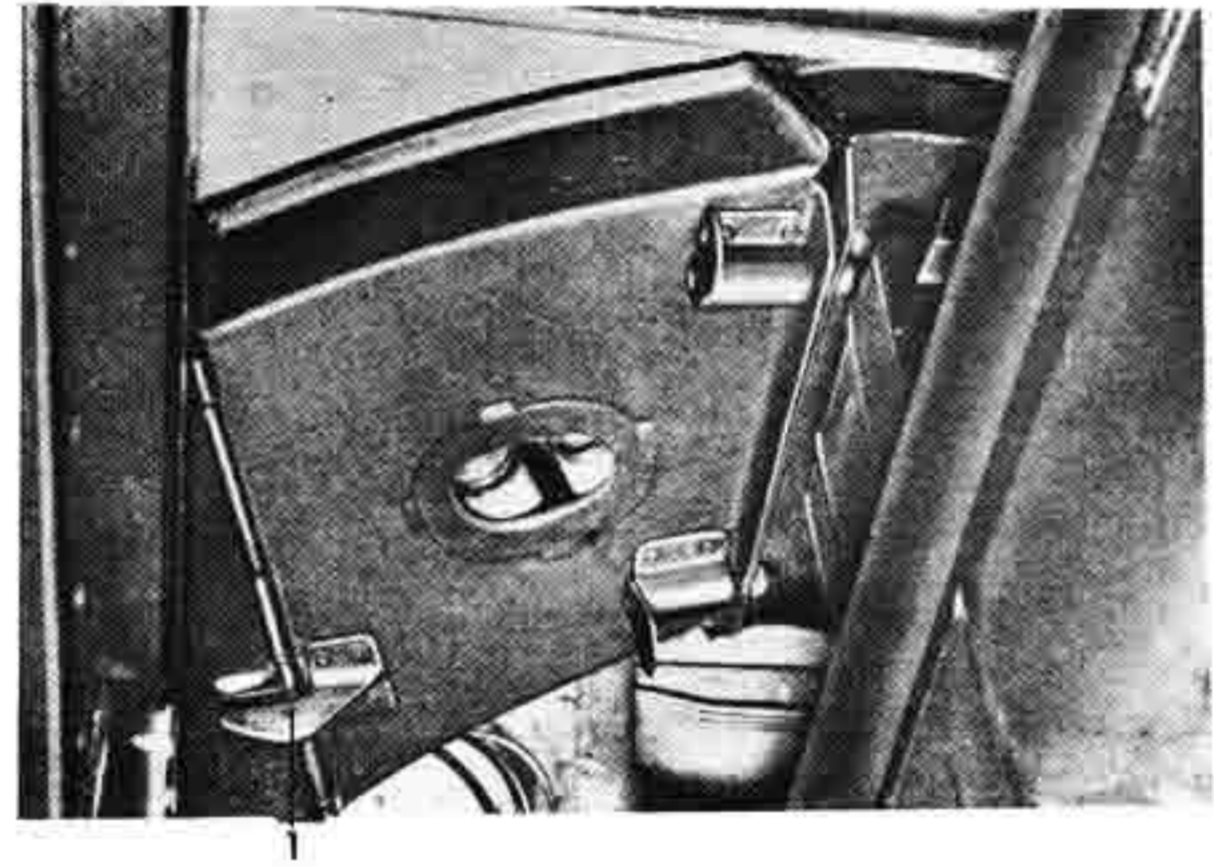

1 Ammunition belt catch  
 Fig. 31: Ammunition feed attached

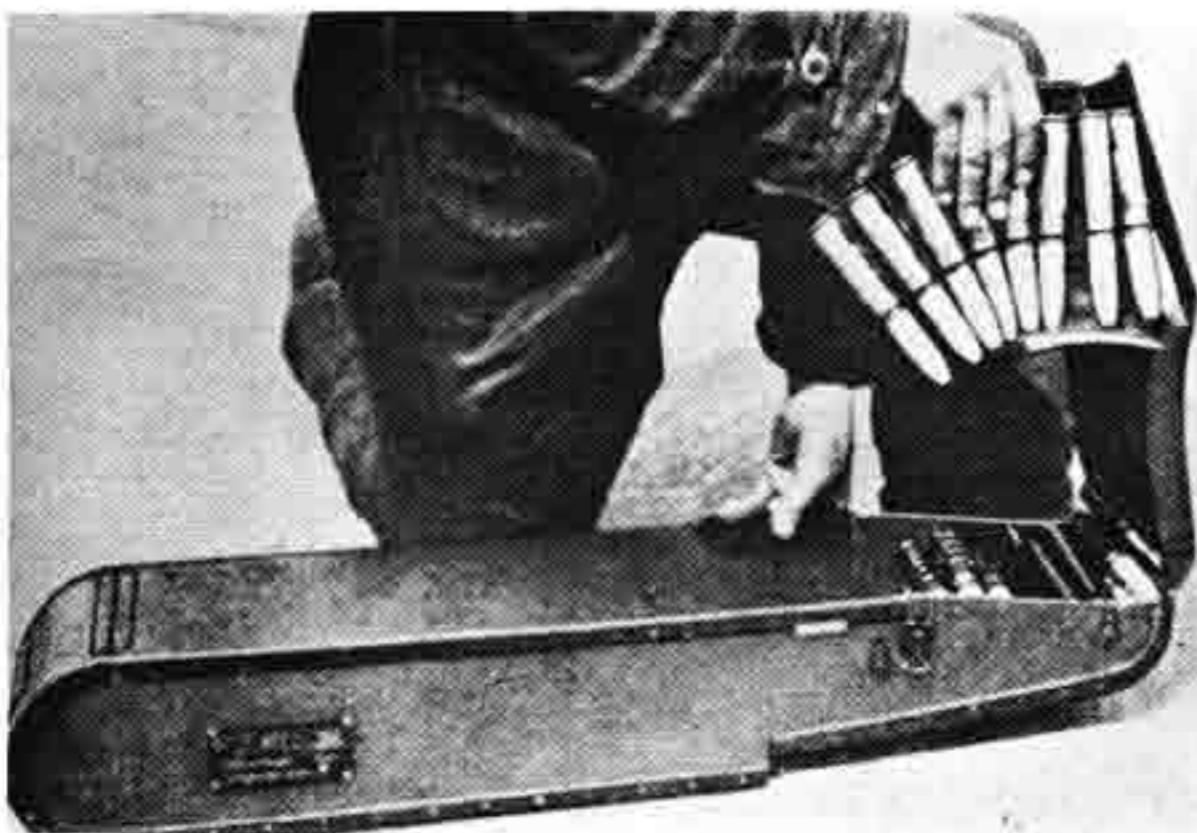
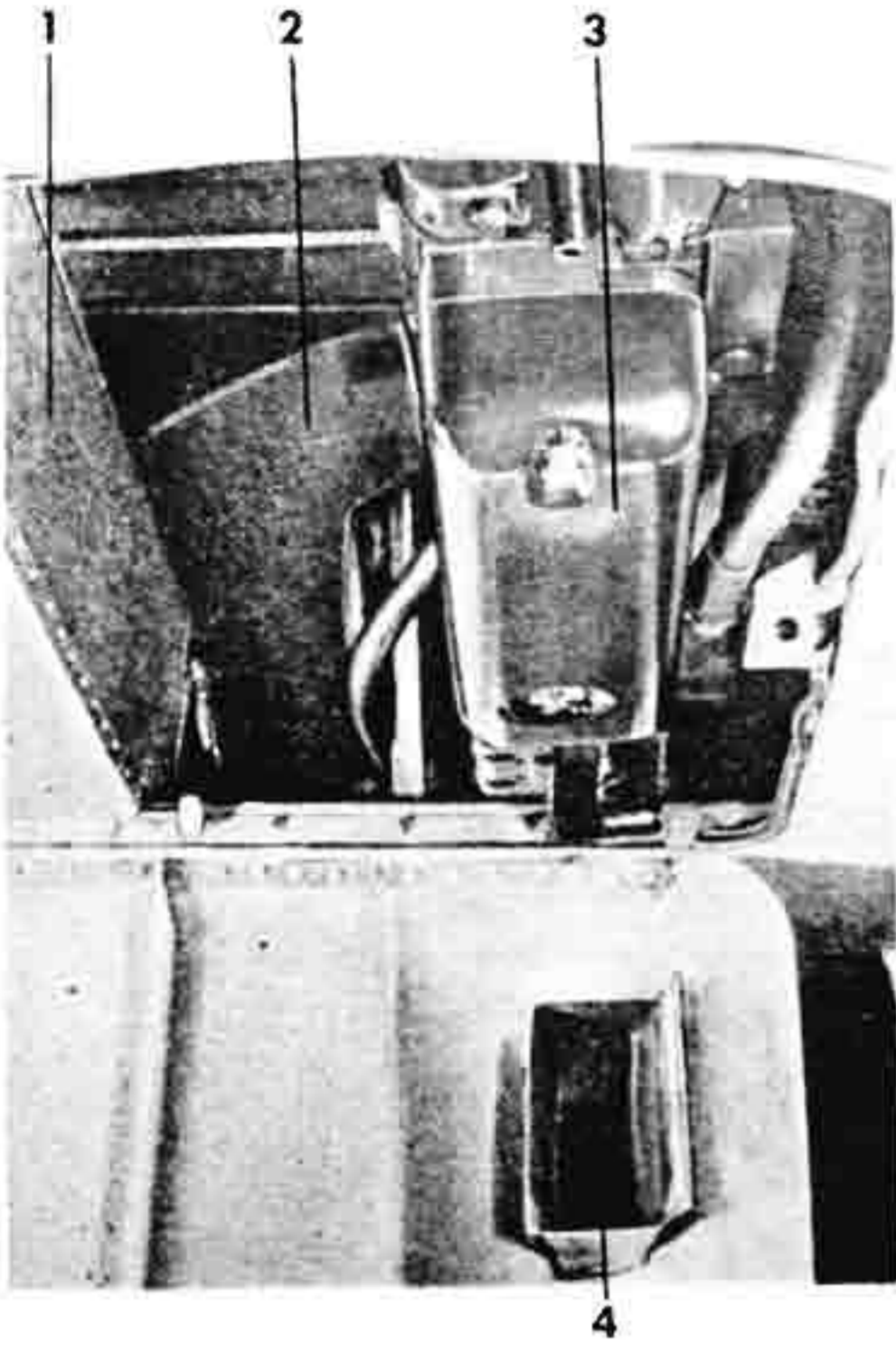

Fig. 29: Closing the loaded ammunition box



Fig. 32: Barrel removal (Method b)



- 1 Ammunition box
- 2 Ammunition feed chute
- 3 MG 151/20E
- 4 Link belt ejection chute

Fig. 33





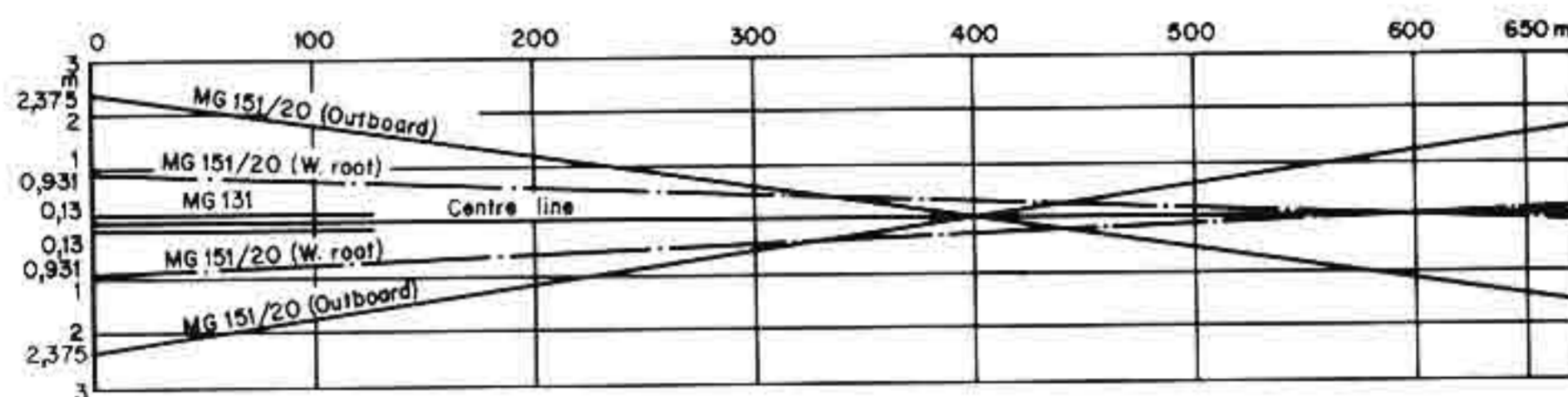
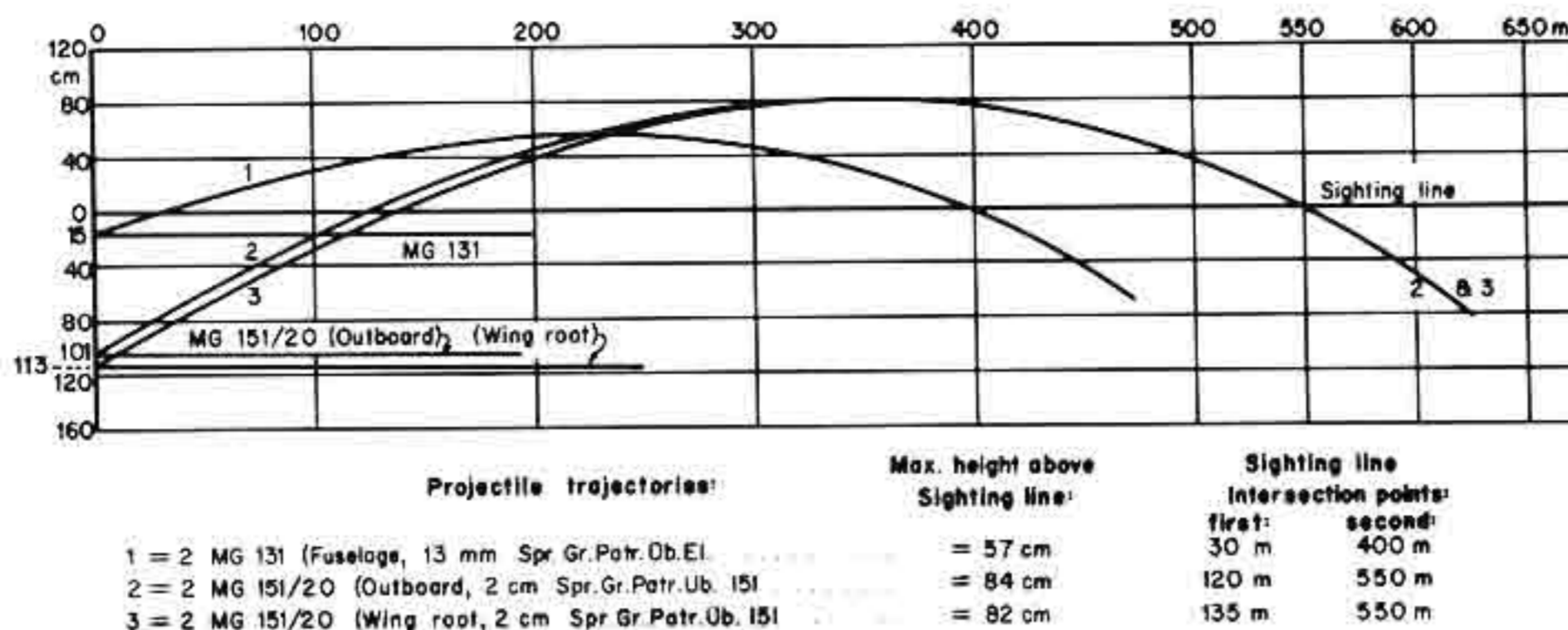

Annex A

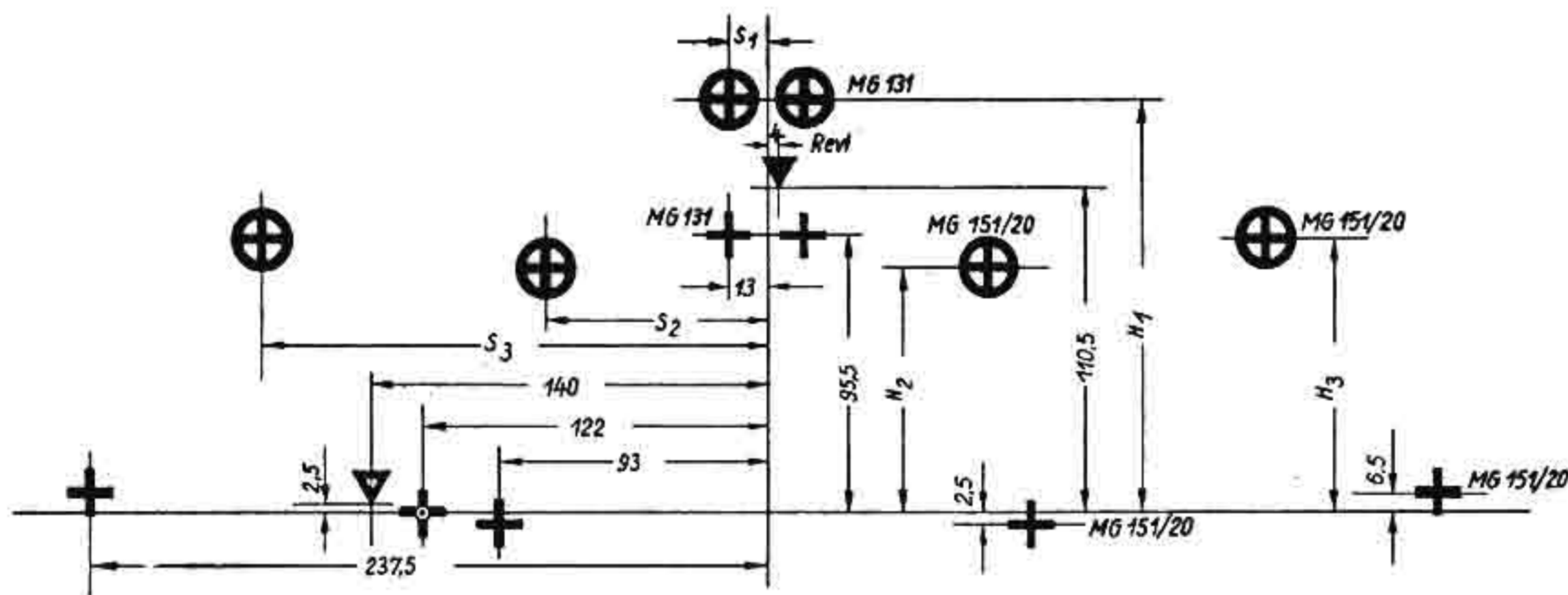

Weapons:

Fuselage: 2 MG 131  
 Wing-roots: 2 MG 151/20  
 Outboard: 2 MG 151/20

Alignment:

Harmonization 400m, Crossover: parallel  
 Harmonization 550m, Crossover: 600m  
 Harmonization 550m, Crossover: 400m

Ammunition:

13mm Spr.Gr.Patr.Ub.El.  
 2cm Spr.Gr.Patr.Ub.151/20  
 2cm Spr.Gr.Patr.Ub.151/20

Gunfire strike table at 50m and 100m, in cm

Range	Fuselage 2 MG 131		Wing-root 2 MG 151/20		Outboard 2 MG 151/20	
	H <sub>1</sub>	S <sub>1</sub>	H <sub>2</sub>	S <sub>2</sub>	H <sub>3</sub>	S <sub>3</sub>
0m	95,5	13	-2,5	93	6,5	237,5
50m	121	13	44	85	53	208
100m	142	13	85	78	94	178

Annex B

# Revi 16B

## A. General

### 1. General

The 'Revi 16B' is an optical gunsight designed for use with aircraft fixed weapons, both synchronized and unsynchronized.

The gunsight can be mounted in any position. It is fitted with a built-in dimmer rheostat, and is attached to the aircraft electrical system by spring-loaded contacts.

### 2. Technical data

Weight . . . . . approx. 0,8 kg (1.76 lb)

Size:

Height . . . . . approx. 126 mm (4.96 in)

Width . . . . . approx. 60 mm (2.36 in)

Length . . . . . approx. 130 mm (5.12 in)

Bulb specification . . . . . 21 watt, 24 volt

Tinted glass . . . . . 90% opacity

Night filter . . . . . Tone 71 (Dark green)

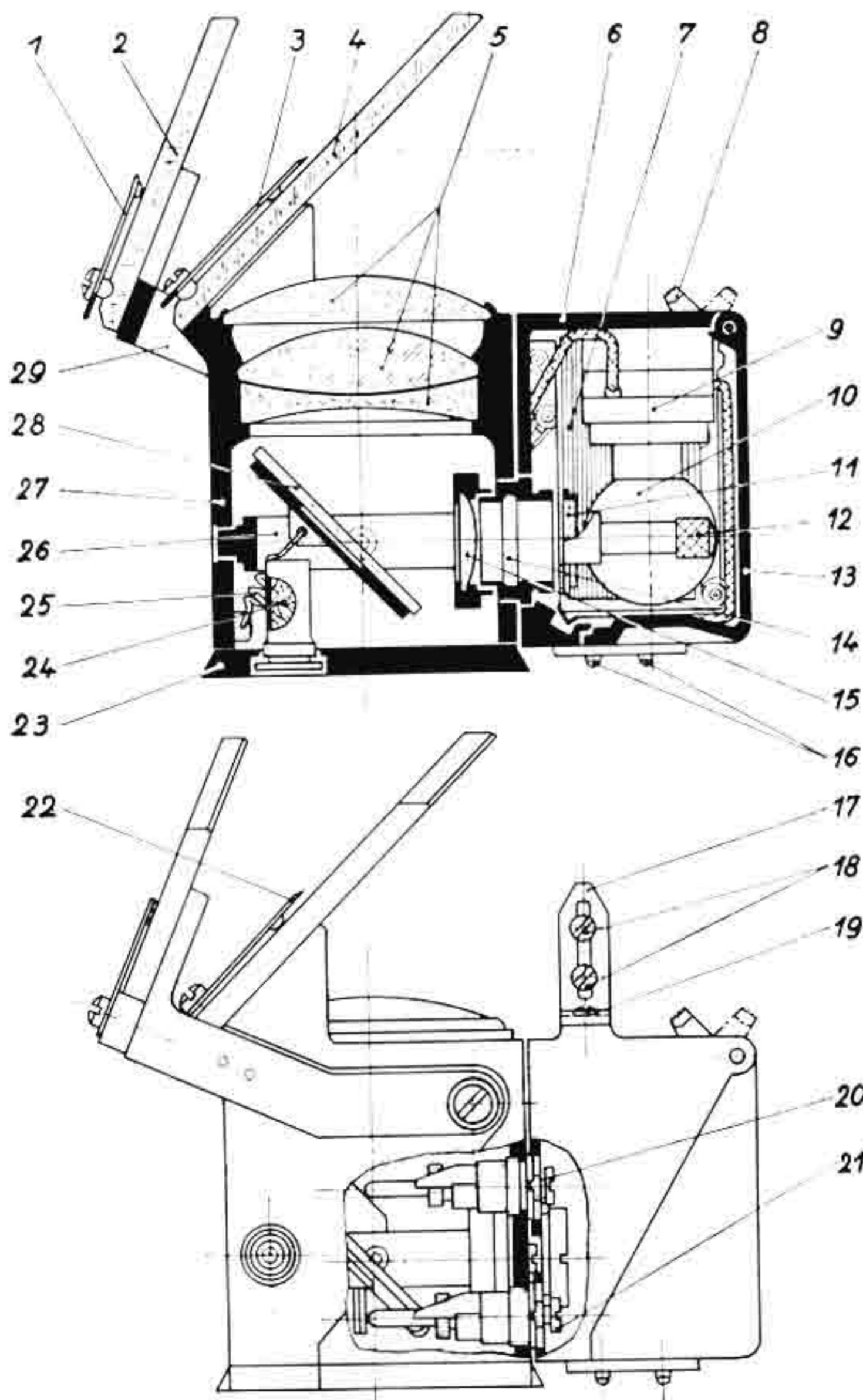

- 1 Tinted glass retaining spring
- 2 Tinted glass plate
- 3 Reflector plate retaining spring
- 4 Reflector plate
- 5 Objective lenses
- 6 Light bulb housing
- 7 Dimmer rheostat
- 8 Dimmer switch
- 9 Bulb holder
- 10 Light bulb
- 11 Night filter
- 12 Filter switch
- 13 Bulb housing cover
- 14 Non-reflective glass cover
- 15 Sighting image lens
- 16 Spring-loaded electrical contacts
- 17 Blade rear sight
- 18 Vertical adjustment screws
- 19 Horizontal adjustment screws
- 20 Horizontal adjustment screw
- 21 Vertical adjustment screw
- 22 Post-type front sight
- 23 Base plate
- 24 Silica crystal capsule
- 25 Adjustment spring
- 26 Cardan mount
- 27 Lens chamber
- 28 Mirror
- 29 Tinted glass swinging support arm

The vertically mounted engraved sighting image comprises an aiming cross with deflection graduation marks, and a range circle. The angular distance between graduations is  $1^\circ$ . The range circle diameter is equal to 10% of the range (i.e. it has a diameter of 10 yds at 100 yds range).

## B. Description

### 1. General

The Revi 16B consists basically of the lens chamber (27). To this is attached the reflector plate (4), the movable tinted glass plate (2), and the light bulb housing (6).

### 2. Optical sight

The optical sight includes the light bulb (10), the night filter (11), the non-reflective cover glass (14), the sighting image lens (15), the mirror (28), the focussing lenses (5), and the reflector plate (4). The reflector, and tinted glass, plates are lightly held in place by retaining springs (3) and (1). The tinted glass plate (2) is positioned by manually rotating its support arms (29). The line of sight can be adjusted  $\pm 2.5^\circ$  horizontally with adjustment screw (20), and  $\pm 3^\circ$  vertically with adjustment screw (21). These screws are reached by raising

the bulb housing cover (13). The mirror (28) is positioned in a Cardan mount (26); spring tension (25) ensures a positive response to any adjustments. The base (23) seals the bottom of the lens

The base plate (23) seals the bottom of the lens chamber (27), and also acts as the gunsight attachment point. In addition, it houses a Silica crystal capsule (24), which is used to absorb any moisture entering the chamber.

### 3. Mechanical sight

The mechanical sight consists of a blade rear sight (17) and a post-type front sight (22). The front sight comprises the upper portion of the reflector plate left retaining spring (3). The sight, after loosening screws (18) and (19), can be adjusted  $\pm 3^\circ$  vertically and/or horizontally.

### 4. Lighting system

The lighting system includes the dimmer rheostat (7), the bulb holder (9), and the light bulb (10). The bulb draws power from the aircraft electrical system (24 volt), via two spring-loaded contacts (16). Its brightness is controlled by a dimmer switch (8). To reduce sighting image glare during night operations, the night filter (11) can be rotated in front of the light bulb (10) by the filter switch (12); this switch is reached by raising the bulb housing cover (13).

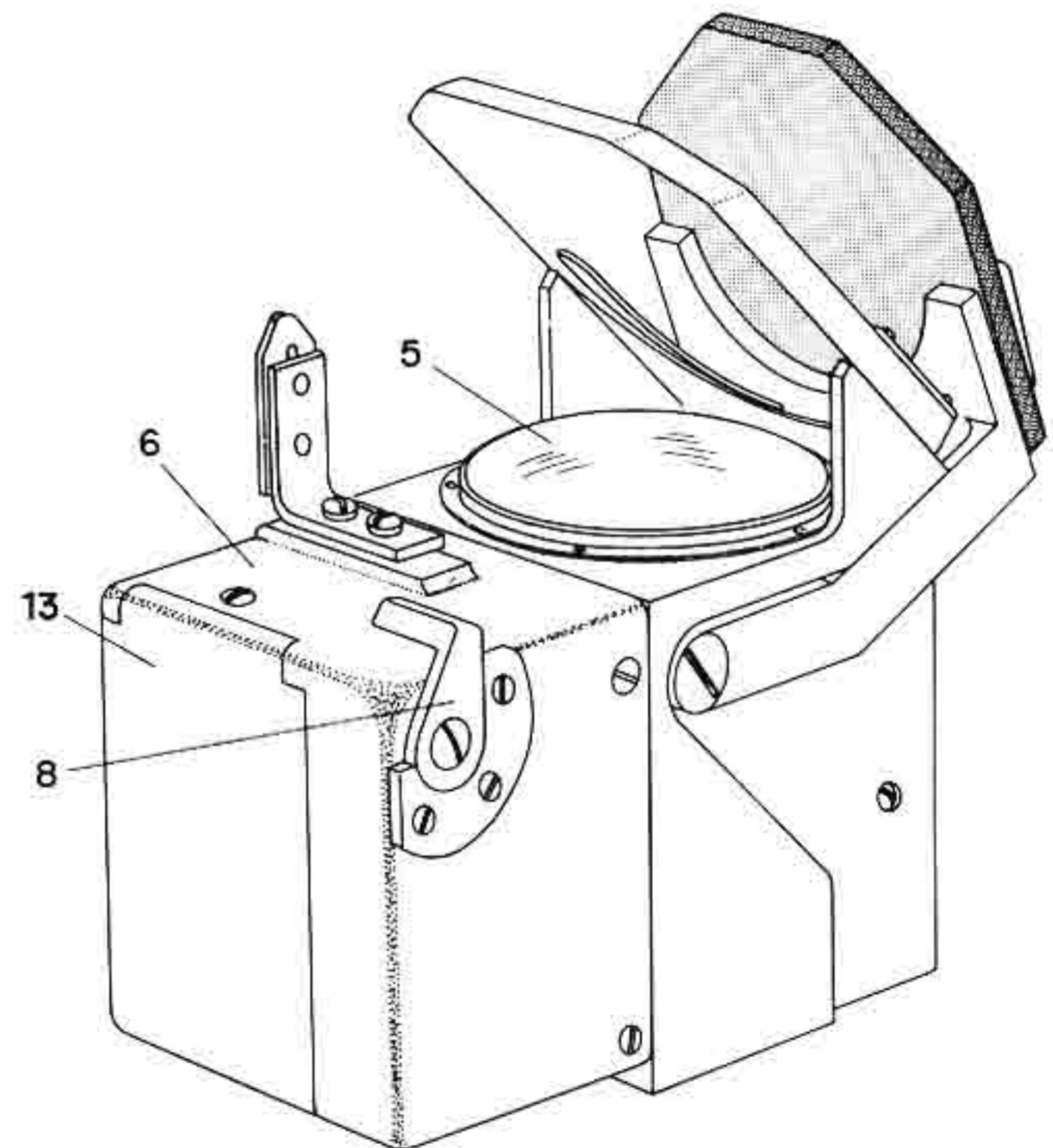
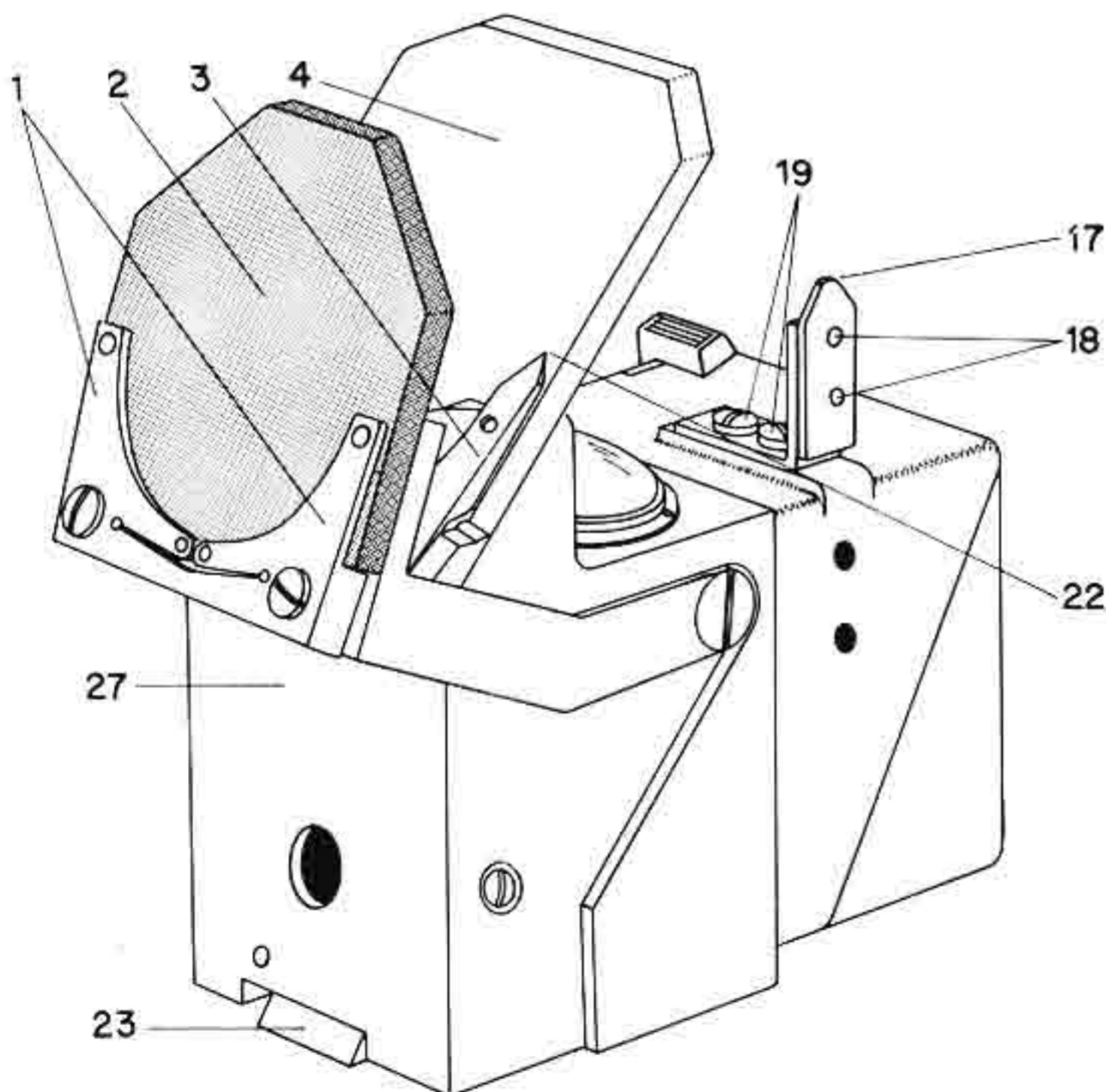

## C. Operation

When the light bulb is switched on, it illuminates the sighting image. This image is then reflected off the mirror, and is so adjusted by its passage through the objective lenses that when it is projected rearwards from the reflector plate, it appears, to the sighting eye, to originate at infinity, and, therefore, to superimpose itself upon the target along the line of sight.

The optical sight permits the sighting eye:

1. To shift a distance of up to approximately 50 mm (1.97 in) without altering the line of sight; and,
2. To vary its distance from the reflector plate from about 200 mm (7.87 in) to about 450 mm (17.72 in) without affecting the size of the target.

Using the mechanical sight, on the other hand, the eye must be accurately lined up with the front sight—rear sight axis.

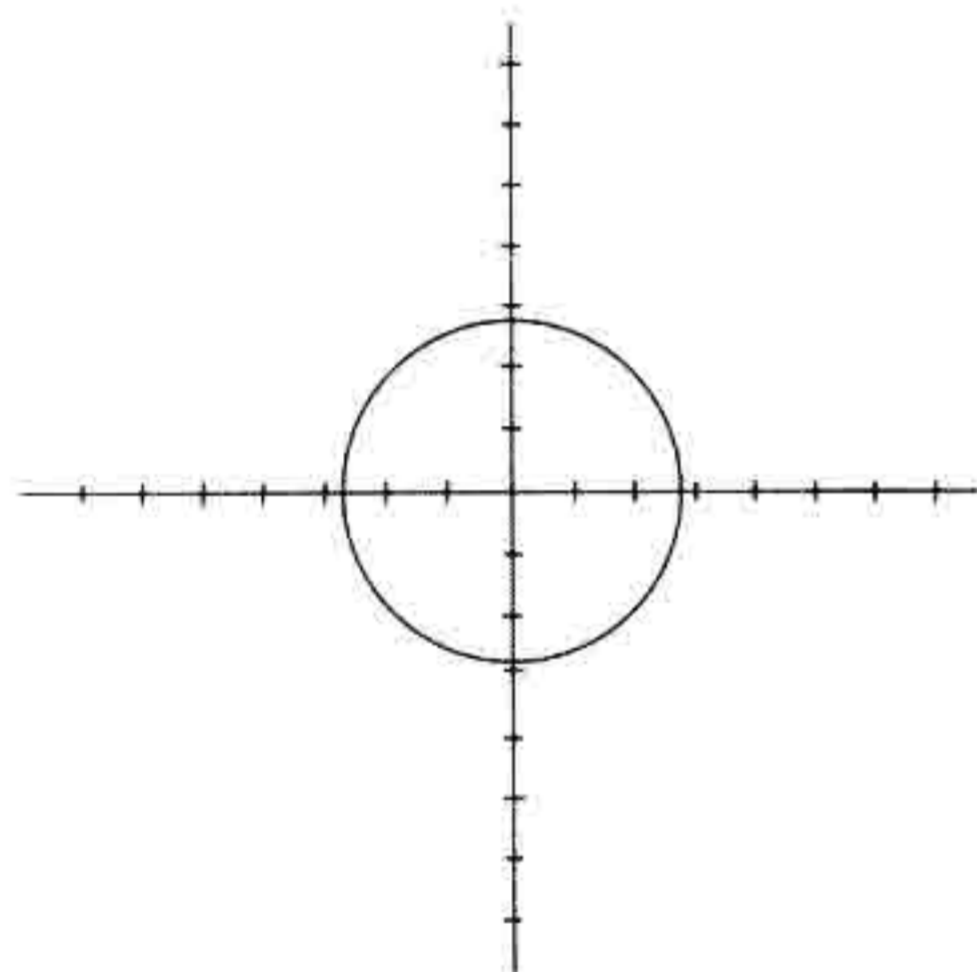

Revolver 16B sighting image



D. (Luft) T. 2190 A-8

For Official Use Only!

# **Fw 190 A-8**

Aircraft Handbook

**Part 8A**

**Armament installation**

**Supplement 1: A-8/R1**

**(Effective July 1944)**

**Issued September 1944**

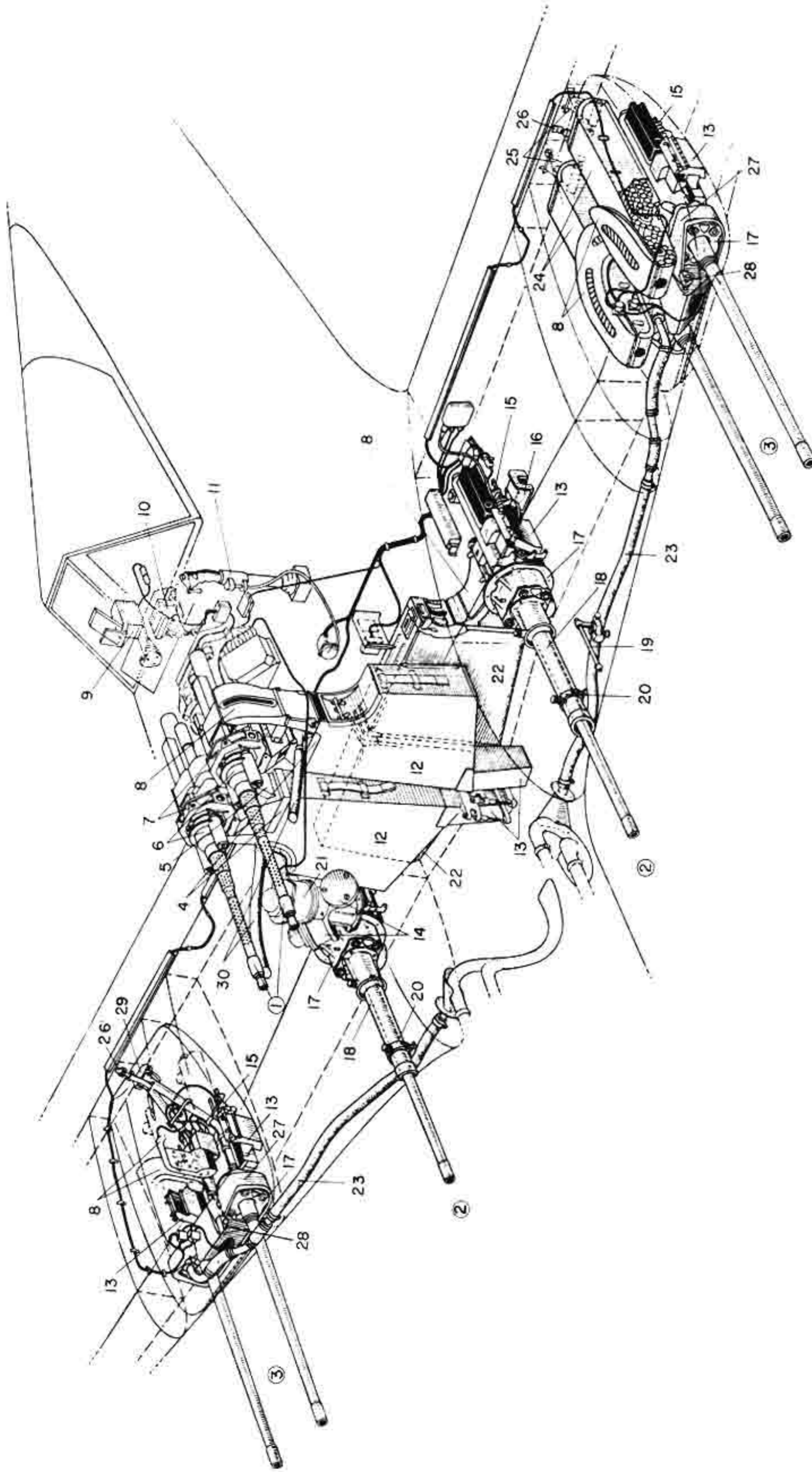

- 1 Fuselage MG 131 13mm machine guns
- 2 Wing-root MG 151/20E 20mm cannons
- 3 Outboard MG 151/20E 20mm cannons
- 4 Ammunition box attachment brackets
- 5 Link belt segment discard chute
- 6 MG 131 forward mount
- 7 STL 131/5B weapon mount
- 8 Ammunition feed chute
- 9 Revl 16B reflector gunsight
- 10 SZKK 4 armament switch counter, and control unit
- 11 KG 13B control stick
- 12 Fuselage weapons ammunition boxes (400 rounds each)
- 13 Link belt segment/cartridge casing discard chute
- 14 Fuselage weapons synchronizing gear
- 15 Adjustable rear mount
- 16 Rear mount support bracket
- 17 Non-adjustable forward mount
- 18 Cannon blast tube
- 19 Armament collimation tube
- 20 Barrel support clamp
- 21 Wing-root weapons synchronizing gear
- 22 Wing-root weapons ammunition boxes (250 rounds each)
- 23 Hot air pipe for ammunition warming
- 24 Outboard weapons ammunition boxes (125 rounds each)
- 25 Ammunition box rear suspension arms
- 26 Restraining cord for weapons carrier frame
- 27 Outboard weapons carrier frame
- 28 Carrier frame forward mounting point
- 29 Carrier frame rear mounting point
- 30 Cold air pipes for ammunition cooling

Fig 1: System skematic

## I. Description

The weapons system of the Fw 190A-8/R1 consists of:

- A. 2 synchronized MG 131s in the fuselage, with 400 rounds per gun.
- B. 2 synchronized MG 151/20Es in the wing-roots, with 250 rounds per gun.

- C. 4 unsynchronized MG 151/20Es, two beneath each outer wing panel, with 125 rounds per gun.

Use E-type ammunition for all MG 151/20Es.

## II. Gun mounts

### A. Fuselage MG 131s

The MG 131s are positioned within St.L 131/5B mounts which are fixed to a light metal carrier unit. These are, in turn, attached to Bulkhead 1 and to the Windscreen mounting frame.

### B. Wing-root MG 151/20Es

Each weapon is positioned in an St.L 151/2 mounting unit. The forward mount is attached to the main spar; and the rear mount, to a carrier unit between

Centre ribs 1 and 3.

### C. Gondola MG 151/20Es

(Equipment package R1 includes the two gondolas)

Each MG 151/20E is positioned in an ST.L 151/7 gun mount; two fixed to each weapons carrier frame. This carrier frame can be swung down for weapons loading and servicing. It is covered by a streamlined fairing (gondola).

## III. Ammunition placement and loading

### A. Fuselage MG 131s

The ammunition is positioned within the fuselage forward of Bulkhead 1. The 400 round boxes are removed from the aircraft for loading; then are slid up into the fuselage through the wheel cavities, and are held there by the hinged belt segment and cartridge casing chutes.

### B. Wing-root MG 151/20Es

The ammunition is positioned within the fuselage behind the main spar. The 250 round boxes are loaded outside the aircraft and slid up into the fuselage.

Hinged doors secure the boxes against sideward movement, and against falling out.

### C. Gondola MG 151/20Es

The ammunition is carried in 125 round boxes that lie within the wings, parallel to, and above, the weapons.

The boxes are loaded outside the aircraft and then, after swinging down the carrier frame, positioned within the wing. The boxes are secured at their forward and rear ends by spring-loaded bolts (See Fig. D).

## IV. Ammunition warming

### A. Fuselage MG 131s

The ammunition, positioned forward of Bulkhead 1 and directly behind the engine, is cooled by dynamic air drawn from behind the cooling fan.

### C. Gondola MG 151/20Es

Warm air, drawn from the engine exhausts, is led, via pipes in the wing leading edge, to the front of the weapons bay.

### B. Wing-root MG 151/20Es

Warm air radiated from the engine prevents the ammunition temperature from falling below  $-35^{\circ}\text{C}$ .

## V. Weapons sighting and alignment

(See Annexes A and B)

### A. Sighting

The Revi 16B gunsight is positioned behind an armoured windscreen, 50 mm thick and set at an angle of  $25^{\circ}$ . The shallow slope of the windscreen ensures that the reflection of the sighting image on the windscreen surface is not visible to the pilot. The field of view downwards is  $3^{\circ}$ .

### C. Adjustment

For weapons adjustment, a tube is provided in the left wing-root for positioning of a 7,9 mm collimator. Various bench marks are provided on the aircraft to ensure accurate levelling.

### B. Alignment

The weapons are to be adjusted to the alignment specified in Annex B.

## VI. Weapons electrical system

The electrical circuitry for each weapon is routed through the SZKK-4 switch, round counter, and control unit.

The fuselage and wing-root weapons are switched on by Safety Switch I; the outboard weapons, by Safety Switch II (Switch I must already be 'On'). The outboard weapons must be turned on no less than 3 seconds after the other weapons. This interval will ensure that the cocking of the inboard weapons has

been completed. As the aircraft can support the simultaneous charging of a maximum of only 4 guns, this action avoids the current overload that would otherwise result. A special instruction plate is fitted.

Two firing buttons, A and B1, are fitted on the KG 13B control column grip. The A-button fires the inboard weapons; the B1-button, the outboard weapons.



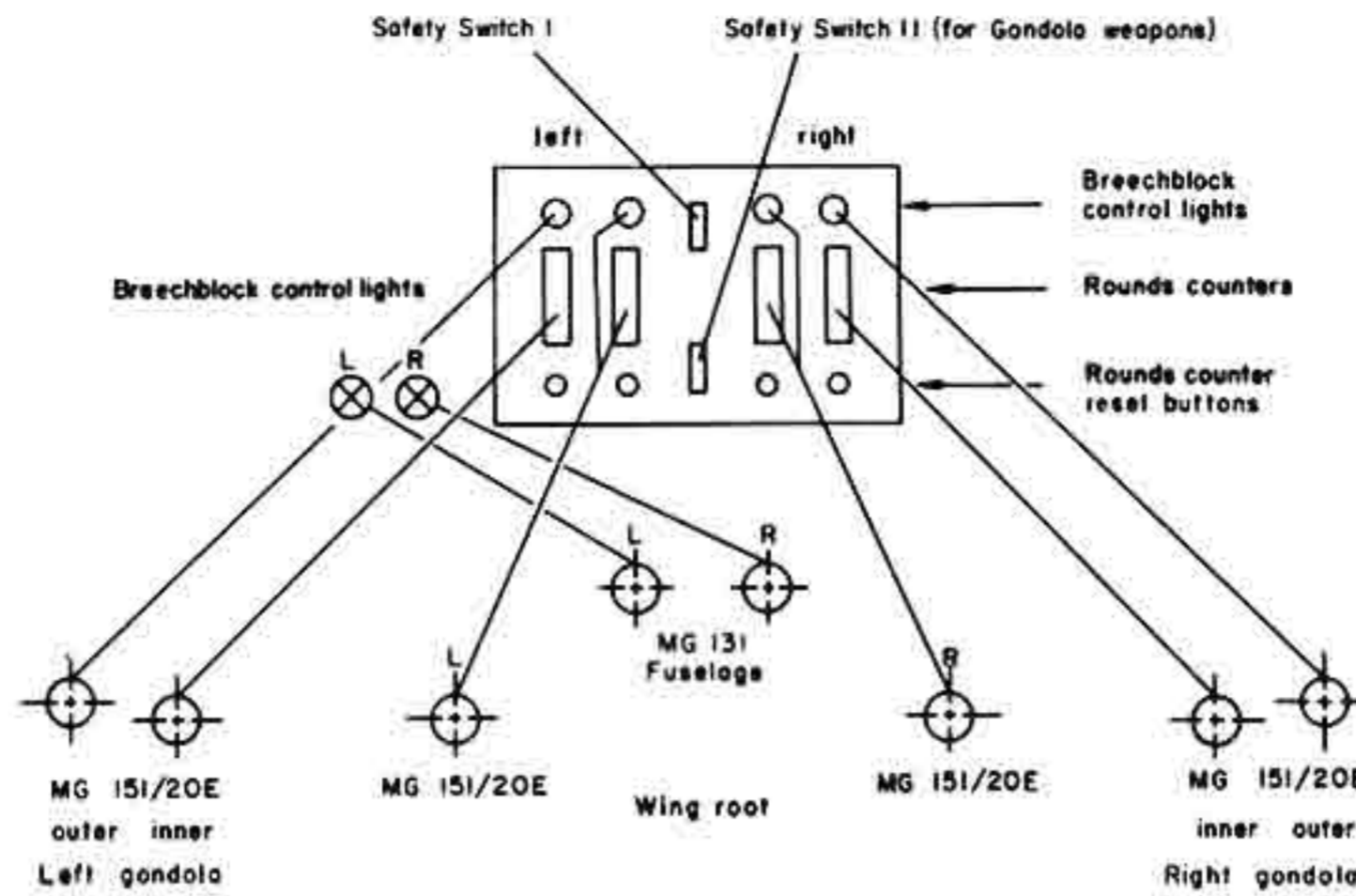
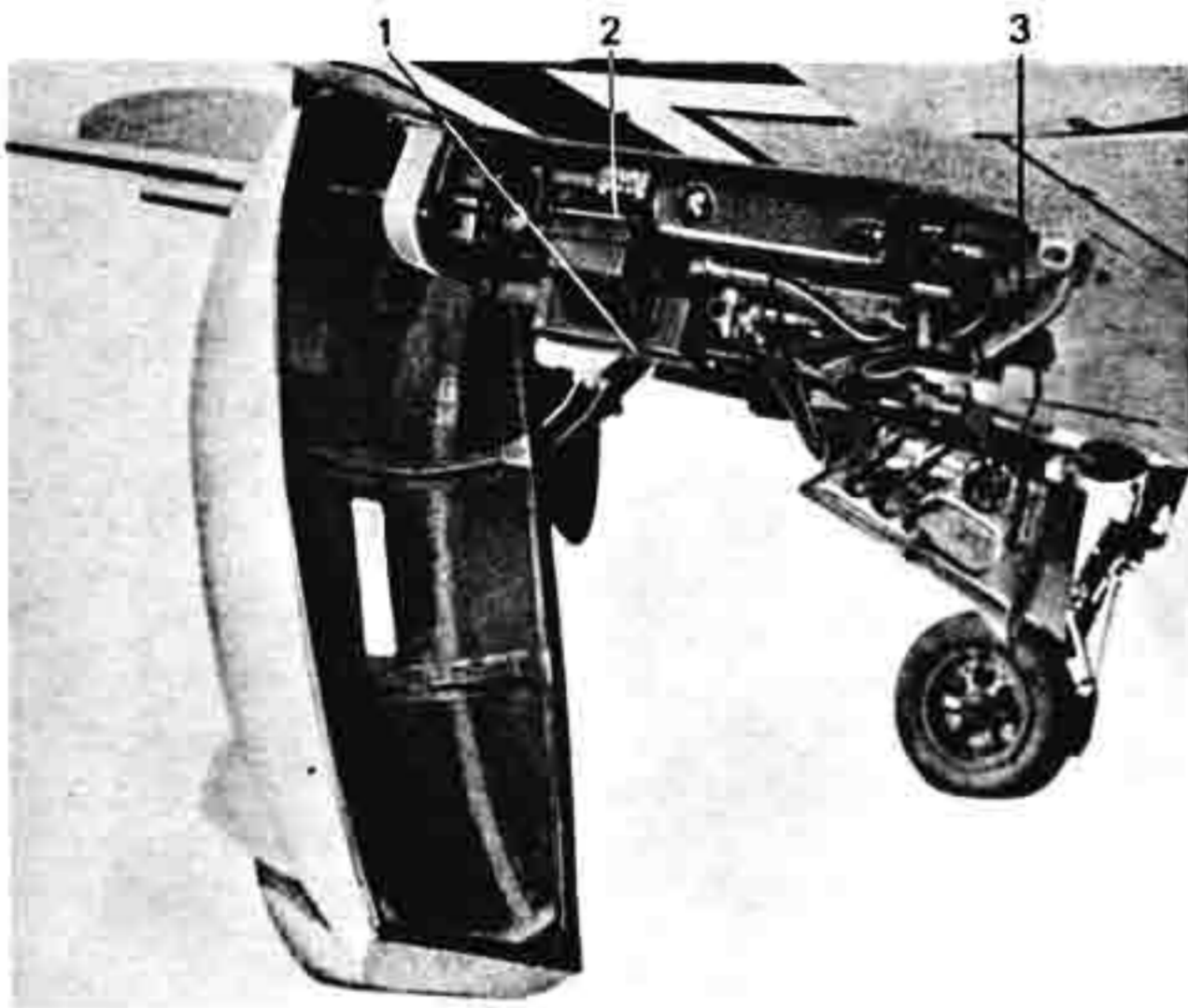

Fig. 2: SZKK-4

## VII. Camera installation

Provision has been made for the installation of a BSK 16 16mm movie camera in the wing leading edge, within the propeller arc (See Part 8E). The camera

can be triggered by the firing of the guns, or separately by a button on the throttle lever.



- 1. Link belt segment/cartridge casing chute
- 2. Link belt segment chute
- 3. Weapons carrier locking handle

Fig. 3: Twin gun pack in position; gondola down

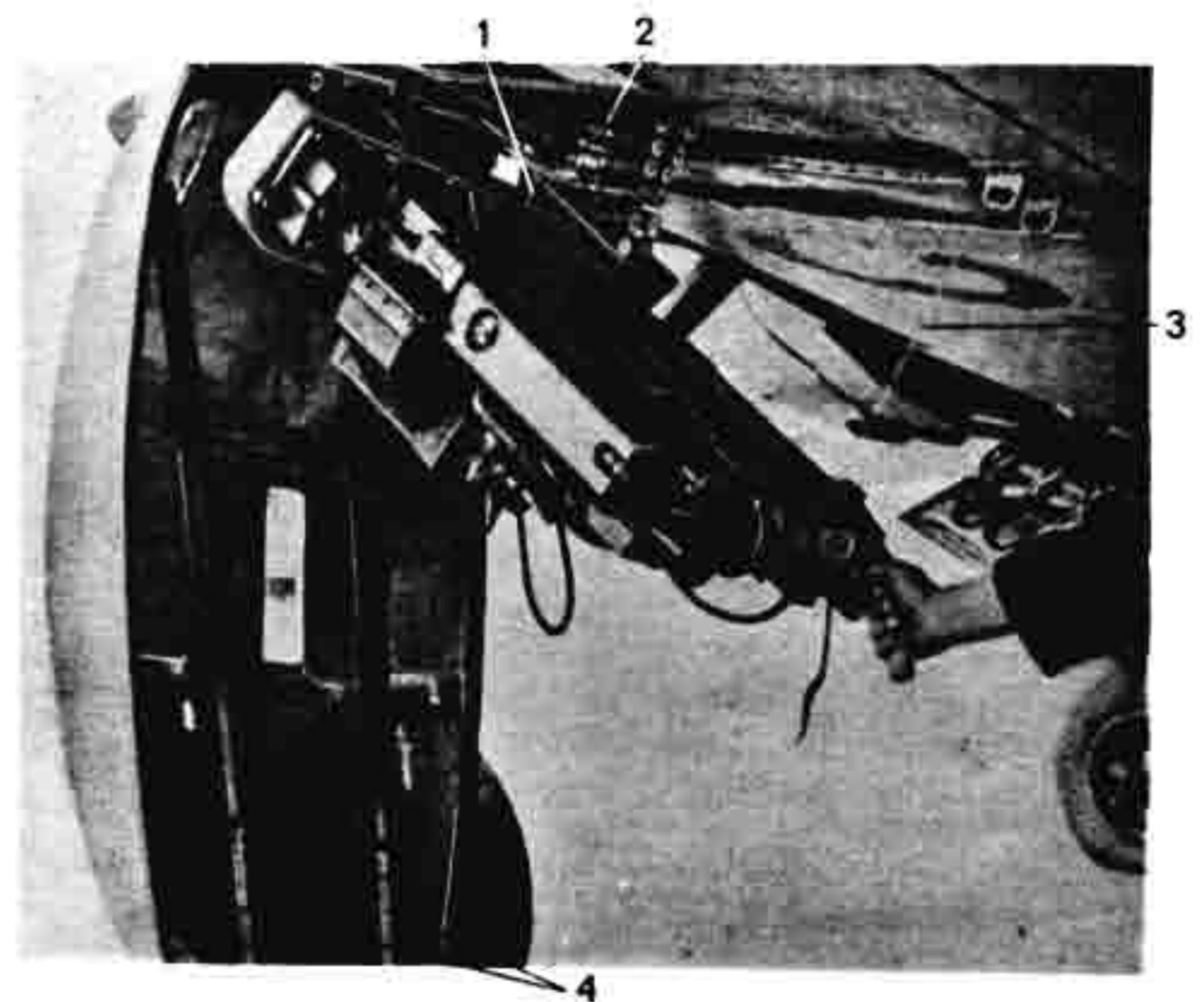

- 1. Ammunition feed chute
- 2. Ammunition belt
- 3. Carrier restraining cord
- 4. Cannon barrels

Fig. 4: Cannon pack being lowered; gun barrels secured in gondola

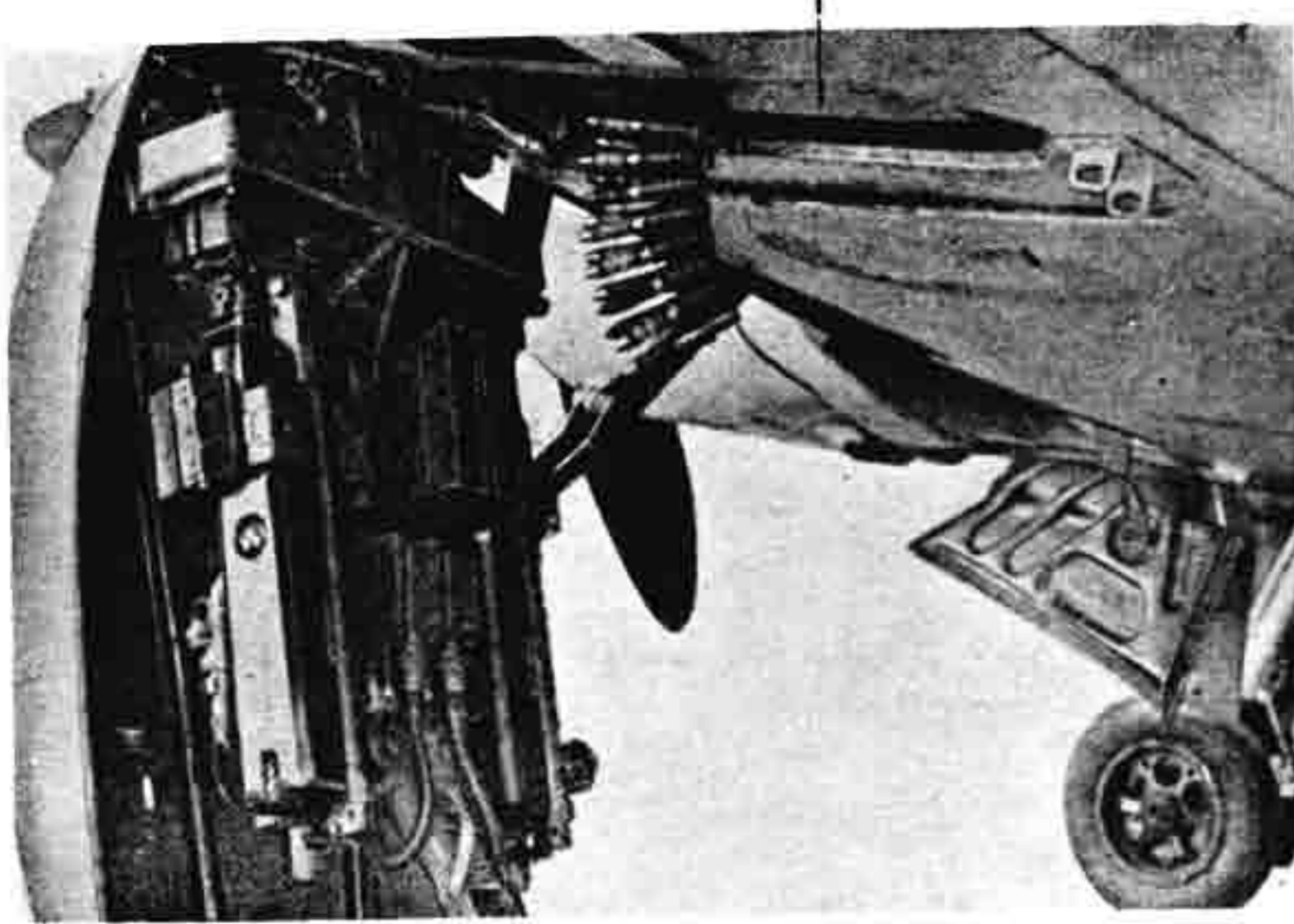

1. Ammunition box

Fig. 5: Cannon pack fully down

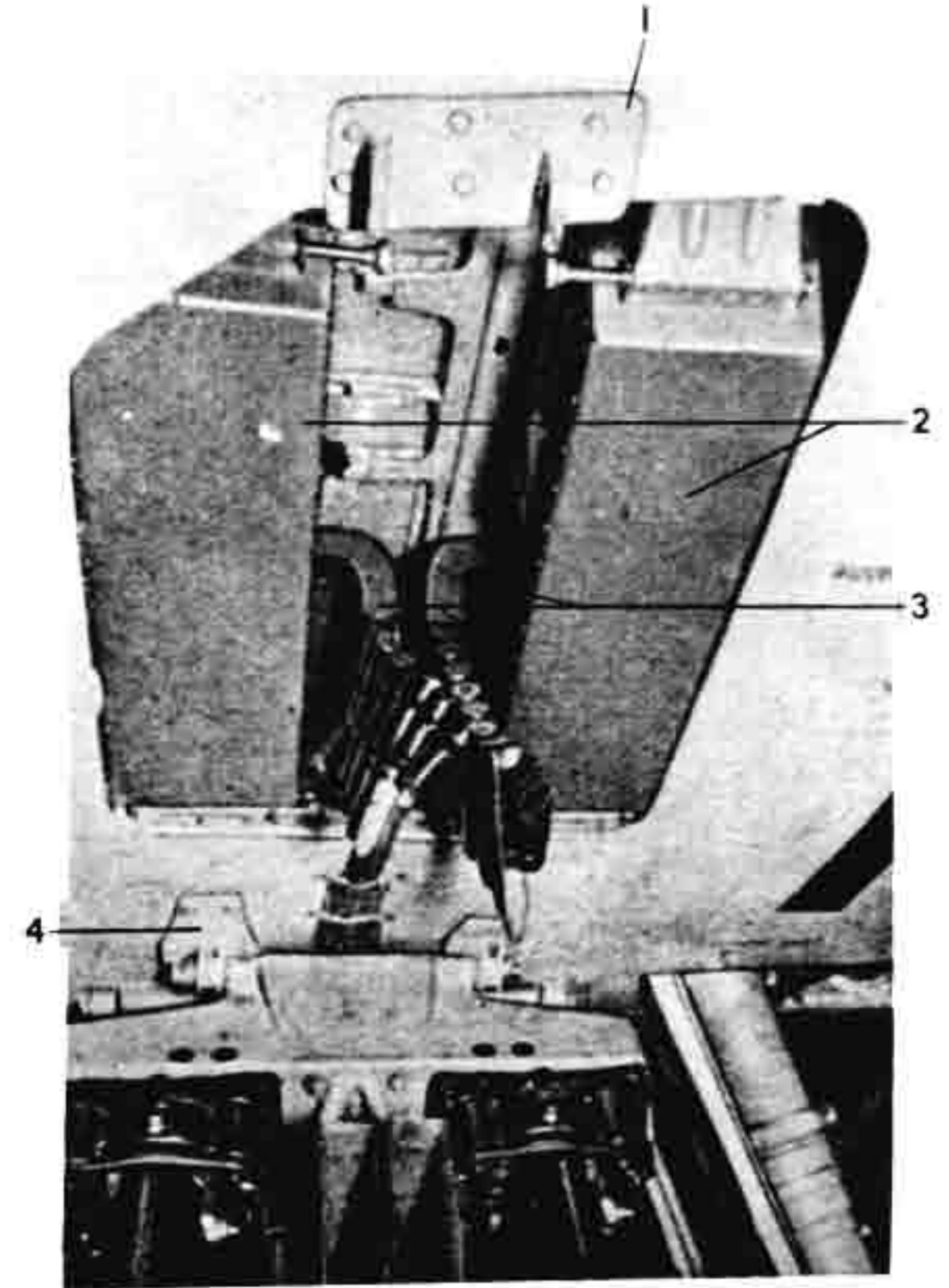

1. Carrier rear mounting point  
2. Ammunition boxes  
3. Ammunition feed chutes with belted ammunition  
4. Carrier forward mounting point

Fig. 7: Ammunition stowage area

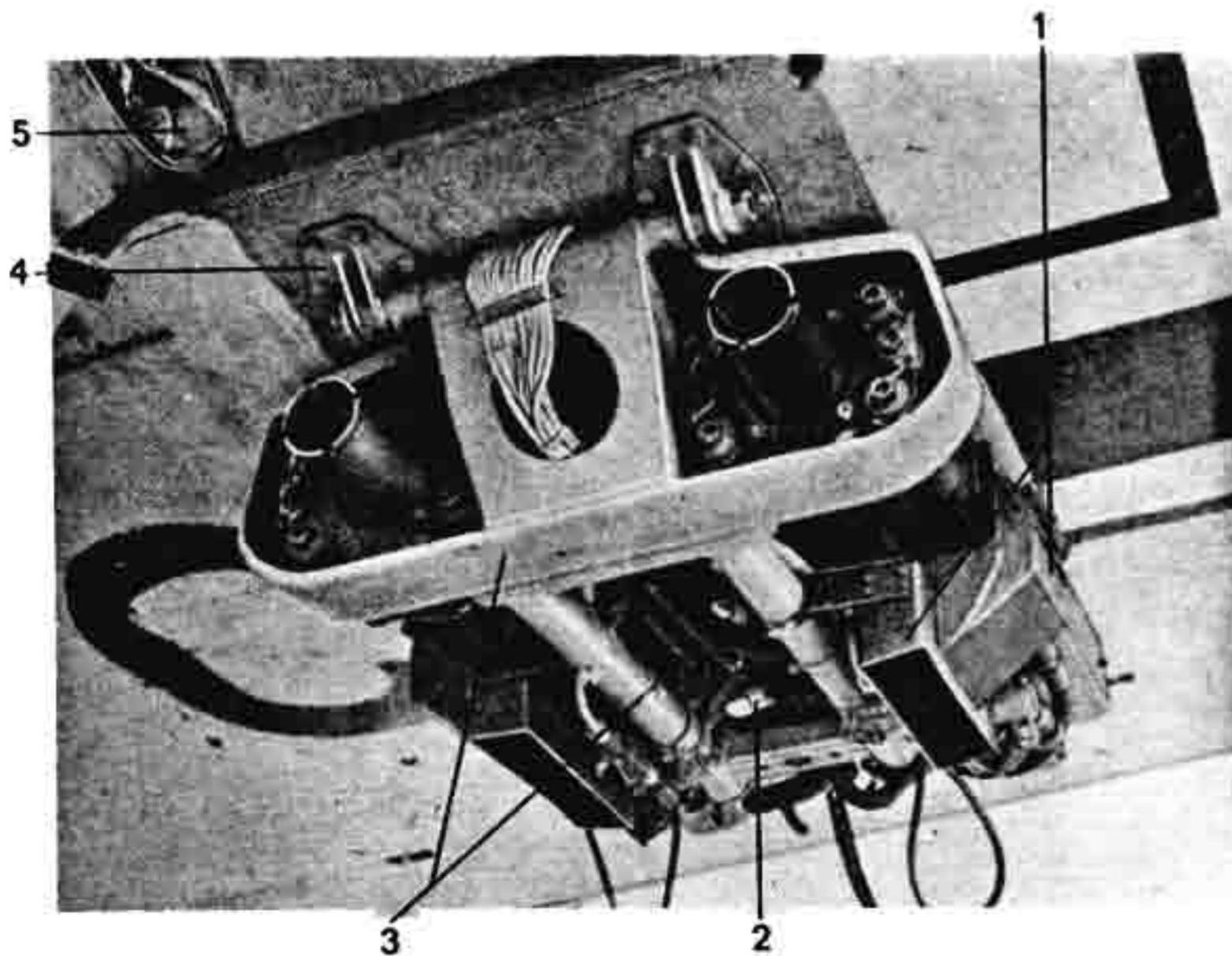

1. Link belt segment / cartridge casing chute  
2. Ammunition belt  
3. Carrier frame  
4. Carrier forward mounting point  
5. Cannon barrel protective cuff (in gondola)

Fig. 6: Gun pack in position; barrels removed

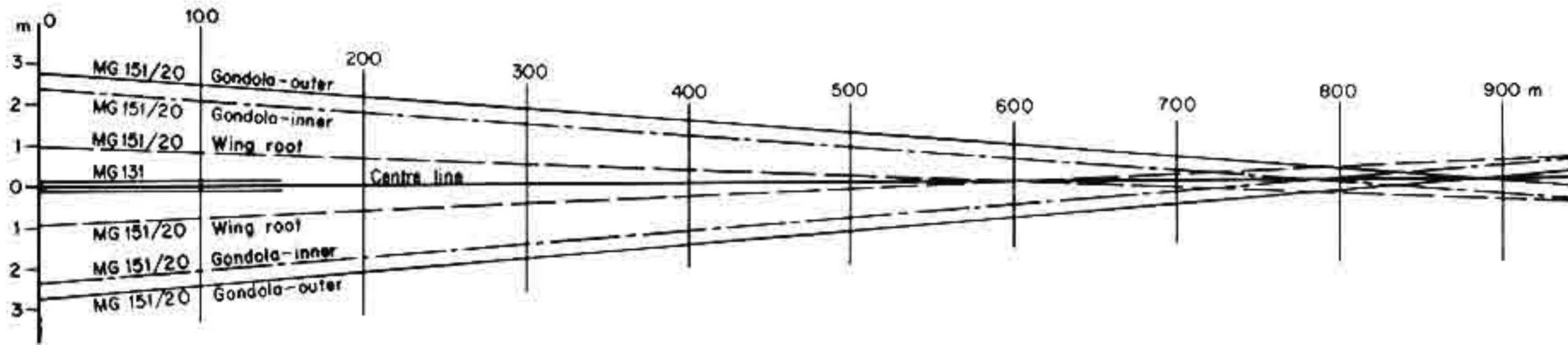
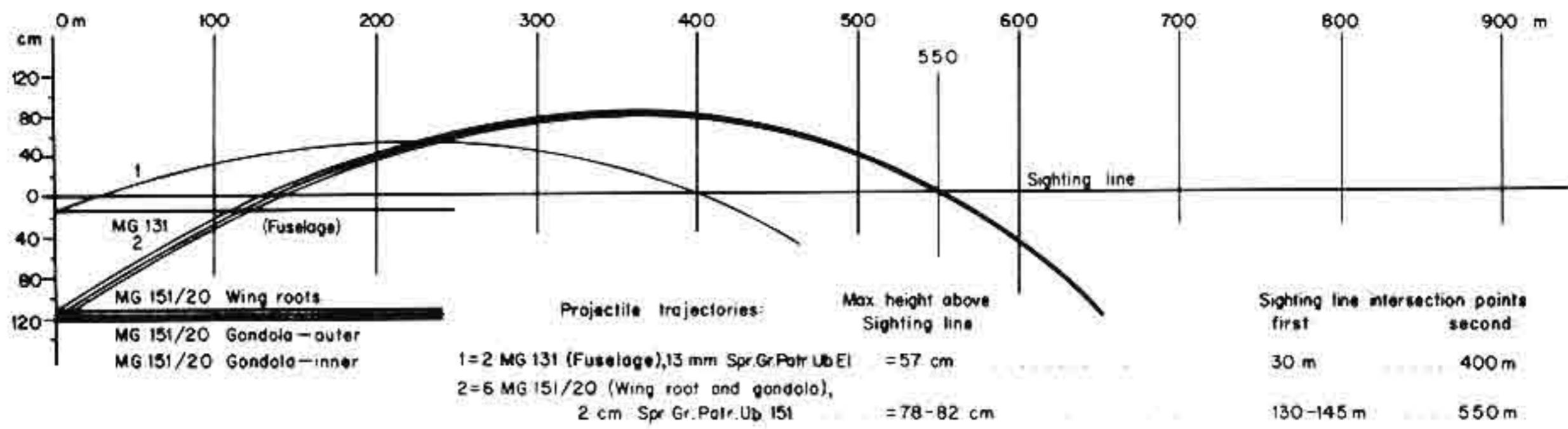

Annex A

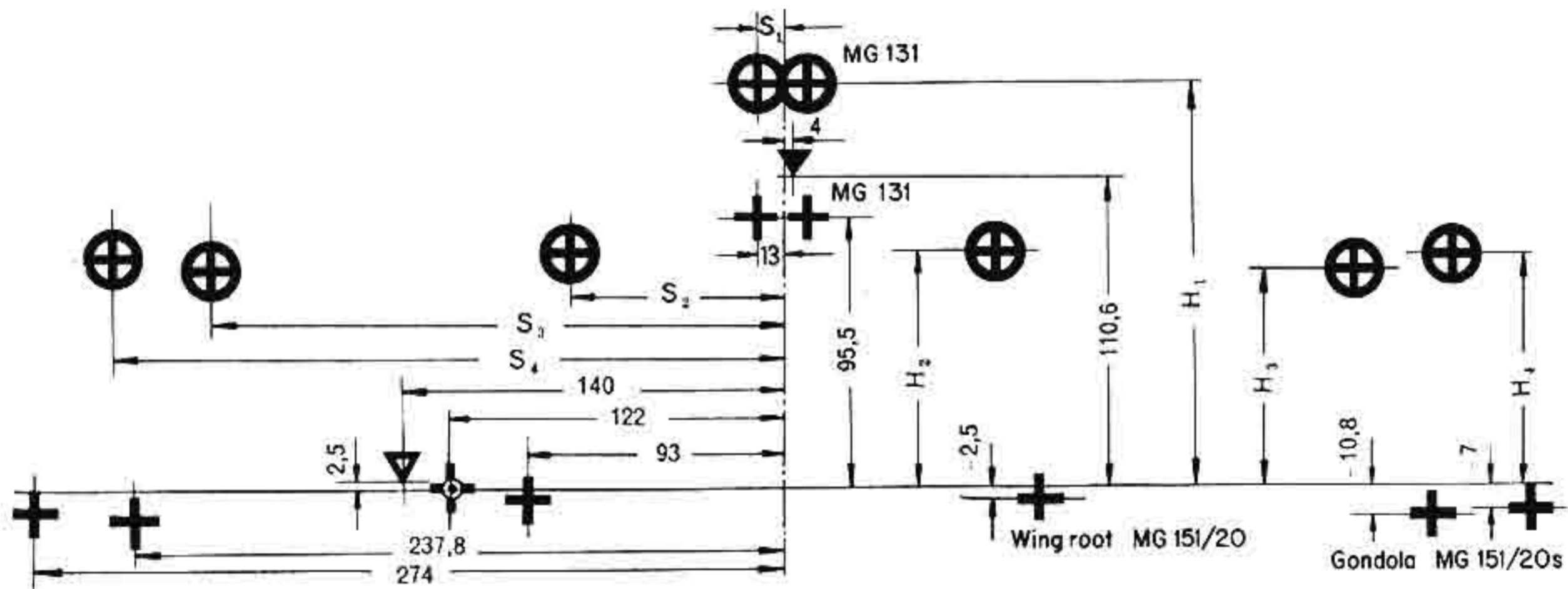

Weapons:

Fuselage: 2 MG 131  
Wing-roots: 2 MG 151/20  
Gondola, inner: 2 MG 151/20  
Gondola, outer: 2 MG 151/20

Alignment:

Harmonization 400m, Crossover: parallel  
Harmonization 550m, Crossover: 600m  
Harmonization 550m, Crossover: 800m  
Harmonization 550m, Crossover: 900m

Ammunition:

13mm Spr.Gr.Ub.El.  
2cm Spr.Gr.Patr.Ub.151  
2cm Spr.Gr.Patr.Ub.151  
2cm Spr.Gr.Patr.Ub.151

Gunfire strike table at 50m and 100m, in cm

Range	Fuselage 2 MG 131		Wing-root 2 MG 151/20		Gond., inner 2 MG 151/20		Gond., outer 2 MG 151/20	
	H <sub>1</sub>	S <sub>1</sub>	H <sub>2</sub>	S <sub>2</sub>	H <sub>3</sub>	S <sub>3</sub>	H <sub>4</sub>	S <sub>4</sub>
0m	95,5	13	-2,5	93	-10,8	237,8	-7	274
50m	121	13	44	85	37	223	41	258
100m	142	13	85	78	78	208	83	244

Annex B

D. (Luft) T. 2190 A-8

For Official Use Only!

# **Fw 190 A-8**

Aircraft Handbook

**Part 8B**

**Bomb release system**

**(Effective July 1944)**

**Issued September 1944**

## Description

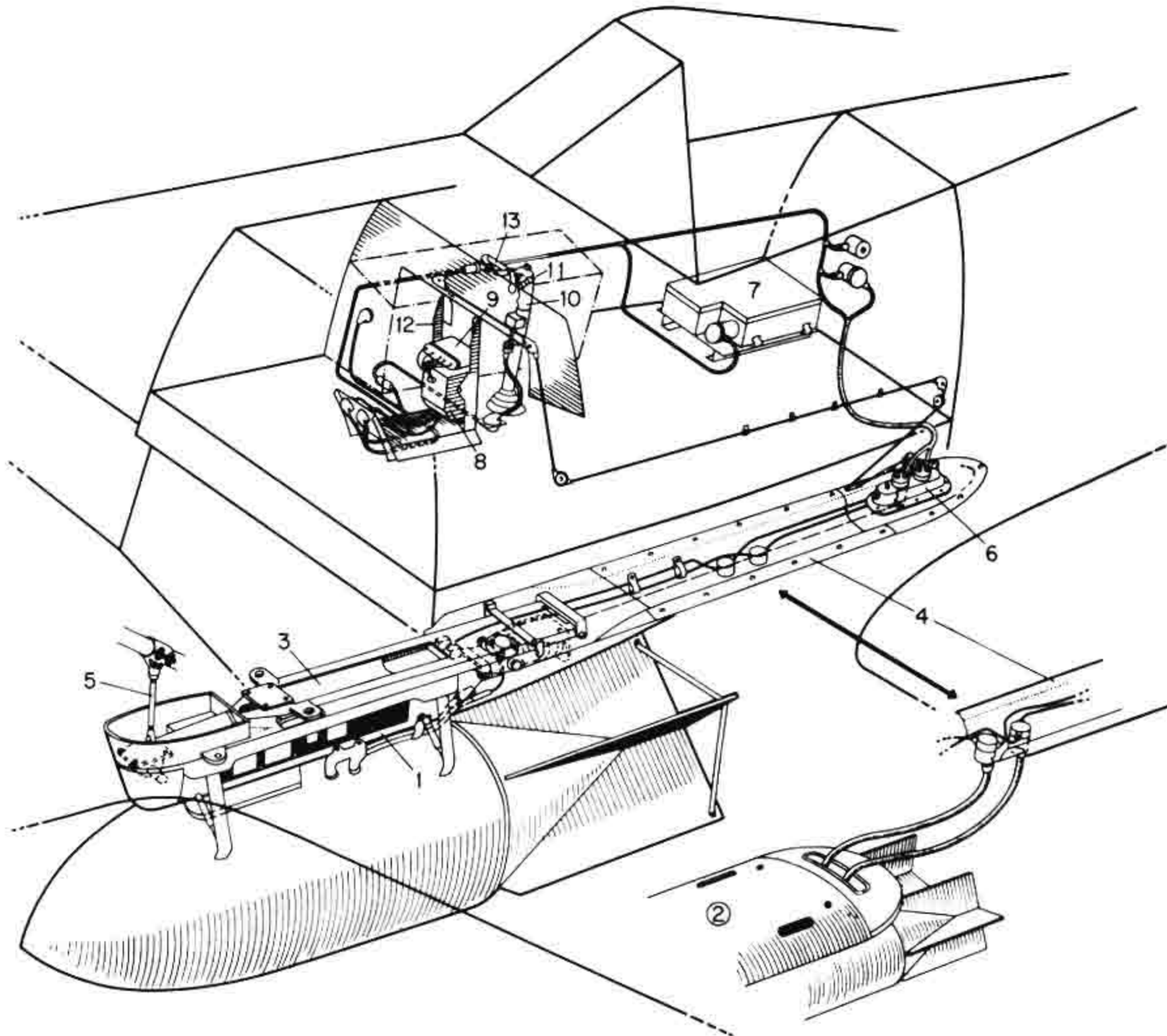

- |   |                                 |
|---|---------------------------------|
| 1 ETC 501                                   | 7 ZBK 241/1 fusing battery box  |
| 2 ER-4 adapter unit with<br>Type 50 release | 8 ZSK 244/A fusing selector box |
| 3 ETC 501 carrier unit                      | 9 Release indicator unit        |
| 4 Fairing                                   | 10 KG 13B control stick         |
| 5 Support                                   | 11 Bomb release button          |
| 6 Instrument trough                         | 12 Armament panel               |
|   | 13 Emergency release handle     |

Fig. 1: Bomb release system skematic

### General

The Fw 190A-8 differs from earlier A-series aircraft in that its ETC 501 carrier has been moved forward 200 mm (7.9 in). This repositioning has been made necessary by the building of an auxiliary fuel tank into the aircraft rear fuselage.

Simplifications have been made to the bomb release system within the A-8 production run. These are concerned primarily with the electrical release and monitoring circuits.

### A. Bomb release mechanism

To this belong:

- ETC 501 (1,1)
- ETC 501 carrier (1,3)
- Fairing (1,4)
- Armament panel (1,12)

The ETC 501, the ETC 501 carrier, and the fairing are fitted to the underside of the aircraft.

The armament panel is located between the auxiliary instrument panel and the cockpit floor.

## 1. ETC 501

The ETC 501 can be loaded with bombs or disposable carriers to a total weight of 500 kg (1102 lb); or with an ER-4 adapter unit for four bombs or disposable carriers, each of a maximum weight of 50 kg (110 lb).

A Type 500/XII release unit is fitted into the ETC 501.

The selector switch on the ER-4 adapter is to be set to the normal setting (single release).

A 300 Ltr (66.2 gal) drop tank can be fitted in place of bombs. For this, spacer bars must be attached to the ETC 501. These bars are not required when the E2 metal tank is fitted.

Two cotter-pin saftied bolts, one each through the forward and rear fittings, secure the ETC 501 to its carrier. During servicing, the carrier and ETC 501 are considered to comprise one unit.

### Note:

Before loading the bombs, ensure that full ammunition boxes for the MG 131s and the wing-root MG 151/20Es have been inserted, as this can only be done with the forward portion of the ETC 501 carrier swung down. To insert the MG 131 ammunition boxes, remove the wheel cover fairings and swing the link-belt segment and cartridge casing chute on the engine lower support frame forward.

## 2. ETC 501 carrier unit

The carrier (Fig. 2) is of a special design to hold the ETC 501.

The ETC 501 is secured to its carrier by: a forward fitting (2,2), and by a rear fitting (2,3). Tightening the set screws (2,8) within the upper mounting plates (2,4) secures the ETC 501 carrier; tightening the set screws (2,9) within the lower mounting plates (2,5) secures the ETC 501. The attachment of the carrier unit to the fuselage mounting points (the forward mounting point is on the main spar, the rear mounting point on Bulkhead 4, and a stabilizing strut mounting point on the engine lower support strut) is accomplished by two bolts and a strut. The forward, spring-loaded, bolt is fitted with an engaging lever (2,6) and is locked by rotation of that lever; the rear bolt is secured by a cotter pin; and, the stabilizing strut is attached by a screw-on collar.

The rear end of the carrier unit is forked and secured to a fitting on Bulkhead 4 (carrier rear suspension point).

To the underside of the carrier rear segment is fixed, in an accessible position, an E55 electric motor which drives the EP-1E drop tank fuel pump.

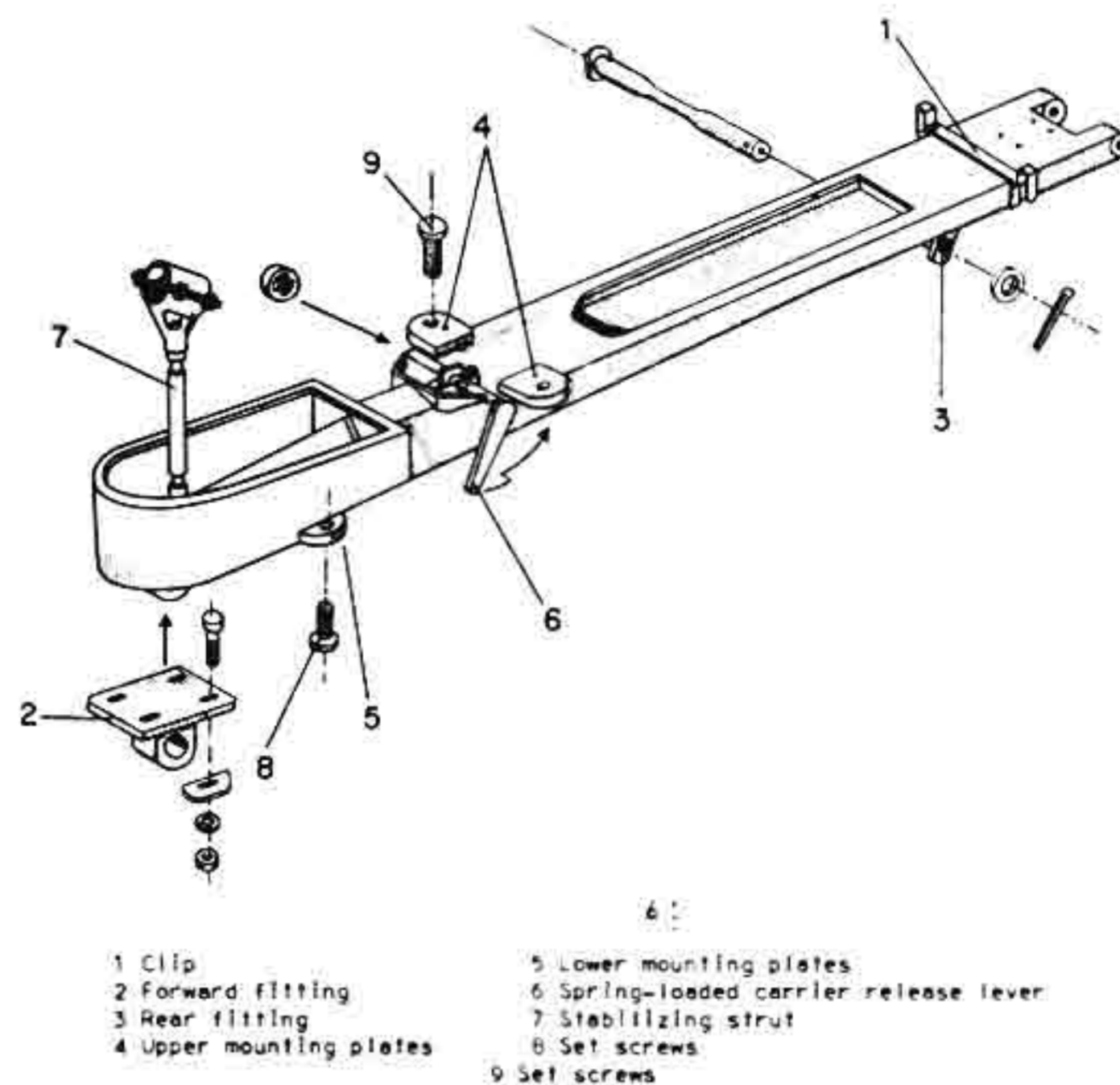

Fig. 2: ETC 501 carrier unit

## 3. Fairing

The fairing consists of the following three parts:  
 Forward portion (3,1)  
 Centre portion (3,2)  
 Rear portion (3,3)

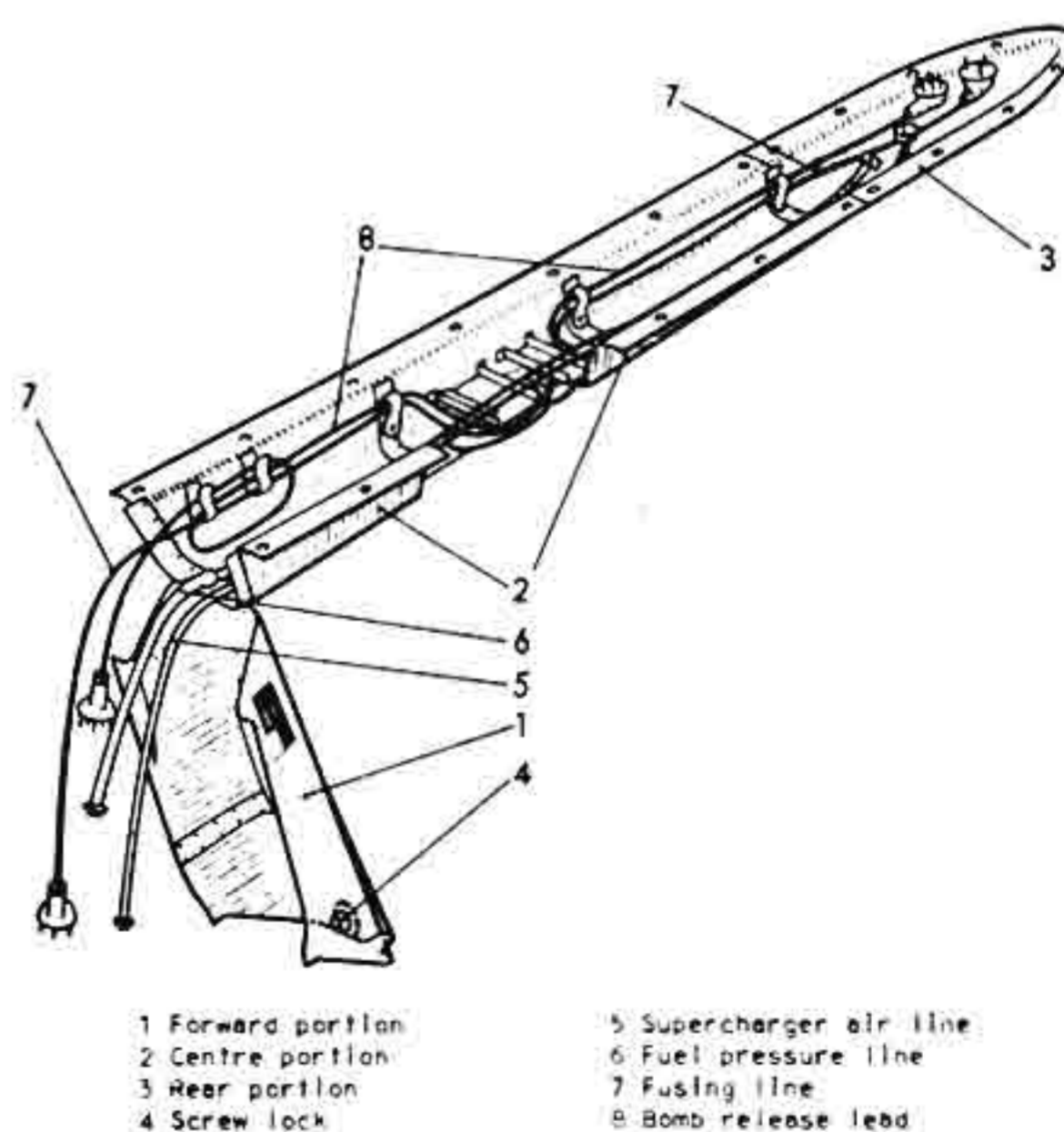

Fig. 3: Fairing

It is attached to the fuselage bottom with countersunk screws. The forward and centre portions (3,1 & 2) are joined by a hinge; the forward portion being secured to the ETC 501 by a screw lock (3,4).

The lines (3,5-8) which lie within the fairing centre portion connect the aircraft systems to the ETC 501 carrier and thus to the equipment on the ETC 501.

#### 4. Armament panel

The armament panel (4,1) contains the ZSK 244A bomb fusing selection box (4,2) and the SAM 77 Fw 74 release indicator lights (4,3). It is situated between the auxiliary instrument panel and the cockpit floor, and is connected to these by screws.

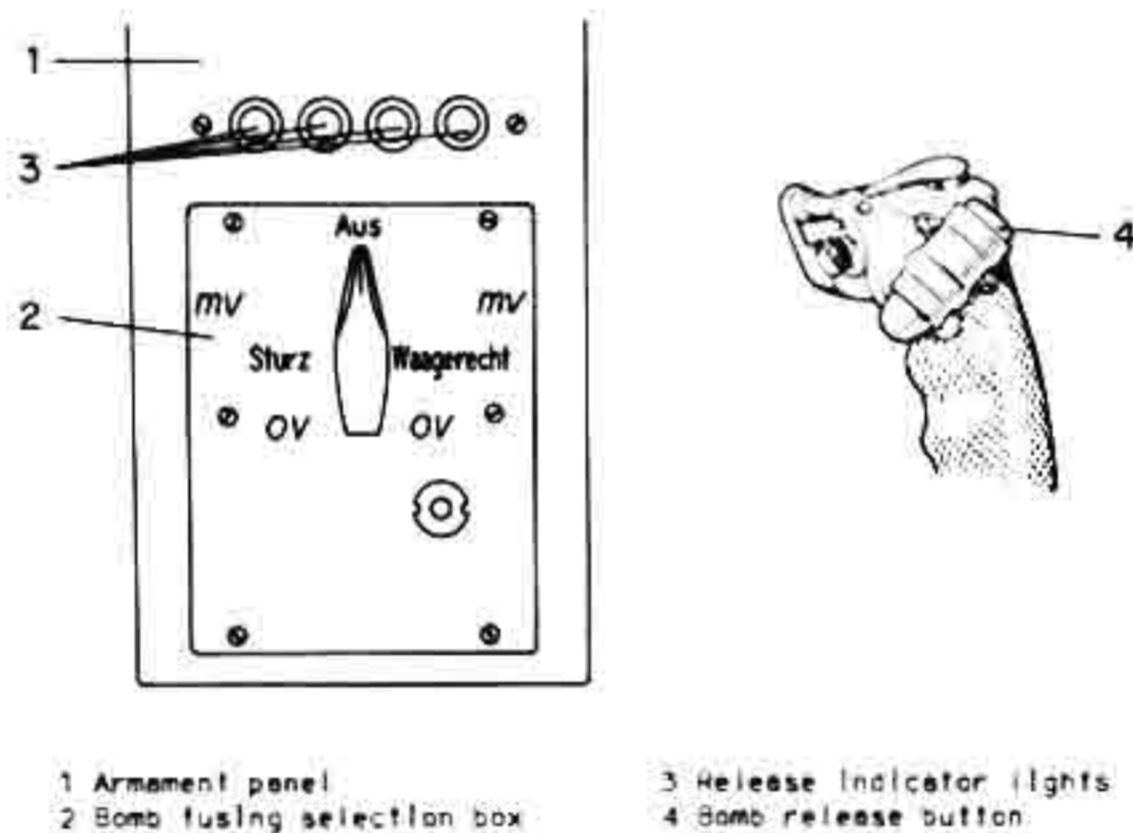

Fig. 4: Armament panel

### B. Release and monitoring circuits

This circuit is used for the release and monitoring of the bomb release system. It consists of the following units:

- 1 ZSK 244A fusing selector box
- 1 SAM 77 Fw 74 indicator unit
- 1 bomb release button

The ZSK acts as the main switch for the electrical release unit.

The indicator unit is secured to the armament panel by two screws. When a 250 kg or 500 kg bomb is carried, only the right hand indicator light is connected into the fusing selector box circuit. When the ER-4 adapter release units (4 ETC 50/XIII) are loaded the three other indicator lights are also connected into the fusing circuit. After a bomb is released, the appropriate indicator light illuminates.

The bomb release B2-button (4,4) is located on the KG 13B control grip.

The system is connected into the aircraft circuit by depressing circuit breaker V50 on the right instrument console.

### C. Sighting device

The Revi 16B is used as the sighting device for the bombing system; it is more fully discussed in Part 8A.

### D. Emergency bomb release

Pulling the emergency bomb release handle (1,13)—release force  $\geq 30$  kg (with movement of at least 24 mm)—labelled "Bomben" causes the jettison of any load being carried on the ETC 501. When the ER-4 adapter (1,2) is mounted, an emergency release of the individual loads is not possible, in fact, during emergency release the adapter itself is dropped; in this event, the fusing and release lead plugs are torn out.

Note! Bombs loaded on the ER-4 adapter, when released manually, fall safetied even if the ZSK has been switched on. Bombs loaded directly onto the ETC 501, will fall armed if the ZSK has been switched on.

### E. System removal

If the aircraft is to be flown without the bomb release system, the ETC 501 carrier, with integral ETC 501, fairing and Bulkhead 4 suspension fittings must be removed. In the same way, the electrical leads, the fuel line leads, the air pressure lines, and the emergency release cable to the underfuselage trough (1,6) are no longer necessary. A streamlined cap to fair in the forward mounting points on the main spar, and a plate to cover the opening for the underfuselage trough are provided in the aircraft equipment bag.

Since, when the ETC 501 carrier unit is attached, the undercarriage wheel covers cannot open or close properly, the wheel covers are exchanged for fixed fairings when the ETC 501 rack is installed. These fixed fairings cover a small portion of the underfuselage apertures in the same manner as do the wheel doors. In that case, the undercarriage fairings are lengthened.

For operations without the bomb release mechanism, the fixed fairing plates are traded for the wheel door units, and the lengthening segments are unscrewed from the undercarriage lower fairings.



D. (Luft) T. 2190 A-8

For Official Use Only!

# **Fw 190 A-8**

Aircraft Handbook

**Part 8C**

**Special weapons system**

**(Effective July 1944)**

**Issued September 1944**



## Description

### A. General

The Fw 190A-8 is outfitted to carry the 21-cm BR weapons system.

The 21-cm BR unit serves to fire a spin stabilized projectile, the 21-cm Type 42 mortar shell (Information concerning the weapon is contained in the following two publications, H.Dv. 481/62 and H.Dv. 119/984). As aimed fire with this weapon is not possible, it can only be feasibly used against large targets (enemy bomber formations). The projectile is

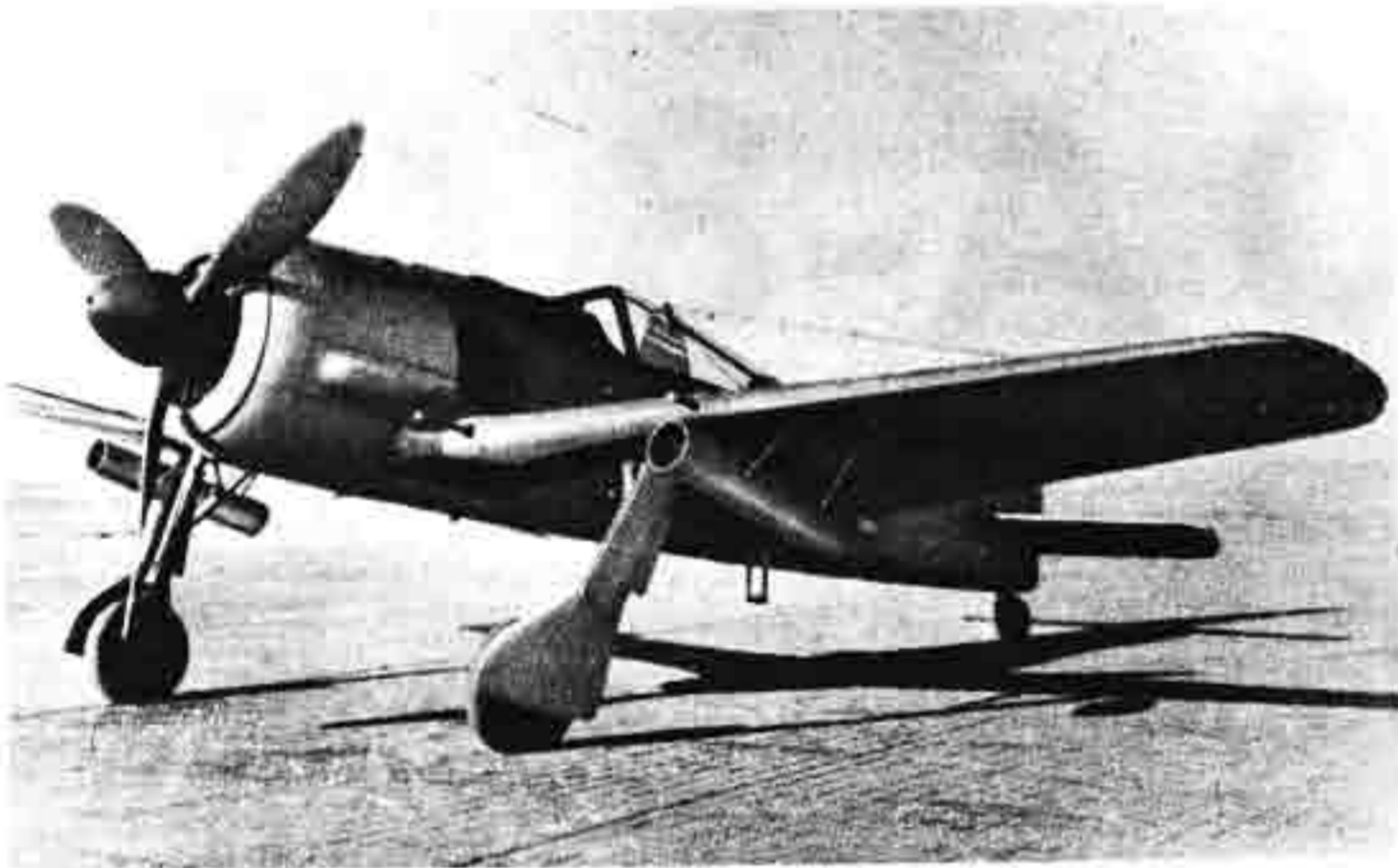

Fig. 1\*: Fw 190 with 21-cm BR system

fired from a launching tube (2,1), one of which is located beneath each wing panel. Each launching tube is suspended by a carrier strut (2,4), from a hook (2,2) fixed to the wing lower surface; and is locked into position by four bracing struts (2,3). In an emergency, the launching tube can be jettisoned by severing the carrier strut. The two projectiles are fired simultaneously by depressing the B2-button on the KG 138 control grip.

### B. Equipment

#### 1. Launching tube

The launcher consists of a tube (3,1) 1,3 m (51.2 in) long and of 210 mm (8.32 in) calibre. To the inner surface of the tube are attached—at 120° intervals—three guide rails (3,2). Three retaining springs, located near the rear end of the tube, hold the shell in place; a screw bolt (3,3), at its lower rear end, prevents the weapon from sliding out; and, a spring-loaded contact (6,3), at its upper rear end, fires the weapon.

The bracing strut lower studs (3,5) fit into bracing

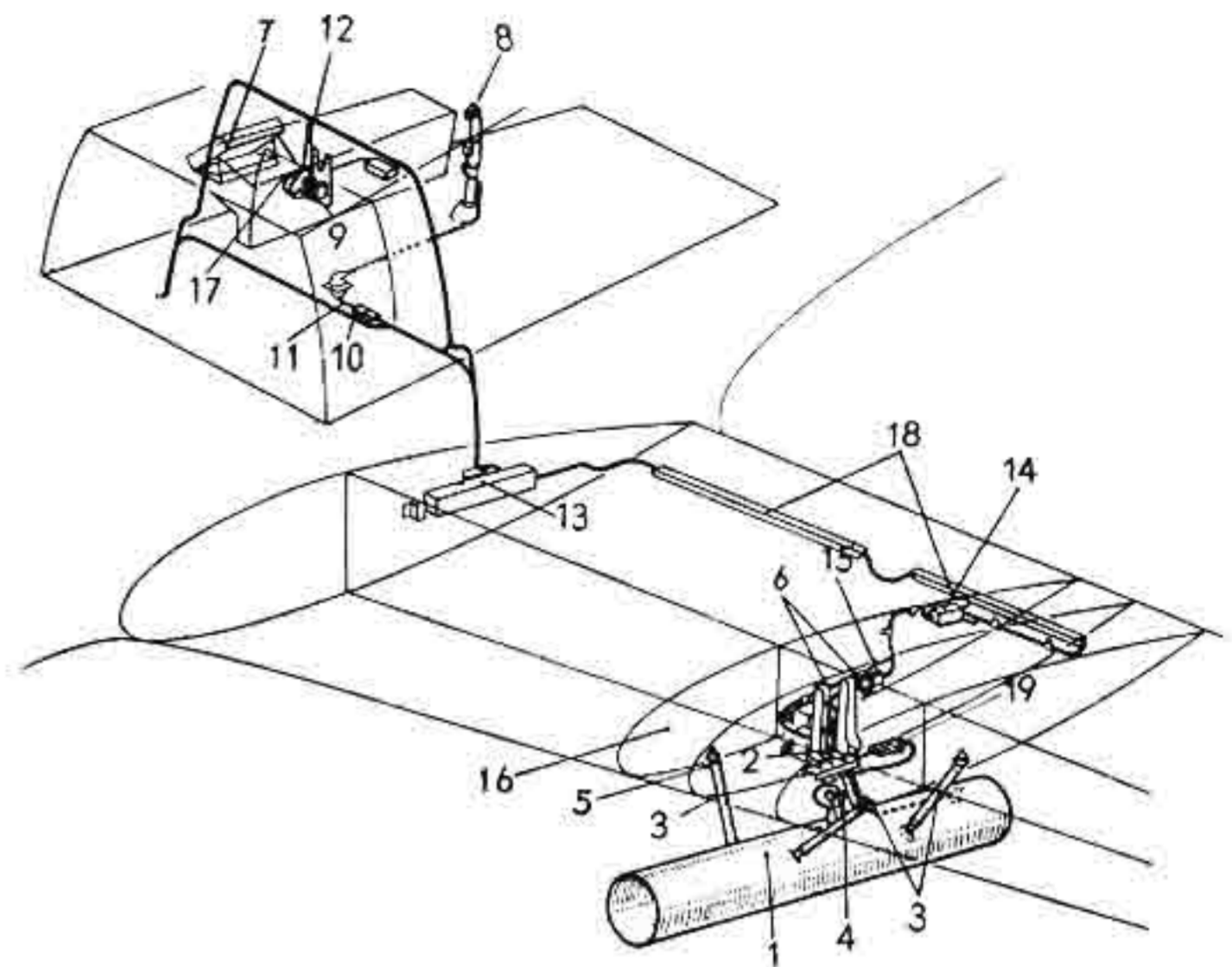

- |  |                             |
|--|-----------------------------|
| 1 Launching tube                       | 10 Connector jack P803      |
| 2 Hook with suspension bracket         | 11 Electrical plug R8       |
| 3 Bracing struts                       | 12 Armament panel           |
| 4 Firing tube carrier strut            | 13 Wing separator point     |
| 5 Centre rib 8                         | 14 Circuit relay            |
| 6 Support brackets                     | 15 Plug connector P812/P813 |
| 7 SVX 2-151/131E fuse and junction box | 16 Centre rib 7             |
| 8 KG 138 control stick                 | 17 Armament switch P801     |
| 9 Armament switch P802                 | 18 Conduit                  |
|  | 19 Plug connector P814/P815 |

Fig. 2: System skematic

lugs (3,4) welded to the upper portion of the launching tube. The tube hangs beneath the outboard weapons bay, suspended from a hook (3,7) which is secured to Centre rib 8 (2,5) by two screws and

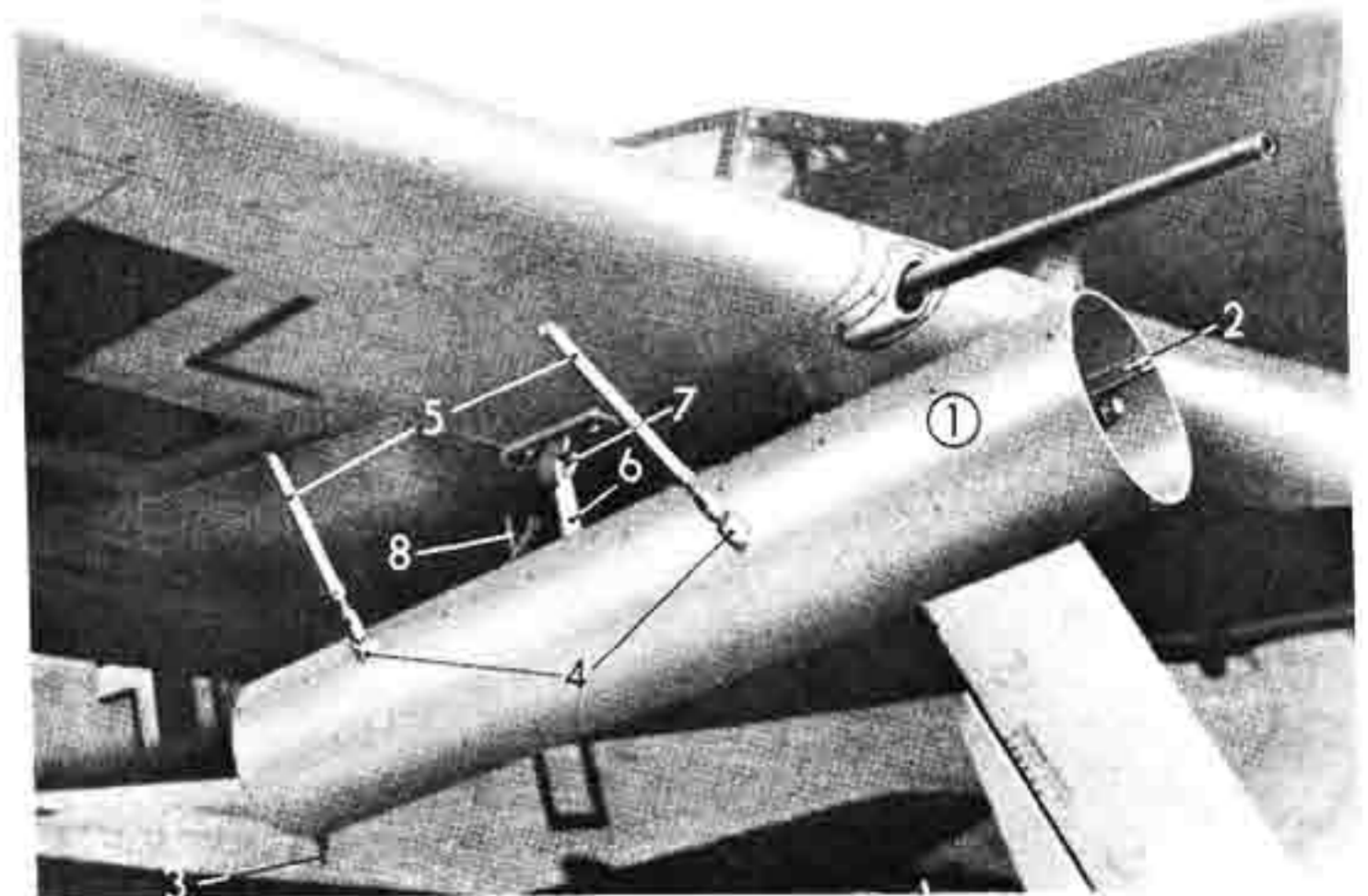

- |                  |                                |
|------------------|--------------------------------|
| 1 Launching tube | 5 Bracing struts               |
| 2 Guide rail     | 6 Carrier strut                |
| 3 Screw bolt     | 7 Hook with suspension bracket |
| 4 Bracing lugs   | 8 Firing lugs                  |

Fig. 3: Launching tube beneath right wing panel

crown nuts (safetied by cotter pins). Two support brackets (2,6), attached to Centre rib 8 at this point, serve to strengthen the mounting area. The launching tube is elevated 7° relative to the fuselage longitudinal axis.

### 2. Bracing struts

To lock the launching tube into position, the upper studs (4,3) of the four bracing struts are fitted into the wing lower skin through suitable holes or rimmed bushings. The length of each strut can be changed by rotation of the lower stud (4,1), and it can be locked in length by tightening the lock nut (4,5) against the strut collar (4,4).

The rounded ends of the lower studs (4,1) are inserted into the tube bracing lugs.

The strut tube (4,2) is 230 mm (9 in) long. The overall lengths of the forward and rear struts are as shown in Fig. 4.

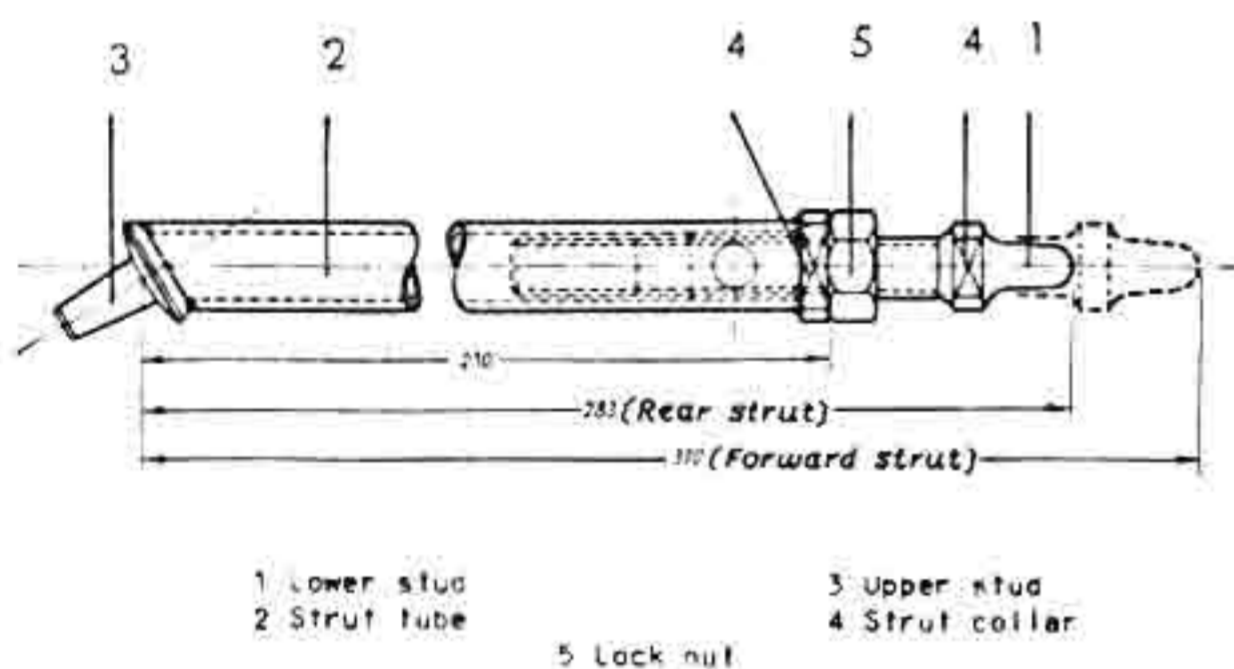

Fig. 4: Bracing strut

### 3. Release strut

The carrier strut (release strut) contains an electrically primed explosive charge which, in an emergency, severs it and so releases the launching tube.

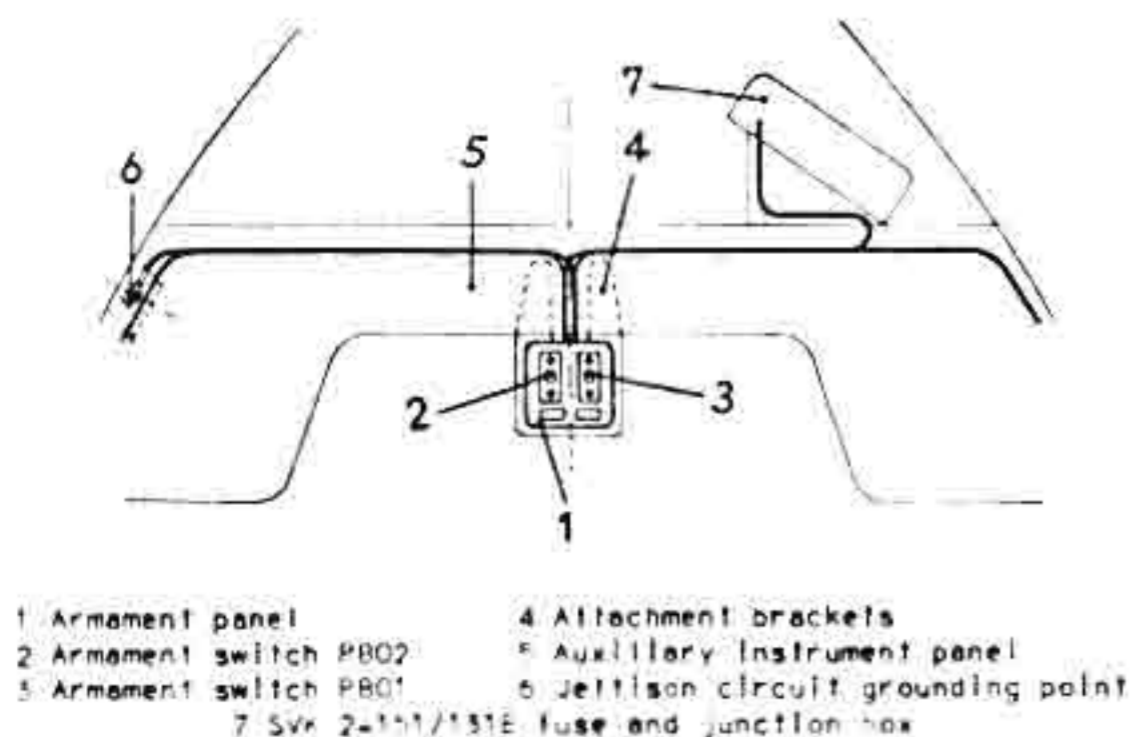

Fig. 5: Armament switch layout

### 4. BR-armament panel

The BR-armament panel (5,1) contains two armament switches (5,2 & 3). This panel is attached to the auxiliary instrument panel (5,5) by two brackets (5,4).

### C. Sighting device

The Revi 16B reflector sight (see D. (Luft) T.6403), serves as the sighting device for this system. After notification by a TAGTT, it will, at the appropriate time, be replaced by the Revi 16F.

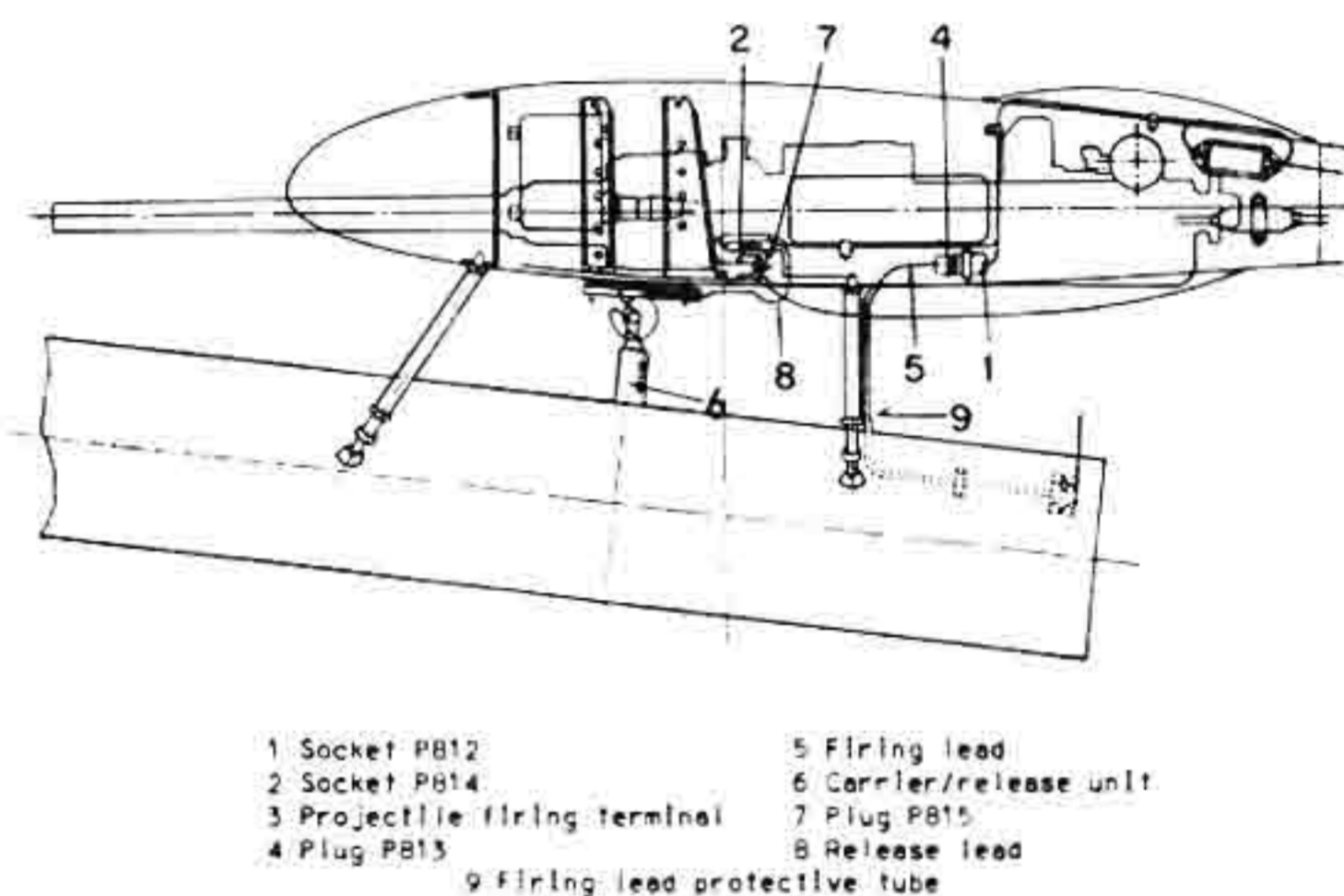

Fig. 6: 21-cm BR system side view

The field of vision through the Revi view finder must be at least 7,5° in all directions from the sighting line.

### D. Control system

The control system consists of the electrical firing and release circuits. The firing circuit is used to fire the projectiles while the release circuit jettisons the launching tubes.

#### Operation

##### a. Firing

Complete the firing circuit by activating circuit breaker P1 (right instrument console), Safety switch I (SZKK4 control unit), and toggle switch P802 (marked "Sicherheitsschalter Gerät 21" and located on the left side of the BR armament panel). To fire the shells, depress the bomb release button, B2, located

on the upper left side of the control grip.



Fig. 7: KG 13B with B2 firing button

b. Release

In an emergency, the launching tubes can be released by severing the carrier struts with explosive charges. Circuit breaker P1 and Safety switch I complete the release circuit. To fire the charges, actuate toggle switch P801 (marked "Absprengung Gerät 21" and located on the right side of the BR armament panel). To prevent accidental actuation of the toggle switch, it is held in the safe position by a spring-loaded plate.

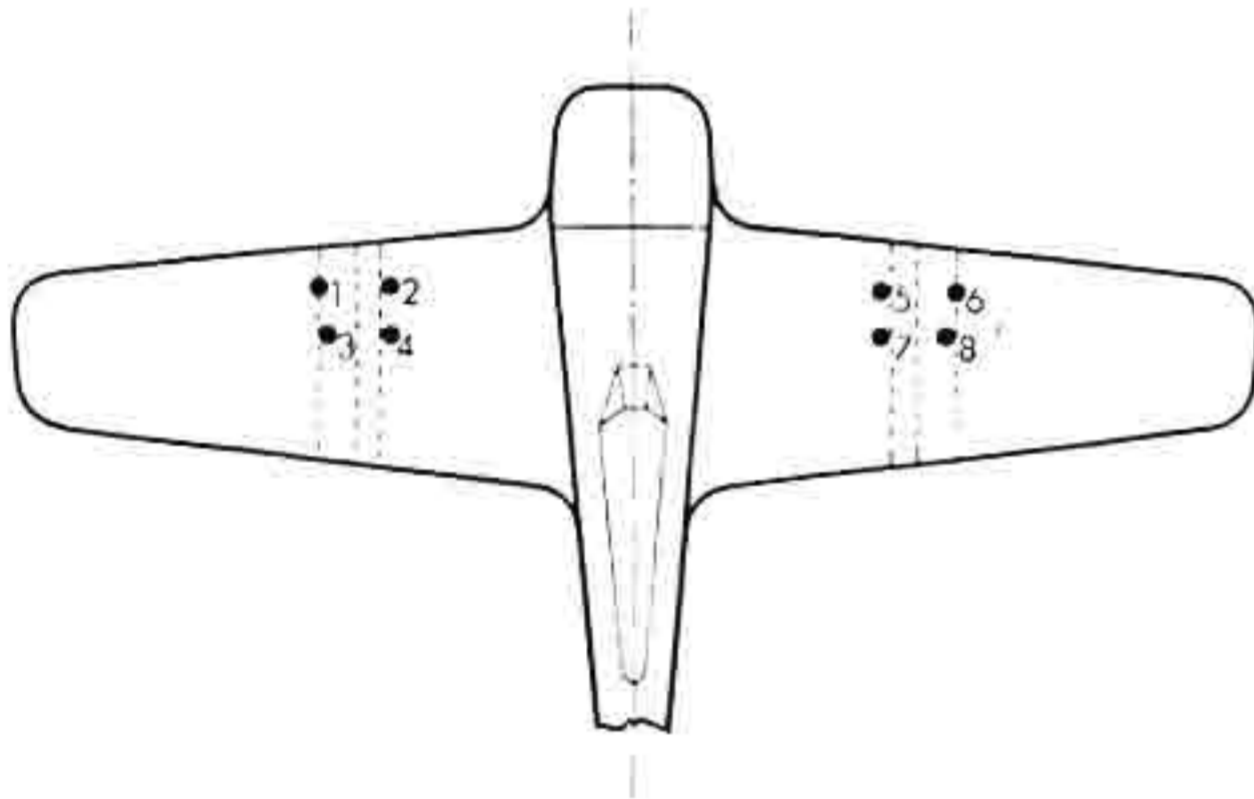

Fig. 8: Positioning of the bracing struts



D.(Luft) T. 2190 A-8

For Official Use Only!

# **Fw 190 A-8**

Aircraft Handbook

**Part 8D**

**Special fittings**

**(Effective July 1944)**

**Issued September 1944**

## General

'Special fittings' specifies the aircraft armour.

The armour protects the pilot, the oil cooler and the circular oil tank. Its positioning within the aircraft is as shown in Fig. 1.

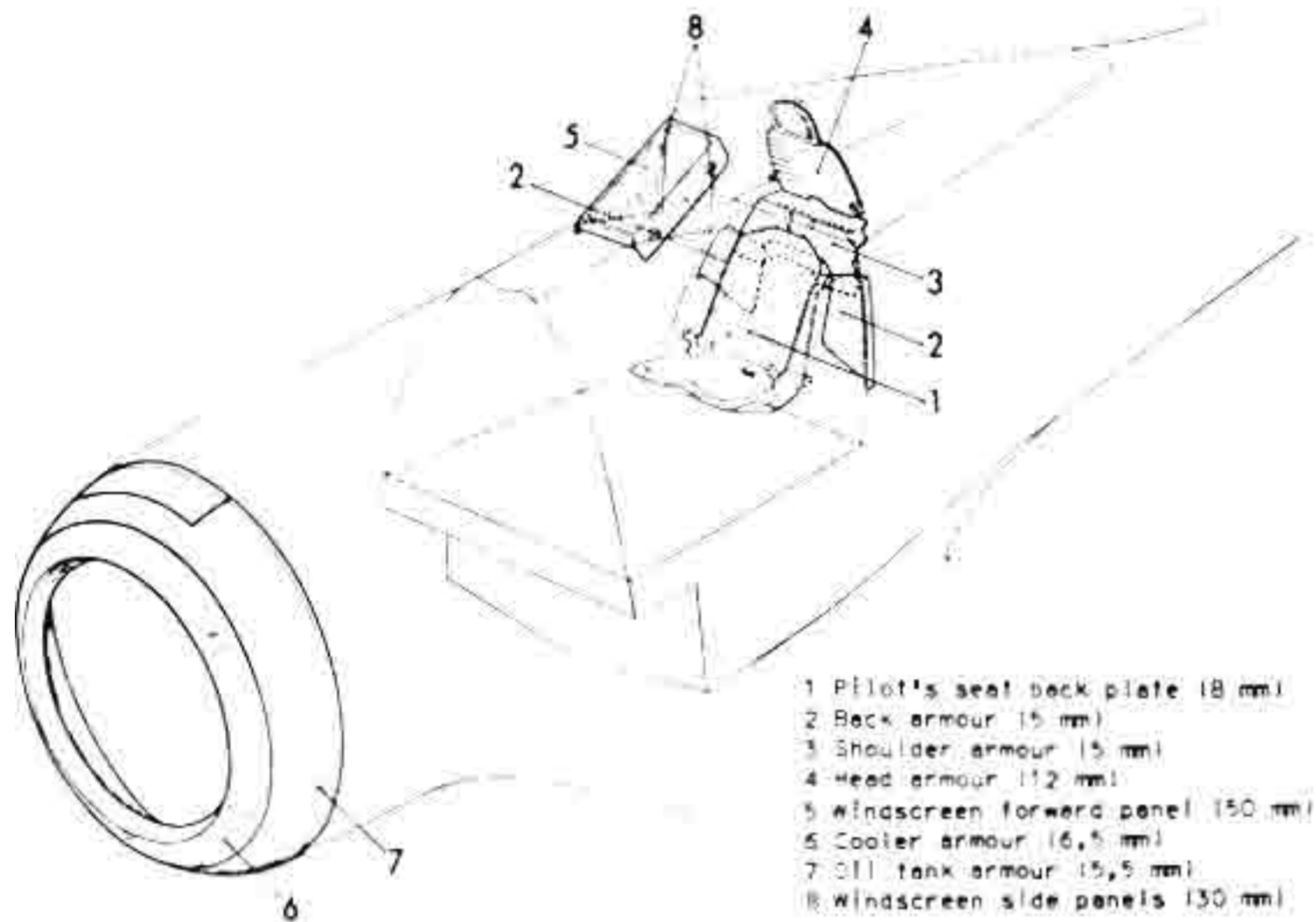

Fig. 1: Aircraft armour layout

### A. Cockpit armour

The cockpit armour consists of the back plate (1,1) on the pilot's seat, two back plates (1,2), a shoulder plate (1,3), and a head plate (1,4).

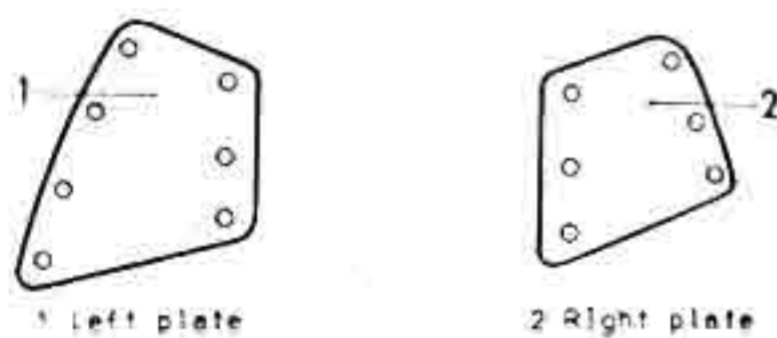

Fig. 2: Back armour, seen in direction of flight

Protection against gunfire is also provided:

- from the front: by the bullet resistant windscreen (1,5);
- from the sides: by bullet resistant glass panels (1,8) on either side of the forward windscreen panel; and,
- from below: by the two fuselage self-sealing fuel tanks.

The seat rear plate and seat pan are riveted

together.

The back armour consists of two separate plates whose inner edges are screwed to the seat guide rails, and whose outer edges are screwed to angle pieces in the fuselage walls. Nuts are riveted to the guide rails and the angle pieces; the plates are fastened from the rear by screws.

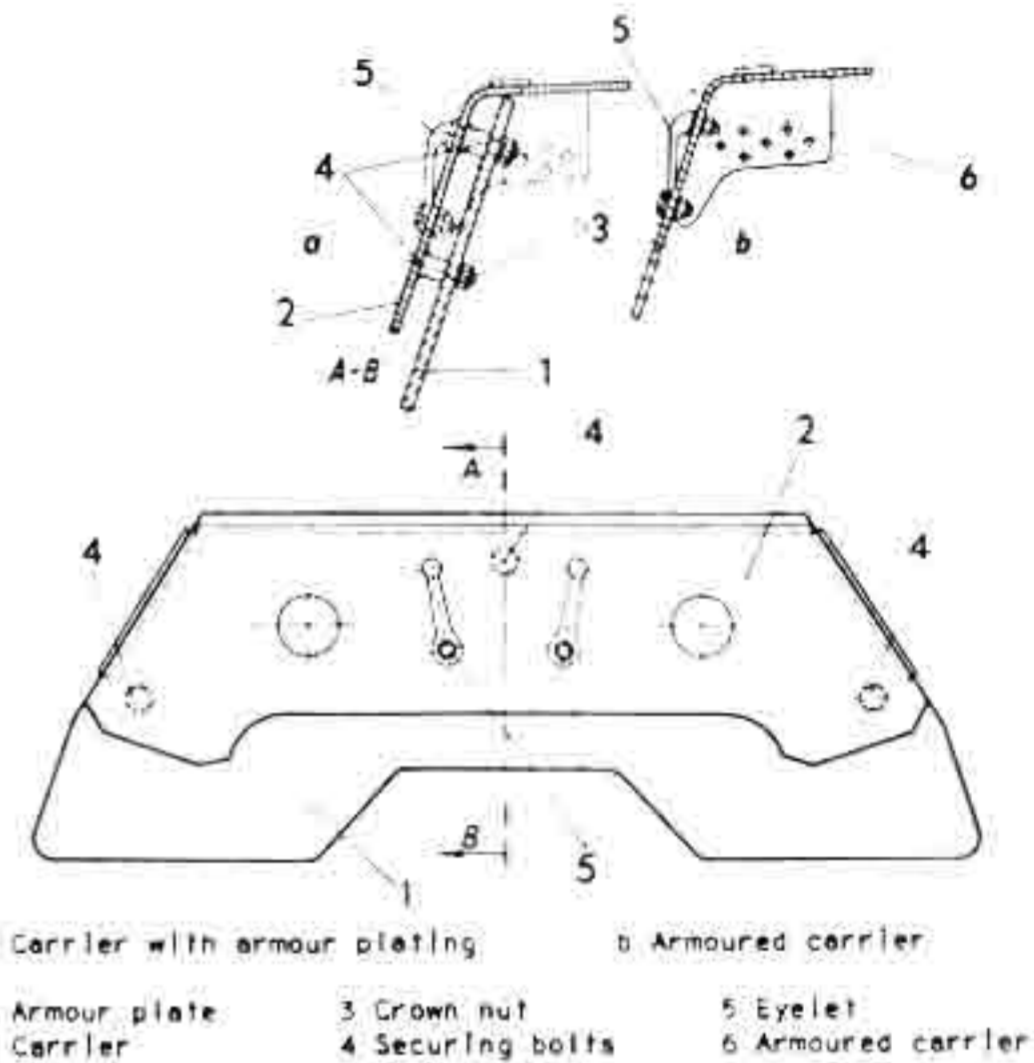

Fig. 3: Shoulder armour

The shoulder armour can be attached in either of two ways (see Fig. 3, a & b):

- The shoulder armour consists of both an armour panel (3,1) and a carrier unit (3,2). The armour plate is positioned behind the carrier and is attached to it by three nuts. This method of attachment allows fast replacement of the armour plating. The carrier is riveted to the fuselage.
- In the second design, the armoured carrier itself serves as the shoulder armour (see Fig. 3b).

The head armour is built into the canopy and is secured to it at its base, by two guide bars secured by hexagonal bolts, and, at its top, by a screwed on support strut. The strut is secured by two cables (see Part 1). In newer production aircraft, the head armour is secured by a sheet fairing and two cables; the support is then omitted.

- The bullet resistant windscreen is housed in a steel frame, and is secured to it by a screwed on molded framing.
- The side plates slide into the nose-over frame and are secured by a base rabbet.

## B. Nose armour

The oil cooler (4,2) and ring-shaped oil tank (4,4), both of matching circular construction, are enclosed by armoured rings which form the forward portion of the engine cowling. The cooler armour is secured by hexagonal screws; the oil tank armour by crown nuts. The five openings in the armoured nose ring, required for its installation, are covered by formed disks (4,9).

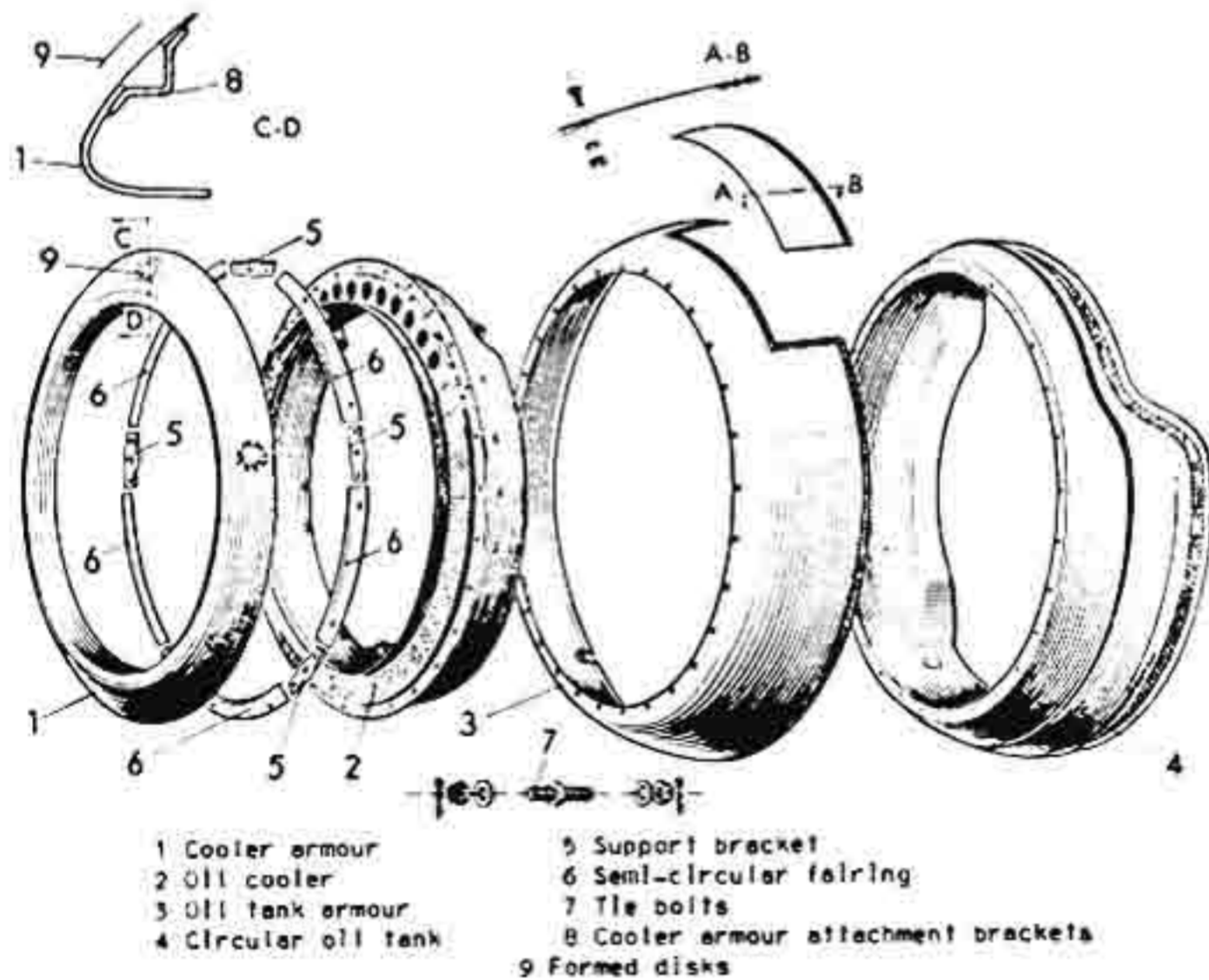

Fig. 4: Oil cooler and oil tank armour

A ten piece ring, consisting of five support brackets (4,5) joined to five semi-circular fairings (4,6), is positioned between the cooler armour and the cooler. The ring is secured to the oil cooler by crown nuts and tie bolts.

The air exit gap between the oil cooler and the oil tank armour is 10 mm.



D. (Luft) T. 2190 A-8

For Official Use Only!

# **Fw 190 A-8**

Aircraft Handbook

**Part 8E**

**Camera system**

**(Effective July 1944)**

**Issued September 1944**

## Description

### General

The 'Type 16 Gun camera' (BSK 16) is installed in the Fw 190A-8 fighter. Its installation in the field, in previously delivered aircraft, is made for A-8 series aircraft using Fw 190 Modification Instruction Nr. 85.

The 'Robot' miniature camera is installed in all ground-attack aircraft (Series F) and extended range fighter-bombers (Series G).

It is also possible, in fighter aircraft, to replace the BSK 16 with the 'Robot' using an adapter unit. In the 'Robot' installation, the lead from the camera to the weapons system is not attached.

### A. BSK 16 gun camera

The BSK 16 camera (1,1) is mounted on an adjustable platform (1,4) in the leading edge of the left wing panel between Ribs 3b (1,2) and 4 (1,3), and is attached to the aircraft electrical system by a plug connector (1,5). The camera lens opening in the wing leading edge is covered by a fairing and glass window (1,6); the clear glass panel can be exchanged for a coloured light filter.

The BSK 16 is a 16 mm movie camera. The film roll is 15 m (49.2 ft) in length, and is driven by an electric motor in the camera. The motor controls a switch which limits film movement to 3,75 m (12.3 ft) per run, and permits four film runs of from 43 to 57 seconds duration each. Depressing the firing button for the fuselage and wing-root weapons starts the camera.

The camera can also be triggered by depressing a button (1,9) on the throttle lever (1,10), thus

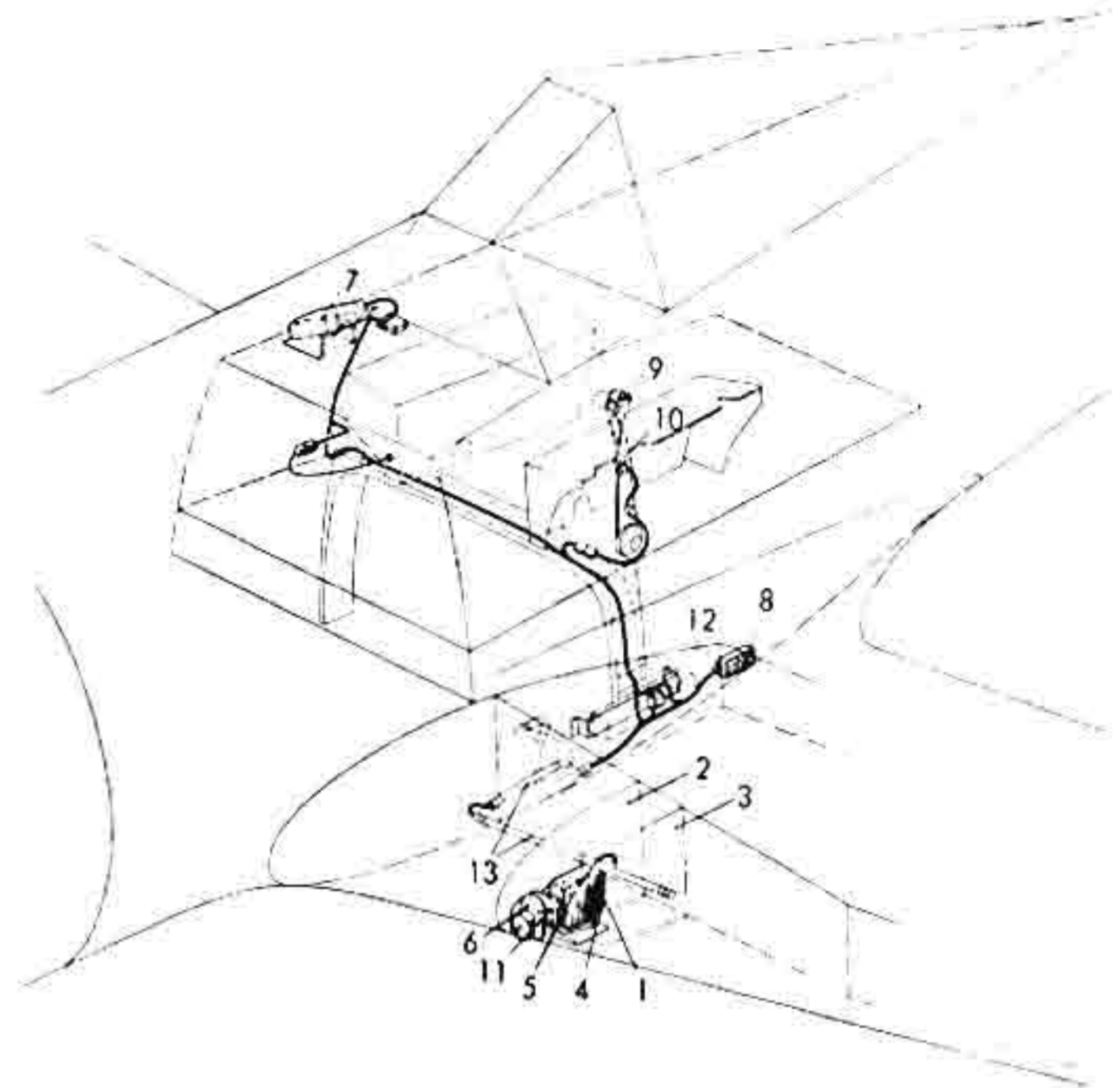

- |                        |                               |
|------------------------|-------------------------------|
| 1 BSK 16 camera        | 7 Electrical junction box     |
| 2 Rib 3b               | 8 Magnetic switch             |
| 3 Rib 4                | 9 Camera trigger              |
| 4 Camera platform      | 10 Throttle lever             |
| 5 Electrical connector | 11 Sighting image projector   |
| 6 Fairing with window  | 12 Circuitry separation point |
|                        | 13 Wire conduits              |

Fig. 1: BSK 16 (Ballistic gun camera) system

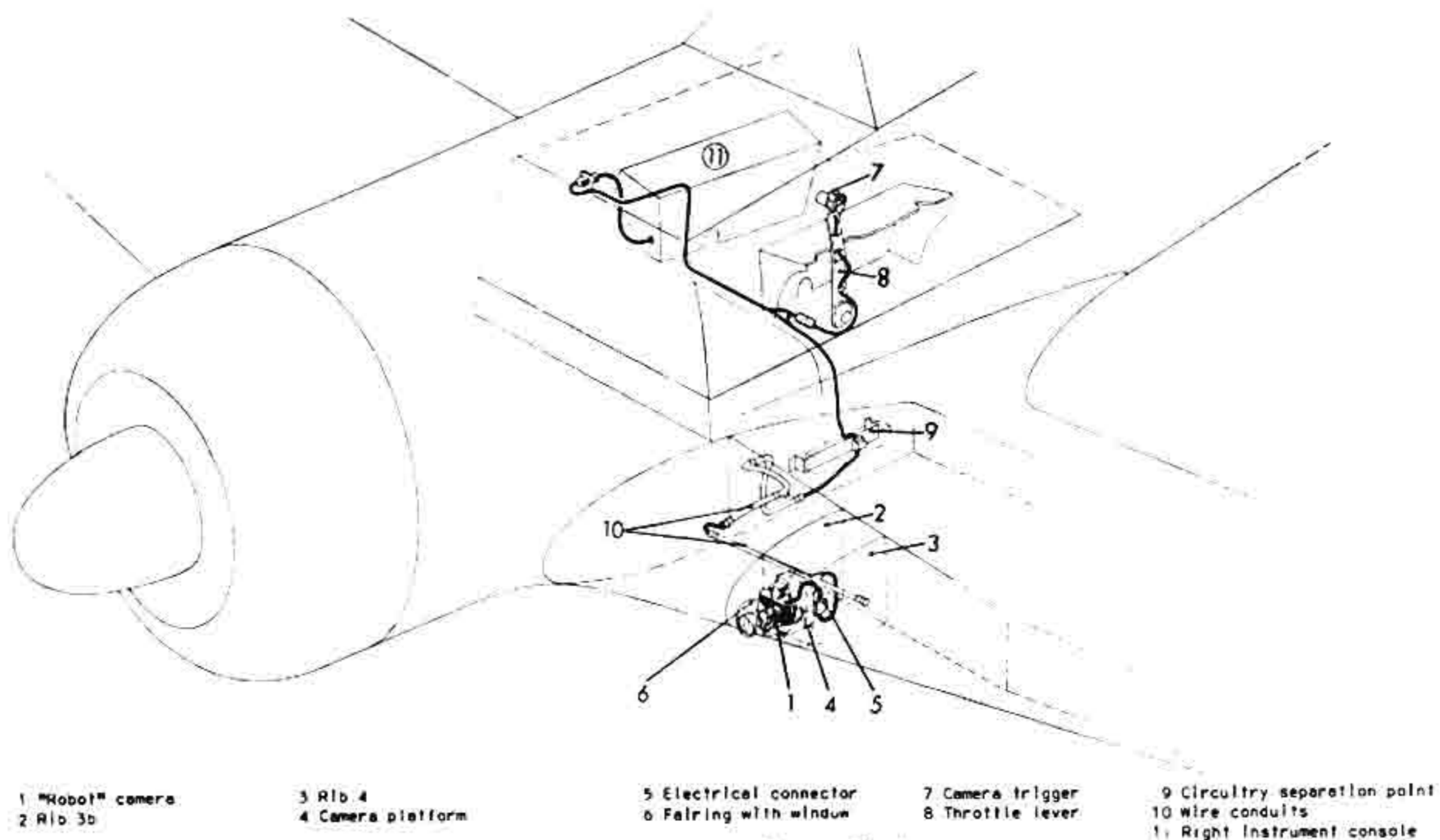

- |                  |                   |                        |                  |                              |
|------------------|-------------------|------------------------|------------------|------------------------------|
| 1 'Robot' camera | 3 Rib 4           | 5 Electrical connector | 7 Camera trigger | 9 Circuitry separation point |
| 2 Rib 3b         | 4 Camera platform | 6 Fairing with window  | 8 Throttle lever | 10 Wire conduits             |
|                  |                   |                        |                  | 11 Right instrument console  |

Fig. 2: 'Robot' camera installation



enabling gun camera photos to be taken without pressing the firing button.

## B. "Robot" miniature camera

With the 'Robot', Model II, miniature camera, single photos can be taken from high altitudes down to approximately 2000 m (6562 ft). The camera is aimed through the gunsight. Frame size is 2,4 x 2,4 cm, and the film roll is 1,6 m (5.25 ft) long.

The 'Robot' camera (2,1) is, as is the BSK 16, mounted on an adjustable platform (2,4) in the wing leading edge between Ribs 3b (2,2) and 4 (2,3), and

is attached to the electrical circuit by a plug connection.

The film is advanced by a spring device on the camera; this spring must be wound before each flight. Near the spring is situated an actuation button. When this button is pressed, the shutter is released and the film advanced one frame.

The circuitry for releasing the shutter is connected to a button (2,7) on the throttle lever (2,8). This button activates a magnet situated on the camera mount. The magnet triggers the charging lever which depresses the camera shutter release.

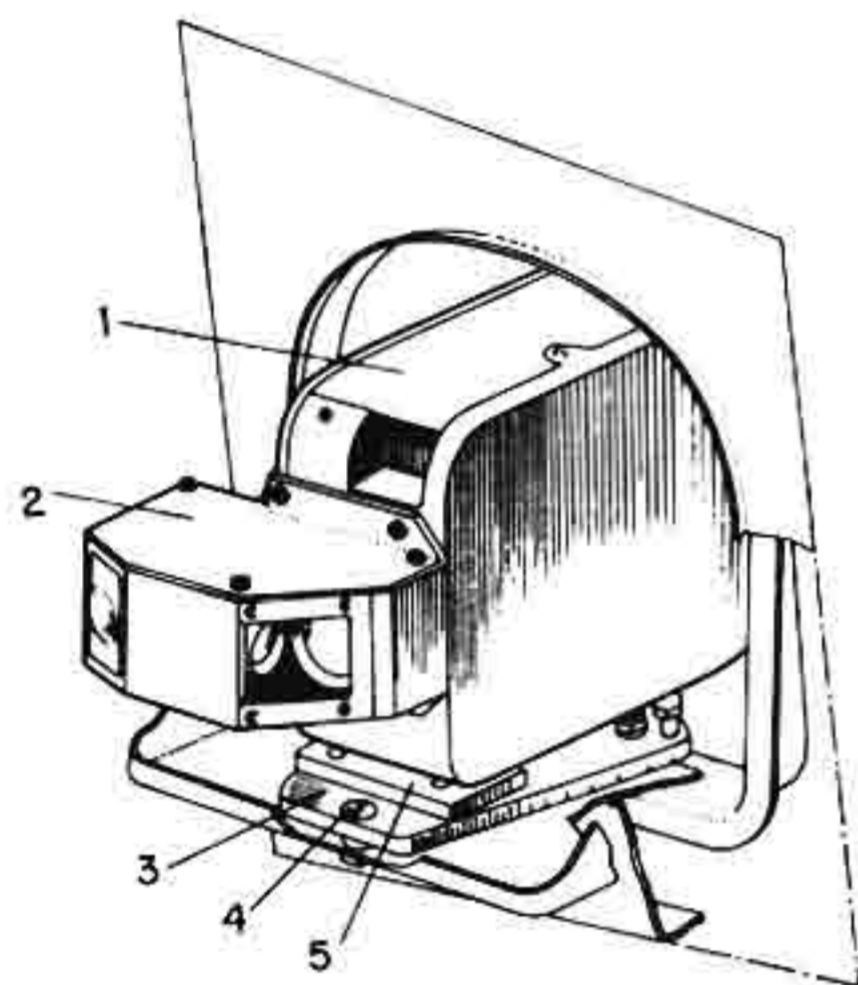

1 BSK 16 camera                      3 Adjustable platform  
2 Sighting image projector        4 Platform forward attachment point  
5 Camera forward fixing point

Fig. 3: BSK 16 camera

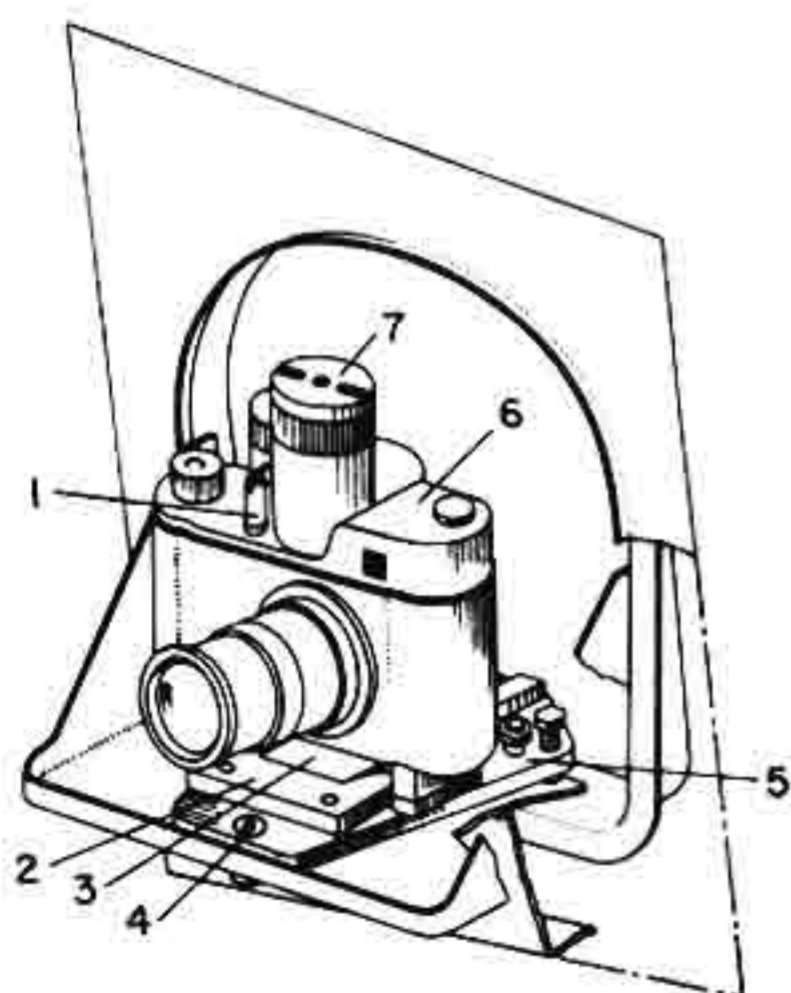

1 Shutter release                      4 Platform forward attachment point  
2 Camera forward fixing point      5 Adjustable platform  
3 Camera base plate                    6 "Robot" camera  
7 Film advance spring

Fig. 4: 'Robot' camera

D. (Luft) T. 2190 A-8

For Official Use Only!

# **Fw 190 A-8**

Aircraft Handbook

**Part 9A**

**General equipment**

**Supplement 1: PKS 12 Patin directional control**

**(Effective July 1944)**

**Issued September 1944**

## A. General

The PatIn directional control is used to maintain a required flight course by supplying automatic steering inputs to the rudder. This facilitates both flying in bad weather conditions and penetration of continuous cloud cover.

The sole control device provided for the pilot is the turn switch (V60) mounted on the control column. The switch comprises both a bipolar tumbler switch to engage and disengage the automatic pilot system, and a five position rate-of-turn switch which comprises a centre 'null' position and two turn rate positions each to right and left. These turn rate positions permit the initiation of a turn at either of two predetermined turning rates,  $1^\circ/\text{sec}$  or  $2^\circ/\text{sec}$ .

The elevator and ailerons are operated in the normal manner.

## B. Method of operation

Operation of the turn switch (V60) engages the course motor (K12) which is connected to the base of the repeater compass (V46) by a flexible cable, torque converter and spindle shaft. The course motor

is activated when the turn switch is operated, to turn the aircraft compass course onto a desired direction which is indicated by a reference stripe. After the pilot moves the turn switch to contact 1 or 2, the course motor will change the compass course at a turning rate of either  $1^\circ/\text{sec}$  or  $2^\circ/\text{sec}$ .

When the steering mechanism is disengaged, the rotation speed of the compass course indicator (through a weakening of the magnetic field within the course motor) is increased to  $6^\circ/\text{sec}$ . By manually turning the aircraft onto the desired heading before engaging the automatic pilot, the aircraft can be brought to the desired course in a shorter time.

Installed in the steering relay is a moving coil unit, with five electrically separated coils, which passes through the field of a permanent magnet. The various direction sensors create electrical currents of specific strengths and directions which act on given coils; the strength and direction of these currents are transmitted to the steering unit (K8).

In the steering unit (K8) are contained the steering

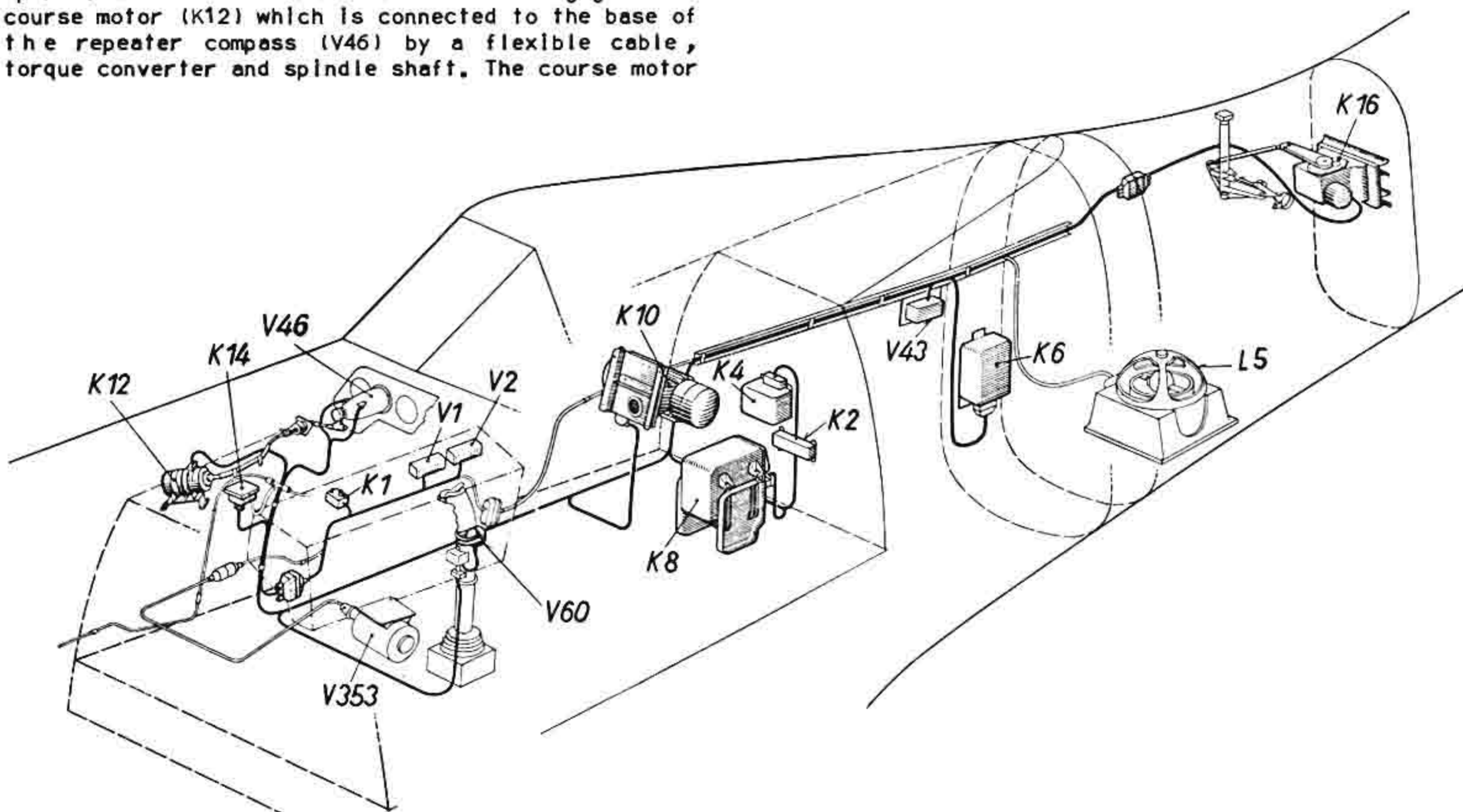

### Right Instrument console

- K 1 System circuit breaker
- V 1 Junction box
- V 2 Negative distributor

### Fuselage (Cockpit)

- K 12 Course motor
- K 14 Damping regulator
- K 46 Repeater compass (Main instrument panel)
- V 60 Turn switch (Control stick)
- V 353 Transformer

### Fuselage (Bulkhead 6-8)

- K 2 Junction box
- K 4 Impedance unit
- K 8 Steering unit
- K 10 Leonard transformer

### Fuselage (Bulkhead 9-12)

- K 6 Position integration unit
- L 5 Master compass
- V 43 Negative distributor

### Tail

- K 16 Rudder drive

and mixing units for the systems:

- 1) The damping circuit;
- 2) The steering relay; and,
- 3) The oscillating transformer.

The damping circuit is fitted with a matching circuit in which the voltage generated by a divergence from horizontal flight is matched by an equal and opposite voltage generated by the circuit.

The oscillating transformer has an AC frequency of 50Hz--input to one of the coils in both the position integration unit and the steering unit, so that slight vibrations will not, through slippage or jamming, cause seizure.

The damping regulator (K14) includes an air intake pipe in which the movement of the shaft operates an electrical transmission line which relates the deflection of the rudder to the aircraft speed. Thus at greater speeds the required rudder deflection is less than at lower speeds.

As only an average course is maintained by the steering unit, small deviations from the required course cause only very weak currents which will not result in operation of the steering unit.

The Leonard transformer (K10) is an DC-DC transformer, and is excited by the steering control current produced by the steering relay. The current is then passed to the armature of the DC motor in the rudder drive (K16).

The rudder drive also contains an electrical coupling, operated from the automatic pilot engaging switch (V60), which connects the gear drive to the rudder actuating lever. When the rudder drive is disengaged, however, the rudder is released.

Within the impedance casing (K4) is located an adjustable resistor to control the adjustment rate of the actuating spindle on the course motor (K12). Additionally, two relays are provided, which when the automatic pilot is uncoupled (disengaged), cause a weakening in the field of the course motor (K12), thus permitting a higher adjustment rate of the actuating spindle and thereby the compass course indicator.



D.(Luft) T. 2190 A-8

For Official Use Only!

# **Fw 190 A-8**

Aircraft Handbook

**Part 9A**

**General equipment**

**(Effective July 1944)**

**Issued September 1944**

# I. Instrument panels and consoles

## I. Instrument panels

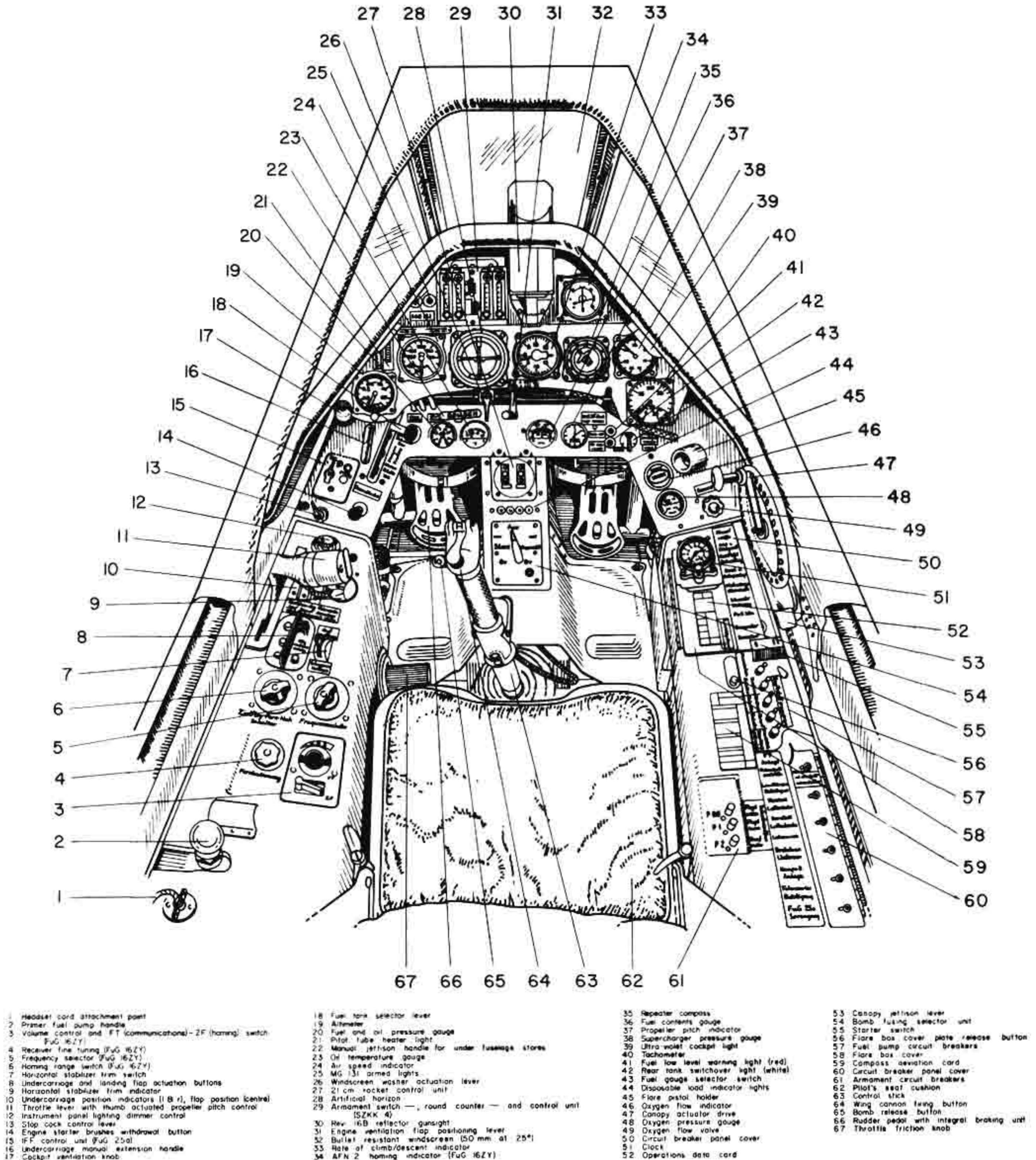

Fig. 1: Cockpit interior

The instrument panels comprise a main panel (Fig. 2) and an auxiliary panel (Fig. 3). In the area above these panels are positioned additional instruments and the instrument glare cover. A third instrument panel, situated between the auxiliary panel and the floor, serves as the armament panel.

The auxiliary instrument panel base plate is a load bearing component of the fuselage and is secured to it (Instrument bulkhead).

circuit breakers, the engine starter switch, the flare gun ammunition and the aircraft clock. The electrical system circuit breakers are protected by spring-loaded covers and designated by name plates near the covers.

In more recently produced aircraft the two groups of circuit breakers are consolidated into one.

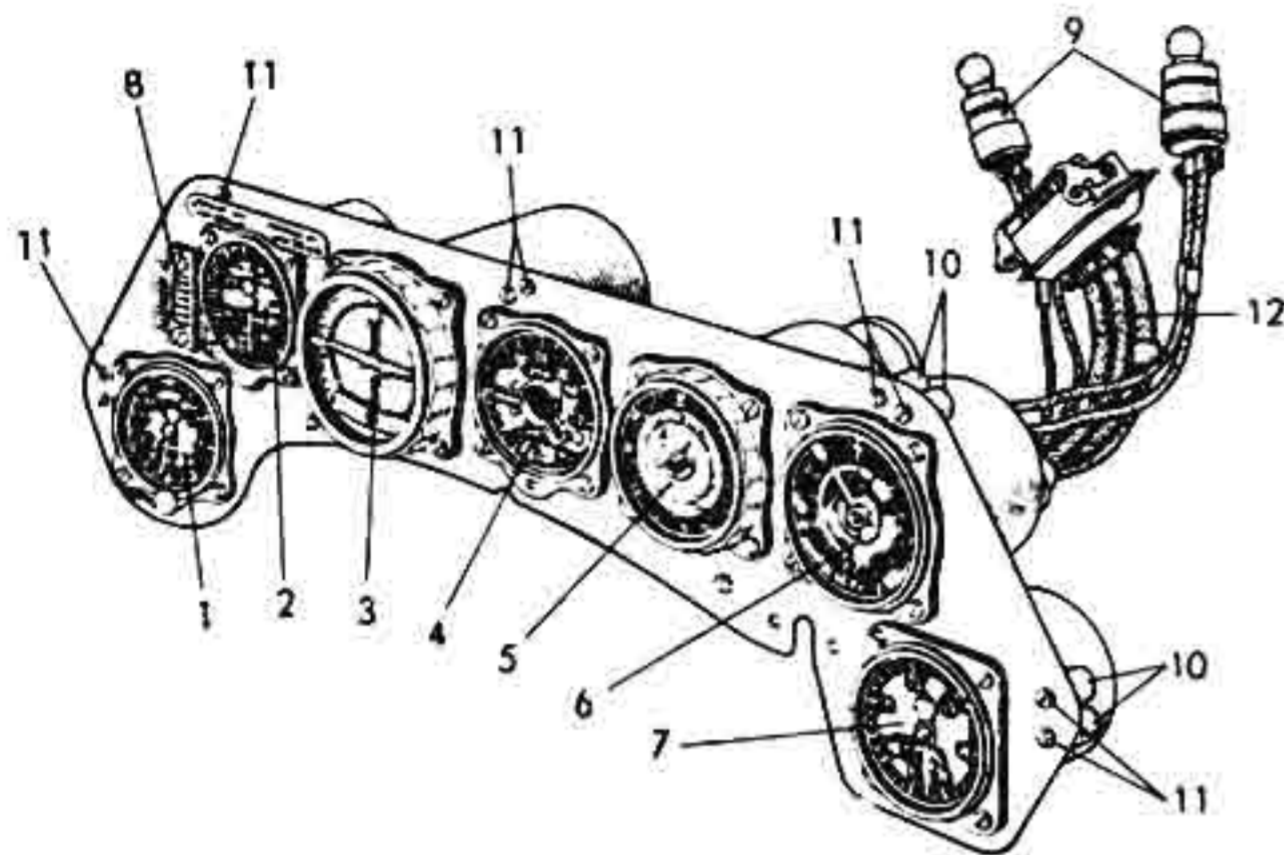

- |                               |                           |
|-------------------------------|---------------------------|
| 1 Pressure altimeter          | 7 Tachometer              |
| 2 Airspeed indicator          | 8 Pilot tube heater light |
| 3 Artificial horizon          | 9 Light sockets           |
| 4 Vertical speed indicator    | 10 Rubber shock mounts    |
| 5 Repeater compass            | 11 Mounting points        |
| 6 Supercharger pressure gauge | 12 Electrical leads       |

Fig. 2: Main instrument panel

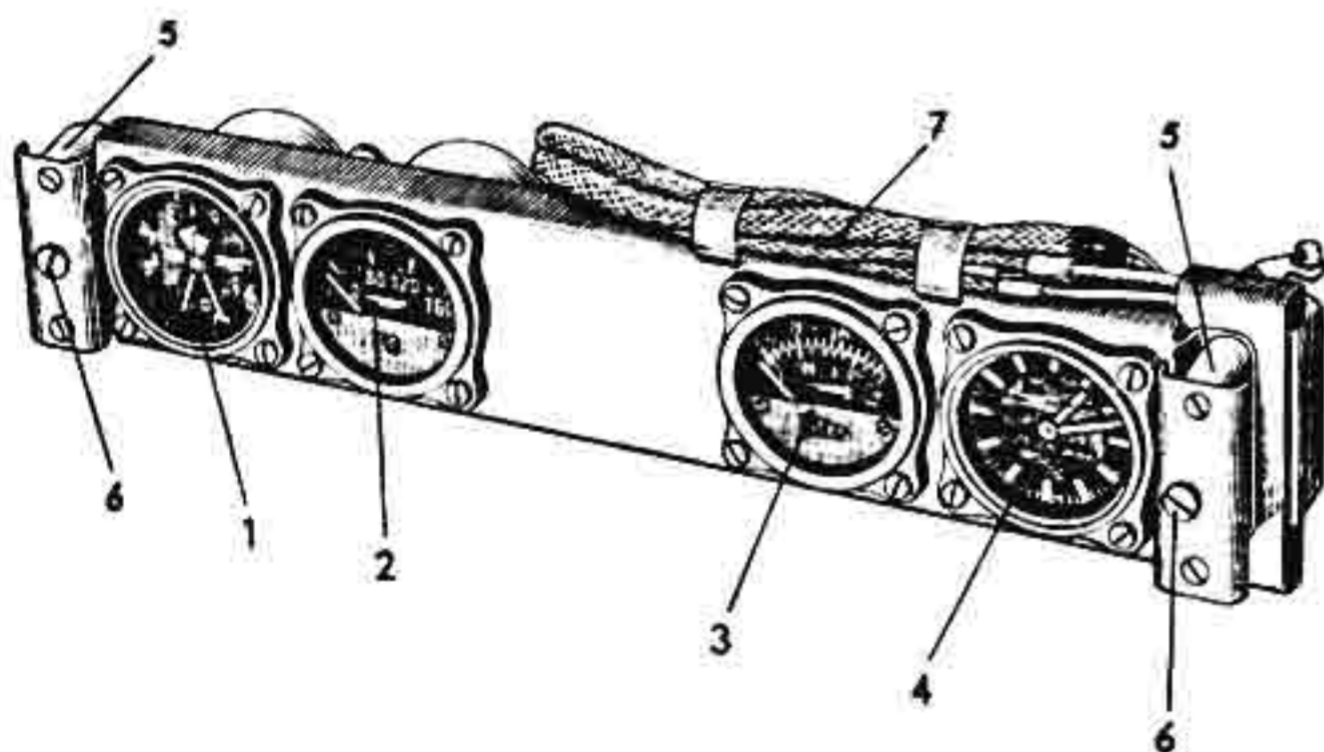

- |                               |                                |
|-------------------------------|--------------------------------|
| 1 Fuel and oil pressure gauge | 4 Propeller pitch indicator    |
| 2 Oil temperature gauge       | 5 Rubber shock mounts          |
| 3 Fuel contents gauge         | 6 Base plate attachment points |
| 7 Electrical leads            |                                |

Fig. 3: Auxiliary instrument panel

## 2. Instrument consoles

The left and right instrument consoles contain operating controls and circuit breakers. The left console contains the engine primer pump and the battery master switch, as well as the controls and monitoring instruments for the undercarriage, the landing flaps and the stabilizer incidence; the right console, all aircraft electrical system

## II. Powerplant monitoring instruments

### 1. Supercharger pressure gauge

The supercharger pressure gauge (1,38) is mounted on the right side of the main instrument panel. Instrument range: 0,6-1,8 ata (8,5-25,5 psi).

For the routing of the instrument measuring line see Fig. 4.

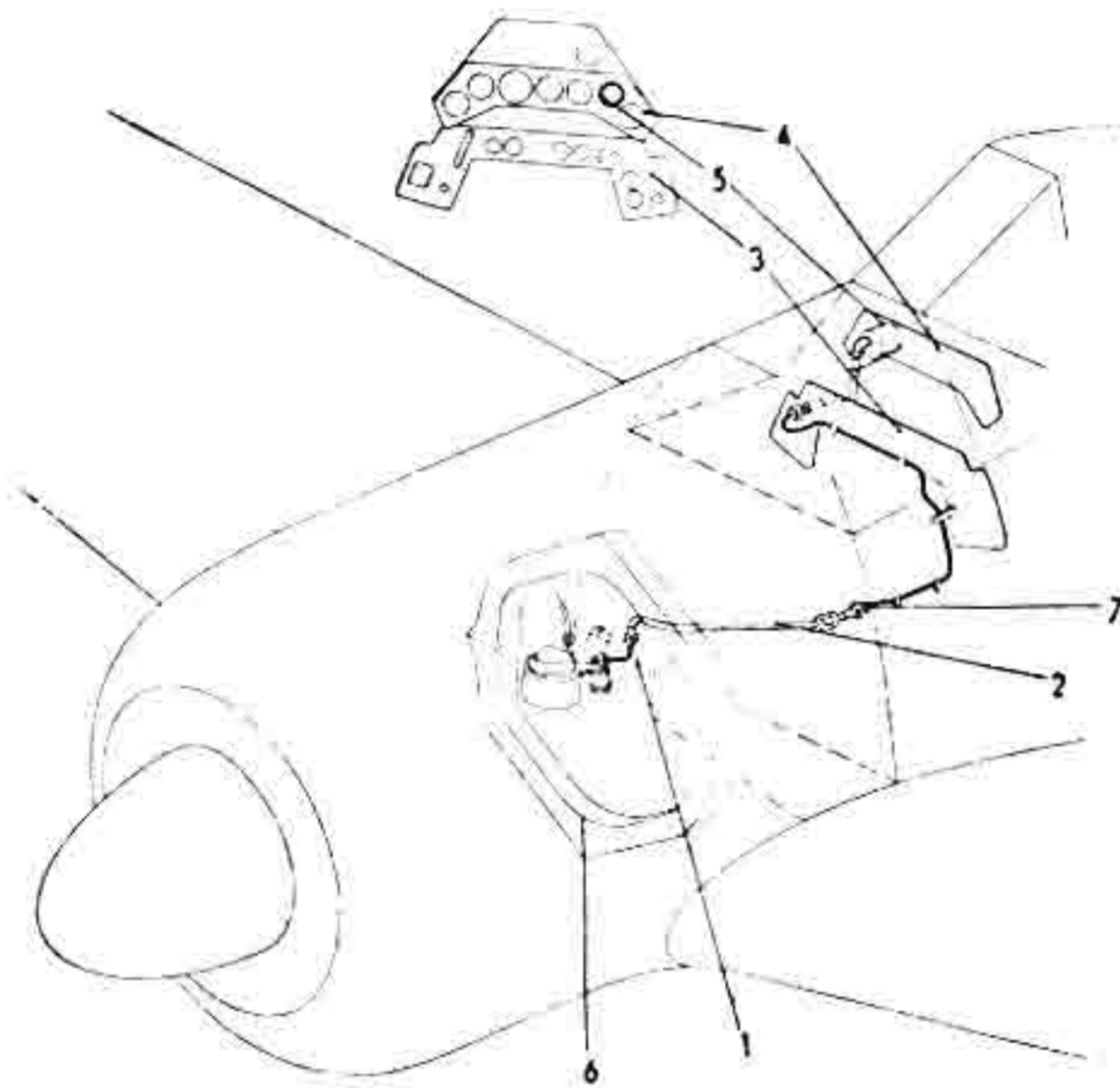

- 1 Attachment point of the supercharger pressure line to the command unit
- 2 Supercharger pressure measuring line
- 3 Auxiliary instrument panel
- 4 Main instrument panel
- 5 Supercharger pressure gauge
- 6 Engine mounting ring
- 7 Separation point 2 on Bulkhead 1 (Firewall)

Fig. 4: Supercharger indicator system

### 2. RPM gauge

The RPM gauge (1,40) is positioned on the right side of the main instrument panel. The engine and the gauge are connected by a flexible cable.

Measurement range: 600-3600 rpm.

An oil extractor (5,3) is built into the flexible cable near its point of attachment to the engine. Any oil that has penetrated the cable is extracted at this point and allowed to drop into the engine compartment.

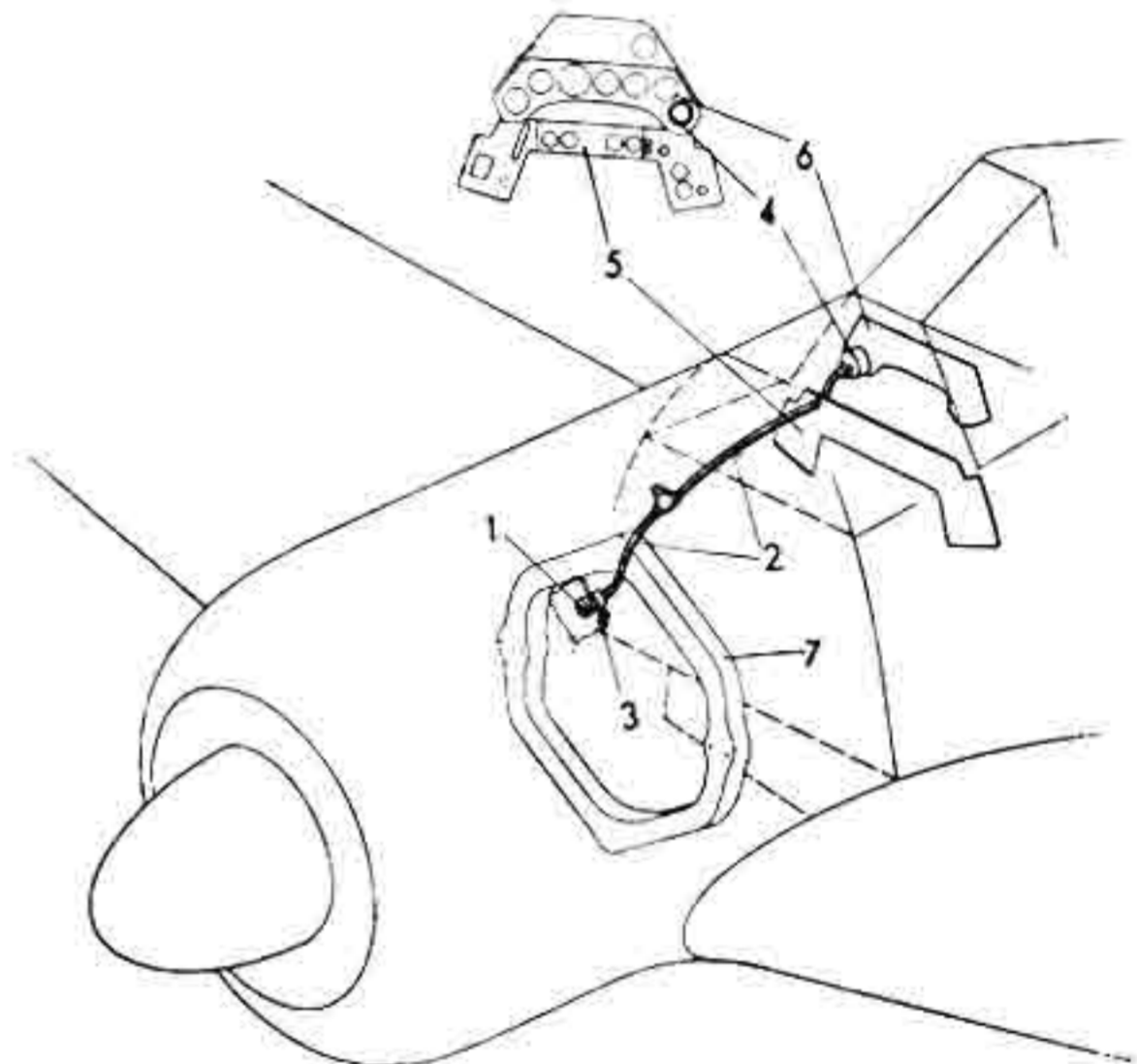

- 1 Attachment point of the measurement cable to the engine
- 2 Flexible cable
- 3 Oil extractor
- 4 RPM gauge
- 5 Auxiliary instrument panel
- 6 Main instrument panel
- 7 Engine mounting ring

Fig. 5: Engine RPM measurement system



### 3. Fuel and oil pressure gauge

The dual pressure gauge (1,20) is mounted on the near left side of the auxiliary instrument panel. The feed pressure of the pumps is indicated in Kg/sq cm.

Fuel pressure range 0- 3,0 Kg/sq cm (0- 42,6 psi)  
Oil pressure range 0-15,0 Kg/sq cm (0-213,0 psi)

The operating limits are marked by indicator lines.

### 4. Oil temperature gauge

This instrument (1,23) is positioned in the near left side of the auxiliary instrument panel, and provides an indication of oil temperature. The unit consists of an electrical probe (7,1) and an indicator (7,2), and uses the 24 volt aircraft electrical system. Indication range: 0-130°C (32-266°F).

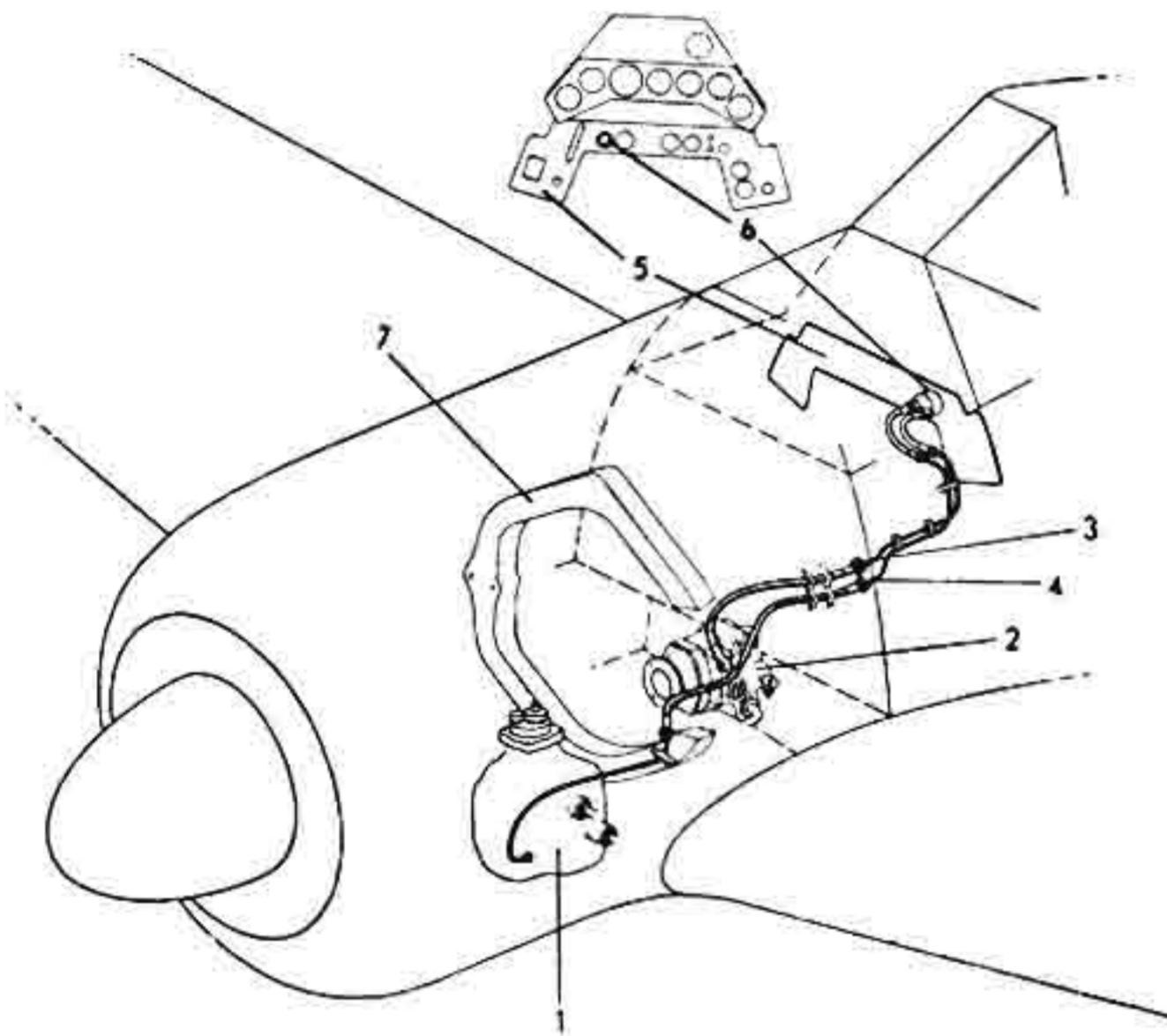

- 1 Oil pump
- 2 Fuel pump
- 3 Fuel pressure line separation point
- 4 Oil pressure line separation point
- 5 Auxiliary instrument panel
- 6 Fuel and oil pressure gauge
- 7 Engine mounting ring

Fig. 6: Fuel and oil pressure measurement system

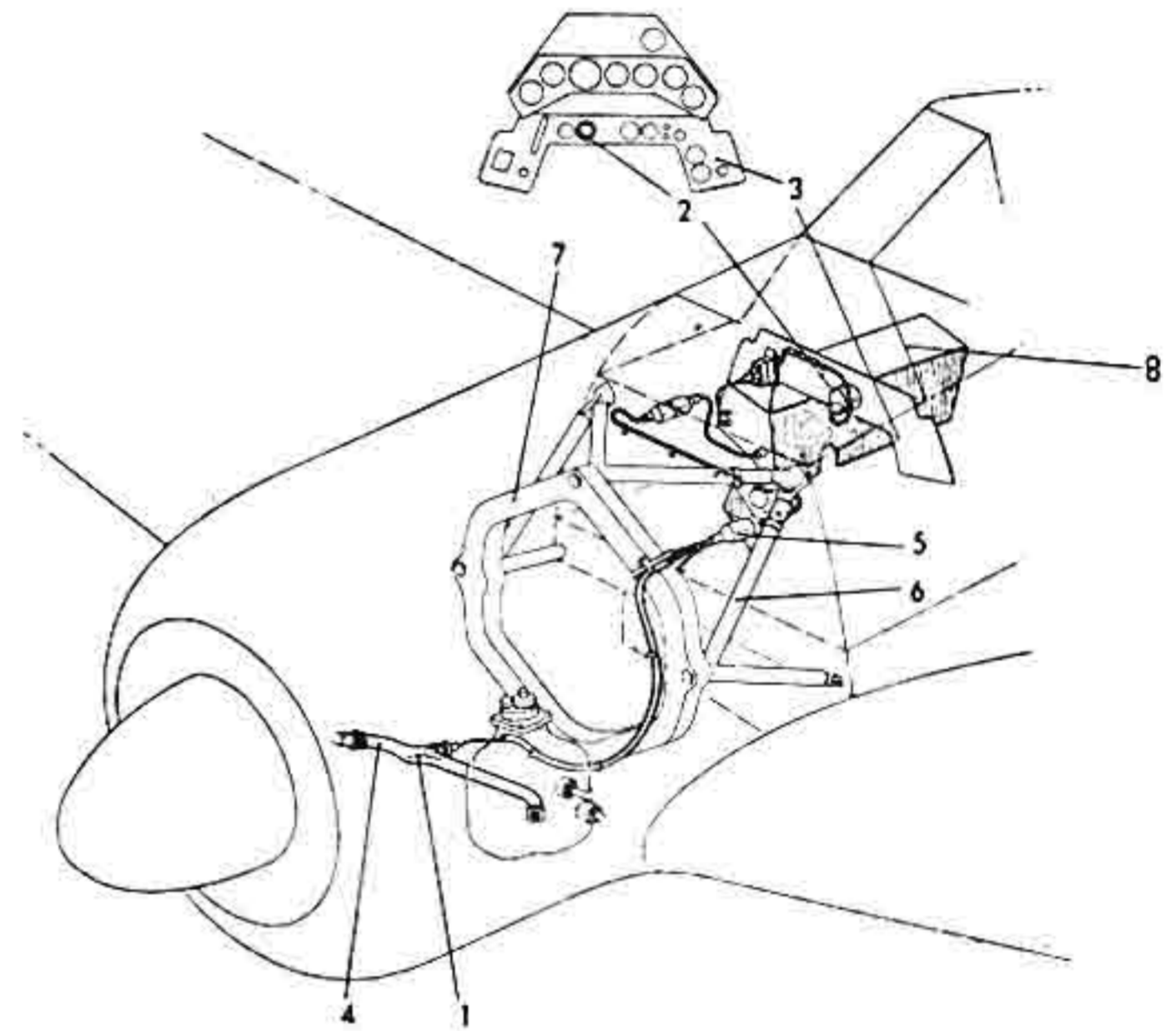

- 1 Electrical temperature probe
- 2 Oil temperature gauge
- 3 Auxiliary instrument panel
- 4 Oil line from cooler to main pump
- 5 Separation point 10
- 6 Engine bearer assembly
- 7 Engine mounting ring
- 8 Right instrument console

Fig. 7: Oil temperature measuring circuit

## 5. Fuel contents gauge

The electrical fuel contents gauge, (1,36) and (8,1), is positioned on the rear right side of the auxiliary instrument panel (8,2); it is possible to individually measure, in liters, the contents of each main fuel tank.

The unit consists of a fuel contents probe with low level warning attachments in both the rear (8,3) and forward (8,4) tanks, and an indicator unit (8,1). Indicator lights (8,5) are positioned in the Instrument bulkhead. The lower, white light, acting as tank switchover warning, illuminates when rear tank contents have dropped to 10 Ltr (2,2 gal); the upper, red light, provides return to base warning, illuminating when 80 Ltr (17,6 gal) remain in the forward fuel tank. Plate inscription: 20 minutes remaining at economical cruise.

A gauge selector switch (8,6) enables the indicator unit to be switched to measure the contents of the forward or rear tank.

Operating power: 24 volts.

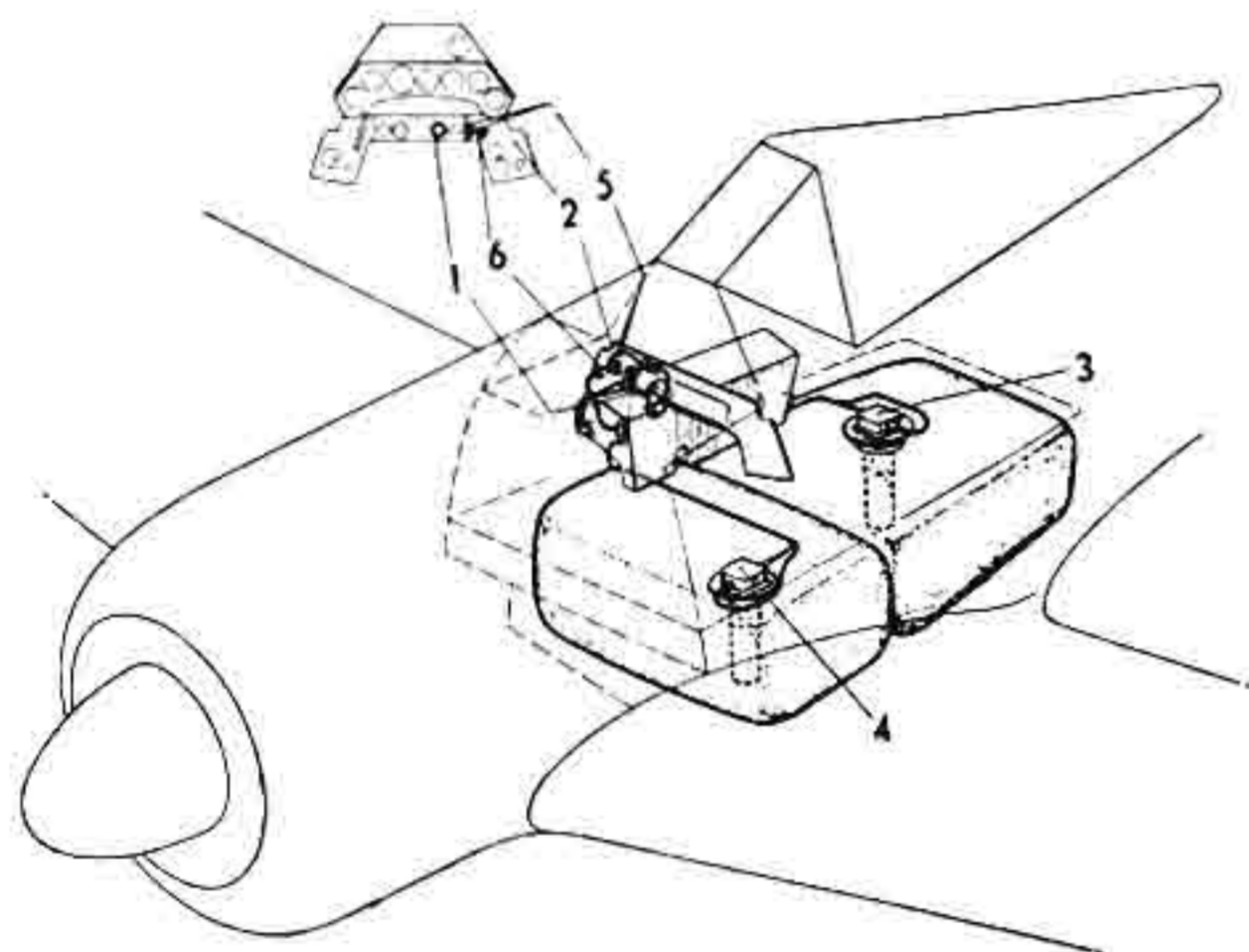

- 1 Fuel contents gauge
- 2 Auxiliary instrument panel
- 3 Rear tank contents probe with low level warning
- 4 Forward tank contents probe with low level warning
- 5 Indicator lights (low level warning)
- 6 Fuel gauge selector switch

Fig. 8: Fuel tank contents circuit

## 6. Mechanical airscrew pitch indicator

The unit, (1,37) and (9,1), serves to indicate the pitch of the adjustable airscrew. Indication impulses are fed from the pitch control unit (9,2) via a flexible cable (9,3). The propeller blade pitch indication is given in hours and minutes.

For operation and maintenance of the unit consult the appropriate publications.

From time to time examine the cable attachment points for good seating, to prevent line damage due to chafing.

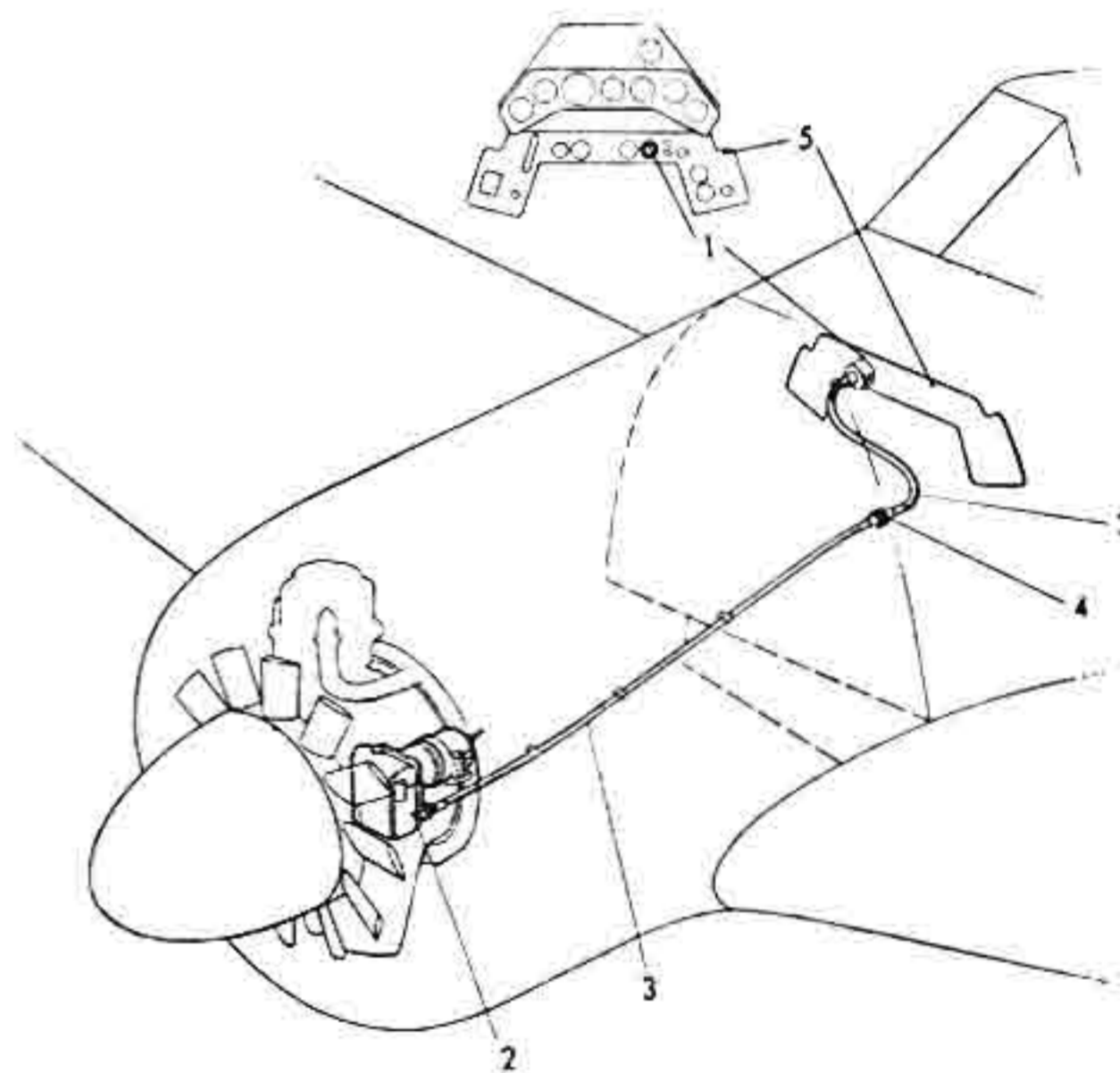

- 1 Pitch Indicator
- 2 Hydraulic-electric pitch control unit
- 3 Flexible cable
- 4 Separation point 1 on Bulkhead 1
- 5 Auxiliary instrument panel

Fig. 9: Airscrew pitch indicator

## III. Flight monitor and navigation instruments

### 1. Pressure altimeter

The unit, (1,19) and (10,1), is positioned on the left side of the main instrument panel (10,2).

Measuring range: 0-10 km (0-32810 ft).

Measurement limits: 'descent' and 'climb'

3000-0-3000 m/s (9840-0- 9840 fps)

2000-0-5000 m/s (6560-0-16400 fps)

The bottom figure is the maximum value of the older indicators.

### 4. Artificial horizon

Location of the unit (1,28): centre main instrument panel. It indicates the position of the aircraft relative to the natural horizon, and the turn speed and speed of rotation of the aircraft about its vertical axis.

For detailed instructions concerning the inspection, installation, operation, servicing, and maintenance of the unit see D.(Luft)T.5405.

### 5. Remote compass system

The system comprises the master compass and the pilot's repeater compass. The master compass (11,1) is located in the rear fuselage; the repeater compass (11,2), in the rear right side of the main instrument panel.

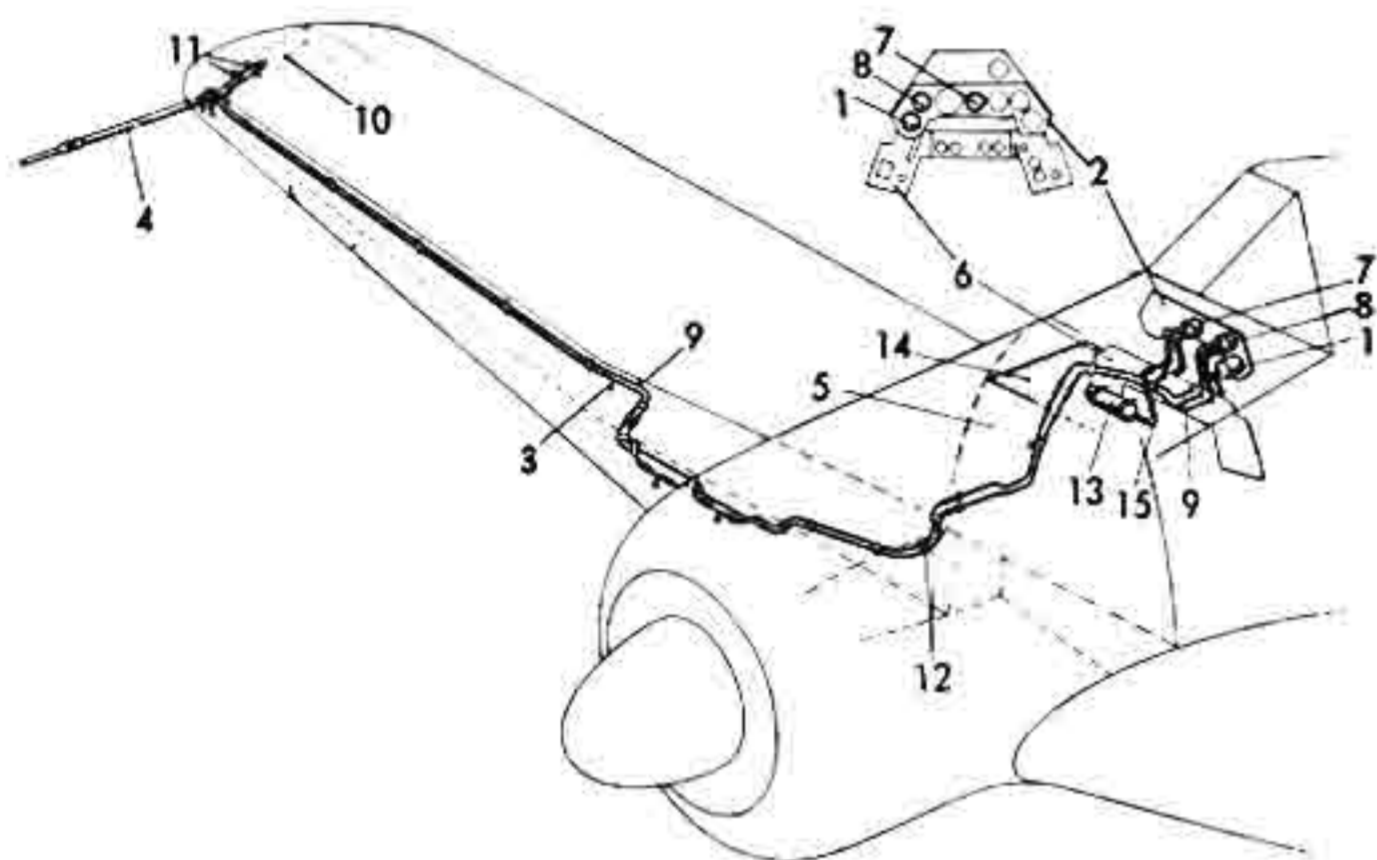

- |                              |                                   |
|------------------------------|-----------------------------------|
| 1 Pressure altimeter         | 8 Airspeed Indicator              |
| 2 Main instrument panel      | 9 Dynamic air pressure line       |
| 3 Static pressure line       | 10 Rib 15R                        |
| 4 Pitot tube                 | 11 Pitot tube heater line         |
| 5 Bulkhead 1                 | 12 Wing-root separation point     |
| 6 Auxiliary instrument panel | 13 Differential pressure chamber  |
| 7 Vertical speed indicator   | 14 Decking in front of windscreen |
|                              | 15 Air line                       |

Fig. 10: Flight monitor instrument circuits

### 2. Airspeed indicator

The airspeed indicator, (1,24) and (10,8), is positioned on the left side of the main instrument panel (10,2).

It is connected to both the static air pressure line (10,3) and to the dynamic air pressure line (10,9); the two lines are routed parallel to one another.

When the pitot tube heater is switched on, a latticed indicator located on the left side of the main instrument panel is illuminated.

### 3. Vertical speed indicator

The indicator, (1,33) and (10,7), is positioned in the centre of the main instrument panel (10,2) and is connected to the static air pressure line (10,3). The differential pressure tank (10,13) is secured by two clamps beneath the decking in front of the windscreen (10,14), and is connected to the vertical speed indicator by an air line.

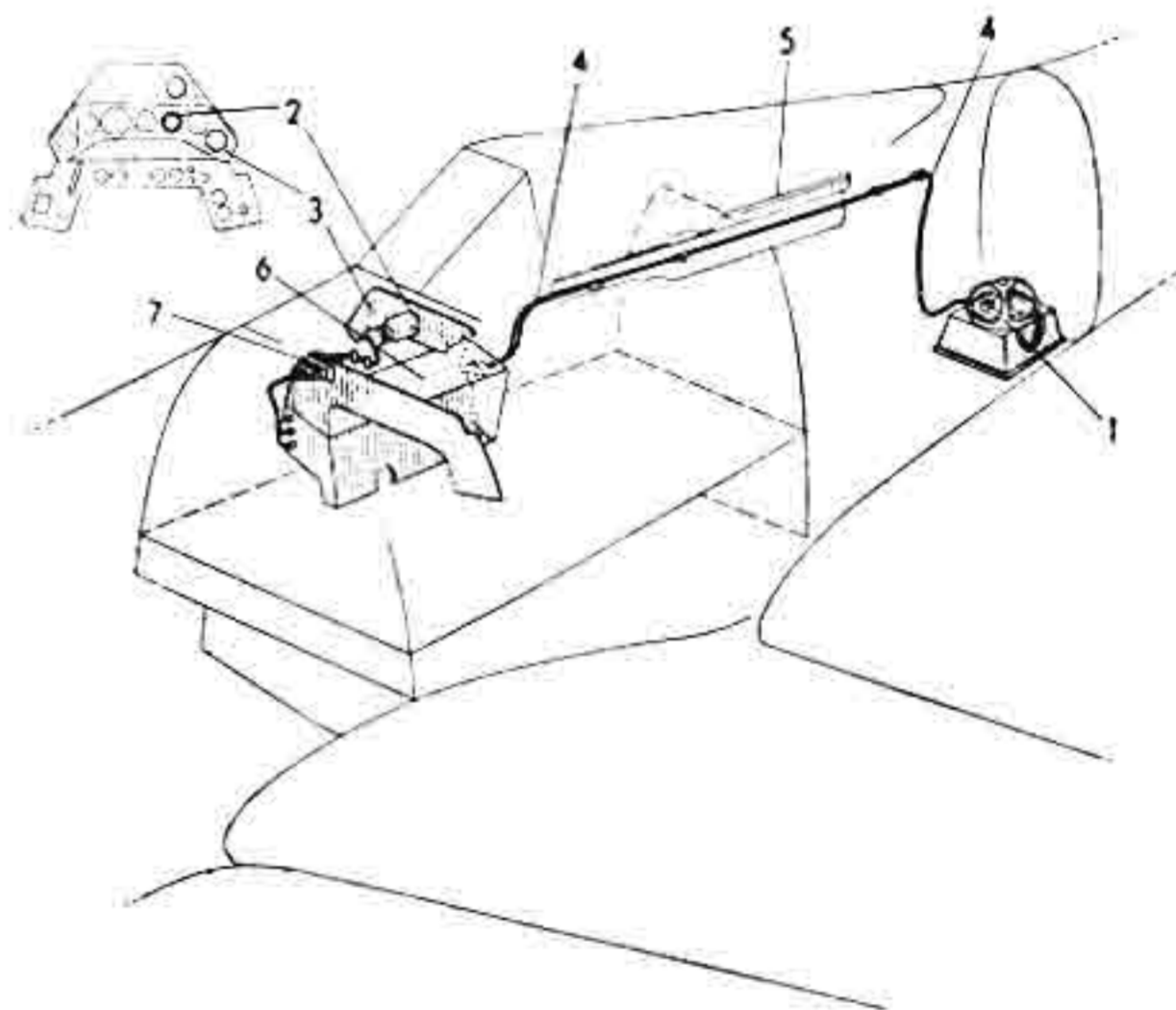

- |  |
|--|
| 1 Master compass                         |
| 2 Pilot's repeater compass               |
| 3 Main instrument panel                  |
| 4 Signal transmission unit               |
| 5 Cable shield between Bulkheads 6 and 8 |
| 6 Right instrument console               |
| 7 Plug connector                         |

Fig. 11: Remote compass system

## 6. Stabilizer incidence indicator

This system consists of the stabilizer incidence relay unit (12,1) and indicator (12,2). The indicator (13,7) and the actuation switch (13,8) are located in the left instrument console.

The incidence relay unit (13,1) is positioned in the right side of the vertical stabilizer and is connected to the triangular stress frame (13,5) by a push rod (13,4). The stabilizer incidence is indicated as + or - (Fig. 14).

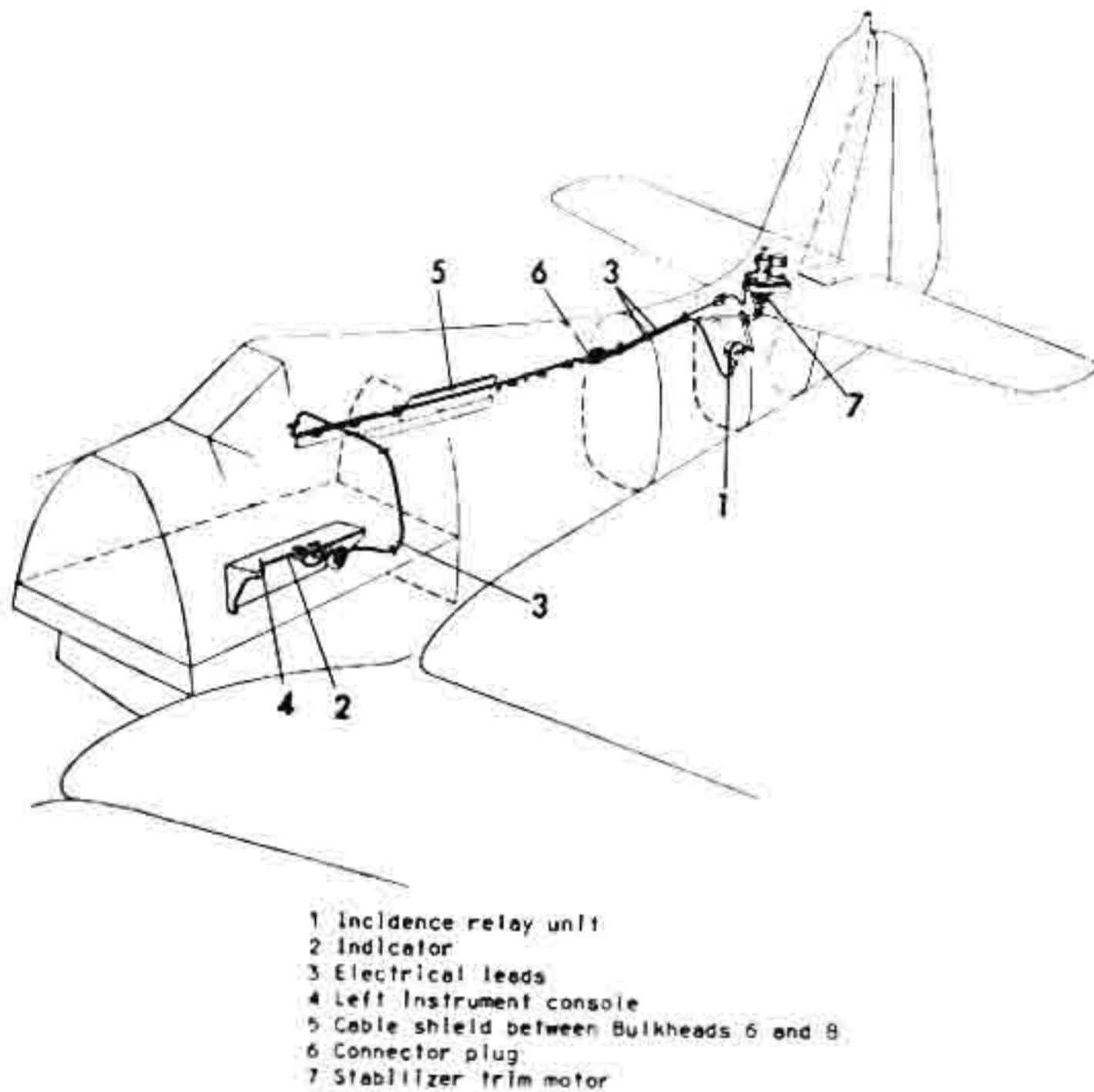

Fig. 12: Stabilizer trim system

### Trim system Indication

The stabilizer null setting and limit settings are marked on the stabilizer fairing and left cover plate (Fig. 14), and on the indicator (Fig. 15).

The stabilizer null setting is marked on the stabilizer fairing (14,2), in the centre of the overlap, by a red stripe which is extended for 50 mm onto the cover plate. It is annotated "Anzeigegerät 0" in red letters 10 mm high.

At the stabilizer maximum negative setting, a stripe, 25 mm long, is marked on the cover plate, and denoted by a - (minus). A similar stripe is marked at the stabilizer maximum positive setting. It is indicated by a + (plus).

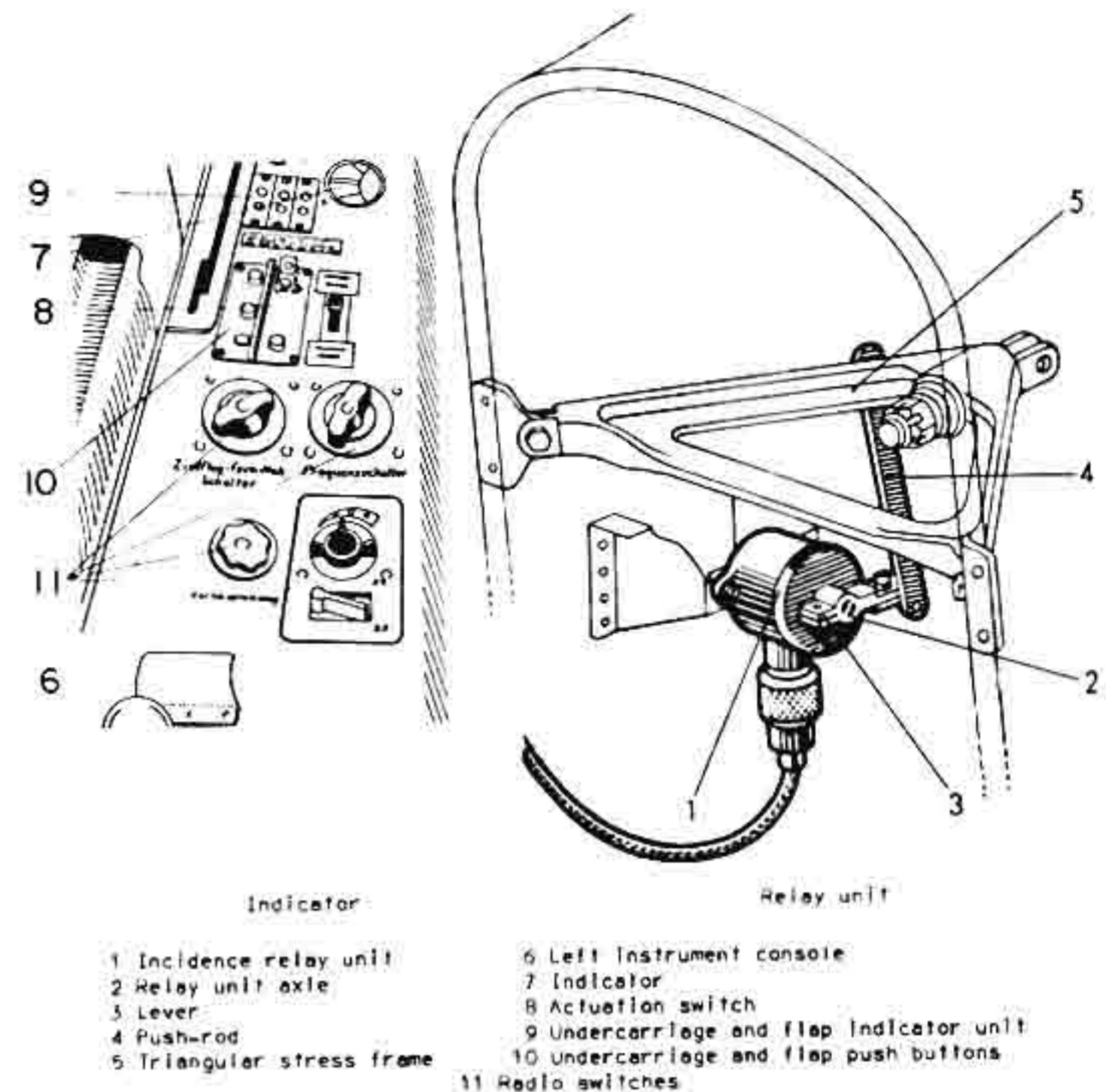

Fig. 13: Stabilizer trim system

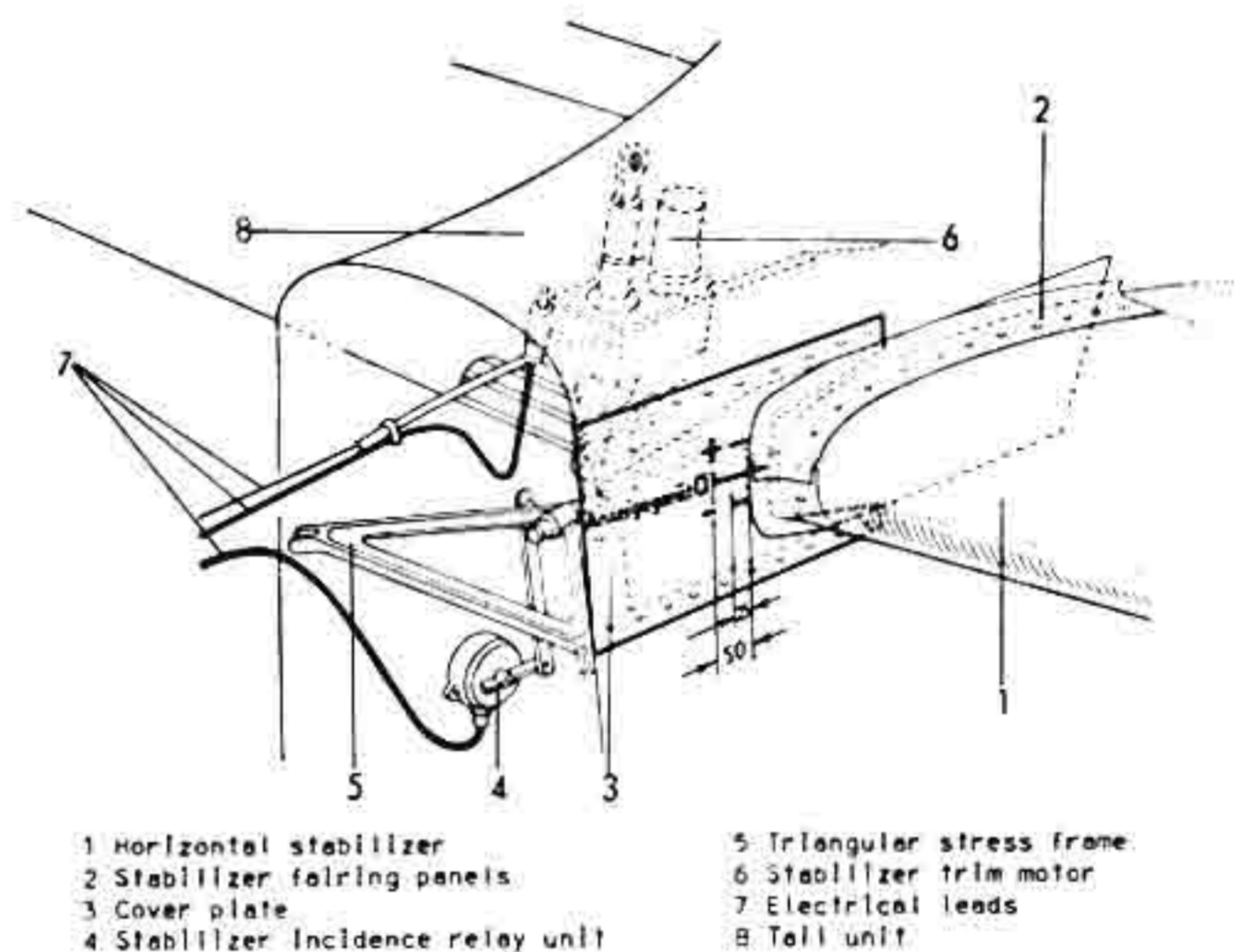
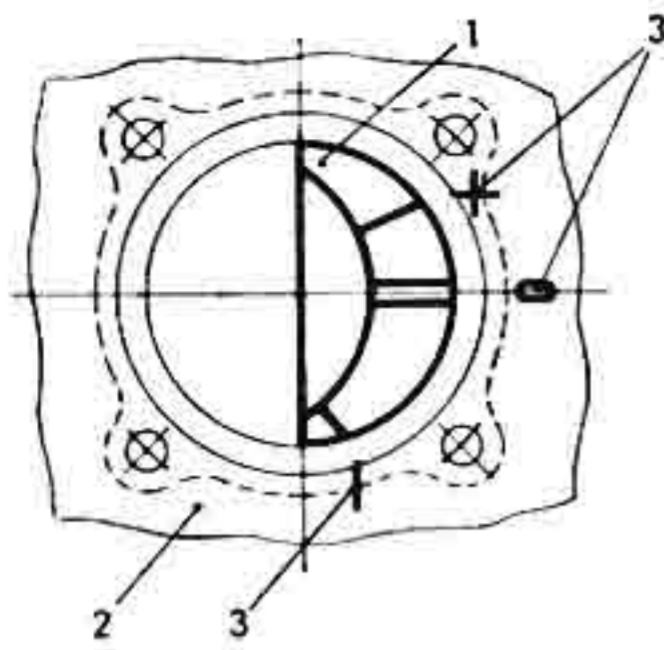

Fig. 14: Tail unit trim components

These registration marks are placed on the fuselage left side only.

During inspection of the stabilizer trim system ensure that the registration marks on the indicator and on the cover plate are in agreement.



- 1 Stabilizer incidence indicator
- 2 Left instrument console
- 3 Stabilizer incidence notations

Fig. 15: Indicator

**7. Aircraft clock**

Position: on the right instrument console (1,51).

**IV. Oxygen system**

**A. Description**

The system consists of three two liter light steel spherical bottles (16,8), a regulator unit (16,1) with oxygen hose (16,2), high pressure lines (16,3) with pressure gauge (16,5), an oxygen flow monitor (16,4), and a flow valve (16,6).

The oxygen bottles are mounted at the base of the radio compartment (equipment bay) behind Bulkhead 9; two are on the fuselage right side--facing the equipment bay access door--and the third is on the left side beneath the equipment bay door. As a safety measure, the three bottles are divided into two separate systems by the installation of four non-return valves. A non-return valve is built into the filler line, between the external connection and the first oxygen bottle. The regulator unit is positioned behind the pilot's seat on the right side frame; the pressure gauge, oxygen flow monitor and flow valve are on the auxiliary instrument panel right side.

After the flow valve is opened, the oxygen first flows to the regulator unit. The emergency pressure button on the regulator can be actuated by the right elbow of the pilot.

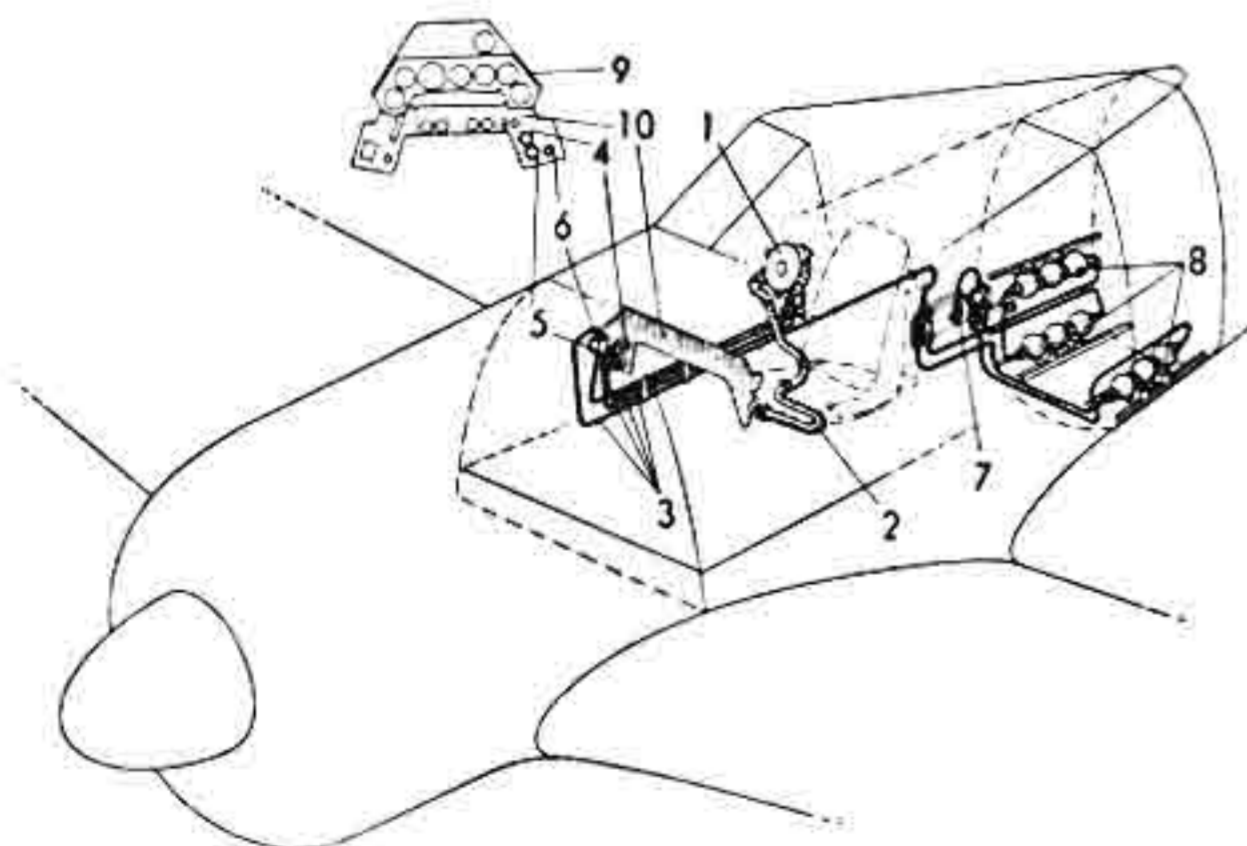

- 1 Regulator unit
- 2 Hose
- 3 High pressure lines
- 4 Flow monitor
- 5 Pressure gauge
- 6 Flow valve
- 7 External filler point
- 8 Oxygen bottles
- 9 Main instrument panel
- 10 Auxiliary instrument panel

Fig. 16: Aircraft oxygen system

**B. Inspection**

Inspect the oxygen system for proper operation, satisfactory condition and secure mounting. See D.(Luft) 1205.

**Short test**

Open the valve, read the pressure, close the valve. In 20 minutes, the system pressure (150 atü) must not fall by more than 10 atü.

## V. Rescue and safety equipment

### 1. First aid kit

The first aid kit is positioned within the right side of the rear fuselage between Bulkheads 9 and 10, and is accessible from the outside.

### 2. Flare gun

The flare gun is located in the right side of the Instrument bulkhead (1,45). There it is inserted in

a tube and can, from that position, be fired. The required ammunition is carried within the right instrument console (1,58).

### 3. Seat straps and parachute

The pilot's seat is outfitted with lap and shoulder straps, with integral quick-release mechanism. The pilot is provided with a back parachute and a one-man dinghy pack.

## VI. Windscreen cleaning

The spray tubes (17,9 & 10) are so positioned that when the stop cock is opened, fuel expelled through the small holes in the tubes, will be blown rearward by the slipstream to clean the three glass panels.

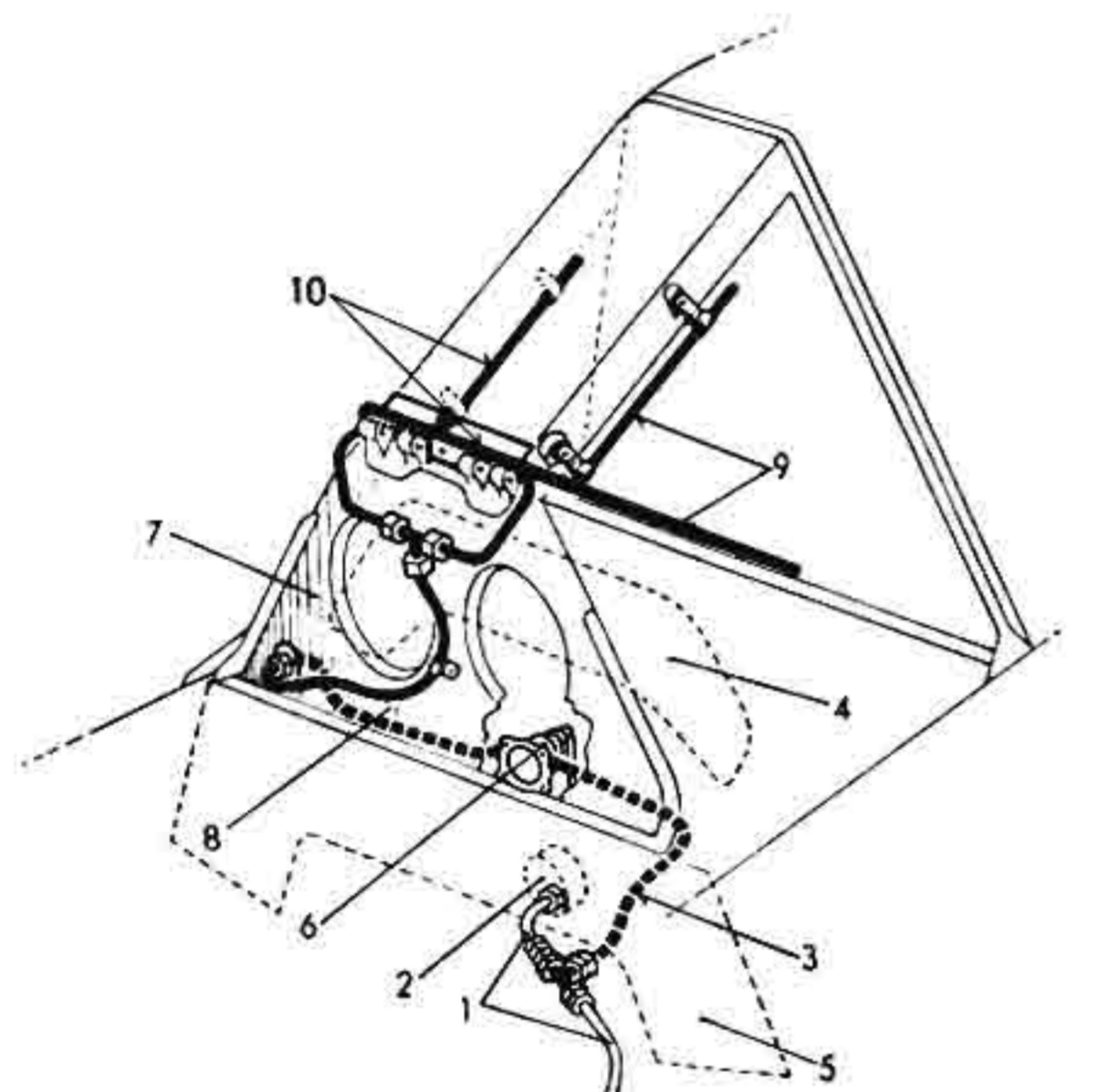

- |                                 |                                     |
|---------------------------------|-------------------------------------|
| 1 Fuel pressure gauge feed line | 6 Windscreen washer operation lever |
| 2 Fuel and oil pressure gauge   | 7 Windscreen mounting frame         |
| 3 Fuel line                     | 8 Fuel line                         |
| 4 Main instrument panel         | 9 Spray tubes                       |
| 5 Auxiliary instrument panel    | 10 Spray tubes                      |

Fig. 17: Windscreen cleaning system

During flight, oil on the front and side window panels can drastically reduce vision through them. These panels can be cleared by spraying fuel over them. The required fuel is drawn from the fuel pressure gauge feed line (17,1). Just before the line enters the gauge (17,2), a tube branches off and runs between the main instrument panel (17,4) and the auxiliary instrument panel (17,5), to a stop cock (17,6) on the windscreen mounting frame (17,7).

D. (Luft) T. 2190 A-8

For Official Use Only!

# **Fw 190 A-8**

Aircraft Handbook

**Part 9B**

**Radio installation**

**(Effective July 1944)**

**Issued September 1944**

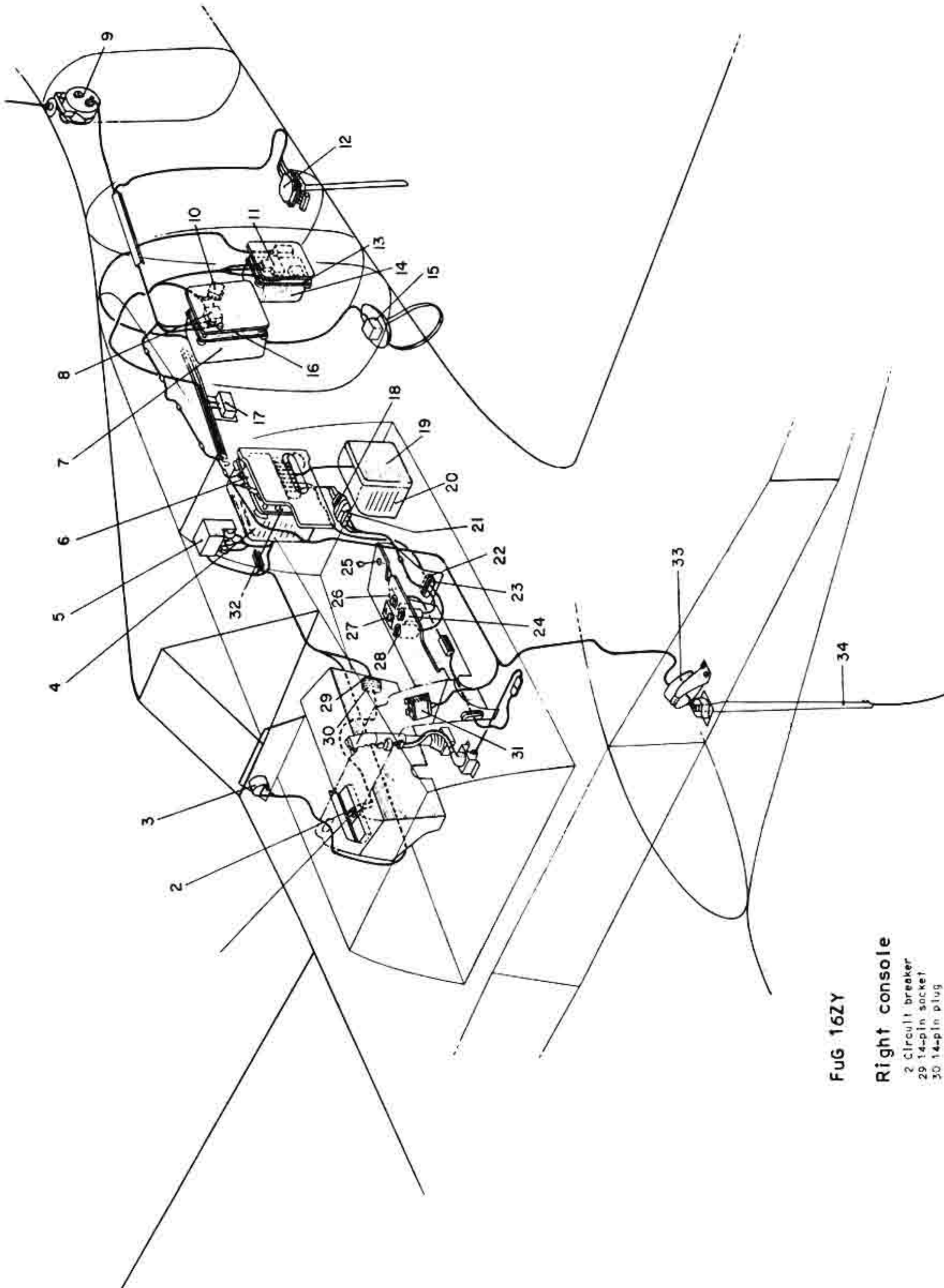

FUG 16ZY

**Right console**

- 2 Circuit breaker
- 29 14-pin socket
- 30 14-pin plug

**Left console**

- 22 20-pin socket
- 23 20-pin plug
- 24 Homing range switch
- 25 Receiver fine tuning switch
- 27 Volume control and FT-ZF switch
- 28 Frequency selector

**Fuselage**

- 3 AFN 2 homing indicator
- 4 Transmitter-receiver unit
- 5 Switcher unit
- 6 Distributor unit
- 9 Antenna matching unit

- 11 Distributor box

- 13 Suspension frame

- 14 Homer bearing converter

- 15 Fixed loop homing antenna

- 17 Junction box

- 18 20-pin socket

- 19 Transformer base plate

- 20 Power transformer

- 21 20-pin plug

- 25 Headset cord attachment point

- 32 Suspension frame

**Left wing**

- 33 Antenna matching unit
- 34 Morane antenna

FUG 25a

**Right console**

- 1 Circuit breaker

**Fuselage**

- 7 Transponder unit
- 8 Distributor box
- 10 Impedance unit
- 12 Antenna matching unit
- 16 Suspension frame
- 31 Control unit





Focke-Wulf  
Aviation  
Corporation  
Bremen

Page:

**Top Secret**

Observe appropriate security regulations

Technical description No. 284

Fw 190 A-8 Fighter

Prepared by: \_\_\_\_\_

30.11.44 Stä/Bu.

File  
Nr. *100*

*Schubert* Issued by



Data sheet

Mission type: Single-seat fighter (Fighter-bomber)

Construction: Single engine, low wing, cantilever construction with electrically retractable undercarriage.

Structural strength: For Fw 190A-8/R2 on fighter operations, at  $G = 4450$  kg (9812.2 lb), safe 'G' factor  $n_A = 6,0$   
On fighter-bomber operations, at  $G = 4775$  kg (10,528.9 lb),  $n_A = 5,5$

Powerplant: BMW 801 D (F 600), from about July 1944 BMW 801 TU

Dimensions:

Wing area	F = 18,3 sq m	(197 sq ft)
Span	b = 10,5 m	(34' 5.4")
Aspect ratio	$b^2/F = 6,0$	
Length	L = 8,95 m	(29' 4.4")
Max. height	H = 3,15 m	(10' 4.0")
Main wheels	700 $\emptyset$ x 175 mm	
Tail wheel	350 $\emptyset$ x 135 mm or 380 $\emptyset$ x 150 mm	

Normal flying weight: Fighter operations  $G = 4400 - 4450$  kg (9702 - 9812.2 lb)  
Fighter-bomber operations  $G = 4775$  kg (10,528.9 lb)

Airframe weight: 1225 kg (2701.1 lb), composed of 55,8% Dural; 36,6% Steel; 4,3% Rubber and plastic; 3,3% Wood

Armament:

Fw 190 A-8: 2 MG 131 in fuselage with 475 rpg  
2 MG 151 in wing-roots with 250 rpg  
2 MG 151 in outer wings with 140 rpg

Fw 190 A-8/R2: 2 MK 108 with 55 rpg replace the outboard MG 151s

Fw 190 A-8/R3: 2 MK 103 with 35 rpg (beneath the wings) replace the outboard MG 151s

Armour:

Engine armour BMW 801 D (F 600)  
Thickness 6,5/5,5 mm; Weight 78,0 kg (171.9 lb)

Engine armour BMW 801 TU  
Thickness 10,0/6,0 mm; Weight 106,0 kg (233.7 lb)

Cockpit armour 60,0 kg (132.3 lb)

Total armour weight 136 or 166 kg (299.8 or 366.0 lb)



Focke-Wulf  
Aviation  
Corporation  
Bremen

Technical description No. 284

Fw 190 A-8 Fighter

Page: 2

Equipment: Fu G 16 ZY; Fu G 25a; Revi 16b

Fuel load: Normal: 525 l (115.5 gal)  
Additional fuselage tank: 115 l (25.3 gal)  
Drop tank: 300 l (66.2 gal)

27.11.44 Stä/Bu.

File  
Nr. *122*

*Hinter* Issued by



Design modifications

The Fw 190 A-8 is the latest production version of the Fw 190 series and includes a number of changes in armament, navigation equipment, range capabilities, etc. designed to meet the demands of modern air warfare. These modifications include:

Fuselage auxiliary tank: Based on the requirement to increase aircraft range without degrading its aerodynamic efficiency, provision has been made for the mounting of a protected fuel tank within the rear fuselage. After August - September 1944 all A-8 aircraft will be delivered with the auxiliary tank fitted. If required, instead of the 115 Ltr (25.3 gal) fuel tank, an unprotected Methanol-water (MW 50) tank of either 115 Ltr (25.3 gal) or 140 Ltr (30.8 gal) capacity, or a GM 1 tank of 85 Ltr (18.7 gal) capacity, can be installed. At the present time, however, it is planned that the standard A-8 will be produced only with the auxiliary fuel tank.

Radio compartment: Fitting of the auxiliary fuel tank has required the relocation of the Fu G 16 radio installation from Bulkhead 8 to the area behind the pilot's seat. An access door built into the fuselage right side provides easy access to the compartment.

Fu G 16 ZY: Fu G 16 ZY radio equipment will be installed in place of the earlier Fu G 16 Z. This set is like the Fu G 16 Z, but has, in addition, the E-type range measuring circuitry. In the interim, Fu G 16 ZE is being fitted; it is equivalent to the Fu G 16 ZY except for its lack of homing capability.

Forward placement of ETC 501: Fitting of the additional fuselage tank has necessitated shifting the ETC 501 (Part no. 8-190.861) forward about 200 mm (7.9 in). Starting with the Fw 190 A-8 series, only the forward mounted ETC 501 (Part no. 8-190.8861) is to be installed. This will be replaced, at a later date, by the aerodynamically and functionally superior ETC 504.

Vertical speed indicator: To improve flight monitoring, a Vertical Speed Indicator will be built into the centre of the main instrument panel.

Camera installation: Starting in June 1944, provision will be made for the installation of a BSK 16 gun camera (Part no. 8-190.8061). The gun camera provides confirmation of gunnery results.

Powerplant: Commencing in July 1944, the BMW 801 D2 (F 600) will be replaced by the BMW 801 TU. This engine is an intermediate step between the BMW 801 D2 (F 600) and the later, more powerful, BMW 801 TS or TH. Due to delays encountered in readying the BMW 801 F for service, the



BMW 801 D will, as a temporary measure, be fitted with certain drive components of the BMW 801 TS/TH; in addition, it will also receive the heavier 10 mm/6 mm armoured nose rings. The BMW 801 TU will be delivered as a complete replacement unit; it is fully interchangeable with the BMW 801 D2 (F 600). With the TS/TH engine installed, the Fw 190 A-8 is re-designated Fw 190 A-9.

Increased emergency power: Commencing in July 1944, all Fw 190 A-8 aircraft will be fitted with the 'emergency power unit'. By overriding the supercharger boost regulator, this system increases the boost pressure, on take-off and emergency power, at the low supercharger setting, from 1,42 ata to 1,58 ata; and at the high supercharger setting, from 1,42 ata to 1,65 ata. The resulting increase in maximum horizontal speed is about 22 km/h (13.6 mph) at the low setting, and about 25 km/h (15.5 mph) at the high setting. Due to the danger of engine overheating, this system must not be used for more than 10 minutes at a time.

GMI installation: The fitting of a GMI unit in place of the additional fuselage fuel tank is basically feasible; but, in the Fw 190 A-8 series is not normally done. It can be used at altitudes above 8 km (26,250 ft) and gives a speed increase of about 58 km/h (36.0 mph) at climb and combat power.

Armament: The normal armament of the Fw 190 A-8 consists of:

- 2 MG 131 in the upper cowling with 475 rpg
- 2 MG 151 in the wing-roots with 250 rpg
- 2 MG 151 in the outer wings with 140 rpg

This armament has been standard commencing with the Fw 190 A-7. Attachment points for a WGR 21 weapons unit beneath each outer wing panel are provided on the A-8.

An armament modification currently in production is the:

- Fw 190 A-8/R2 with MK 108s in the outer wing panels  
with 55 rpg (replacing the outboard MG 151s)

Another armament modification currently in preparation is the:

- Fw 190 A-8/R3 with 2 MK 103s beneath the outer wing panels  
with 35 rpg (replacing the outboard MG 151s)

Fw 190 A-8/R11 Bad weather fighter: A portion of the A-8 production series will, commencing in September 1944, be outfitted as bad weather fighters and will be allocated the designation Fw 190 A-8/R11. Additional equipment will comprise:



- 1.) PKS Course steering unit, with rudder drive installed in the rear fuselage.
- 2.) Window heating: The front and left windscreen panels will be electrically heated.
- 3.) Fu G 125 radio range approach system.

Due to the rearward shift of the Centre of gravity caused by the weight of the steering unit, all Fw 190 A-8/R11 aircraft will be equipped with the heavier BMW 801 TU engine.

The following modifications are, at this time, in the planning stage:

Fw 190 A-8/R7 with increased cockpit armour for use by the Sturmstaffeln (Attack squadrons), with the following armament: 2 MG 131 and 4 MG 151 as per the standard Fw 190 A-8.

Fw 190 A-8/R8 also with increased armour, but with 2 MK 108s in the outer wings as per the Fw 190 A-8/R2.



The Fw 190 A-8 possesses the following armour variations:

Sub-type	Fw 190 A-8 with BMW 801 D2		Fw 190 A-8 with BMW 801 TU		Fw 190 A-8/R8 (Attack fighter)	
	d	G	d	G	d	G
	(mm)	(kg)	(mm)	(kg)	(mm)	(kg)
1. Oil cooler armour	6,5	34,7	10,0	53,3	10,0	53,3
2. Oil tank armour	5,5	43,5	6,0	52,4	6,0	52,4
3. Windscreen mounting unit	-	-	-	-	15,0	16,0
4. Horizontal panel	-	-	-	-	4,0	9,0
5. Windscreen	50,0	14,6	50,0	14,6	50,0	14,6
6. Windscreen side panels	-	-	-	-	30,0	8,0
7. Triangular panels	-	-	-	-	4,0	13,5
8. Seat armour	8,0	18,2	8,0	18,2	8,0	18,2
9. Back armour	5,0	5,9	5,0	5,9	5,0	5,9
10. Panels on Bulkhead 5	5,0	7,9	5,0	7,9	5,0	7,9
11. Head armour	12,0	13,0	12,0	13,0	20,0	20,0
12. MK 108 ammunition front	-	-	-	-	20,0	21,0
13. protection top & bottom	-	-	-	-	4,0	9,0
Total weight of armour		137,8 313.8 lb		165,3 364.5 lb		248,8 548.6 lb

For Attack fighter sub-types of the Fw 190 A-9, the weight of armour is further increased.



# Fw 190A-8 armour

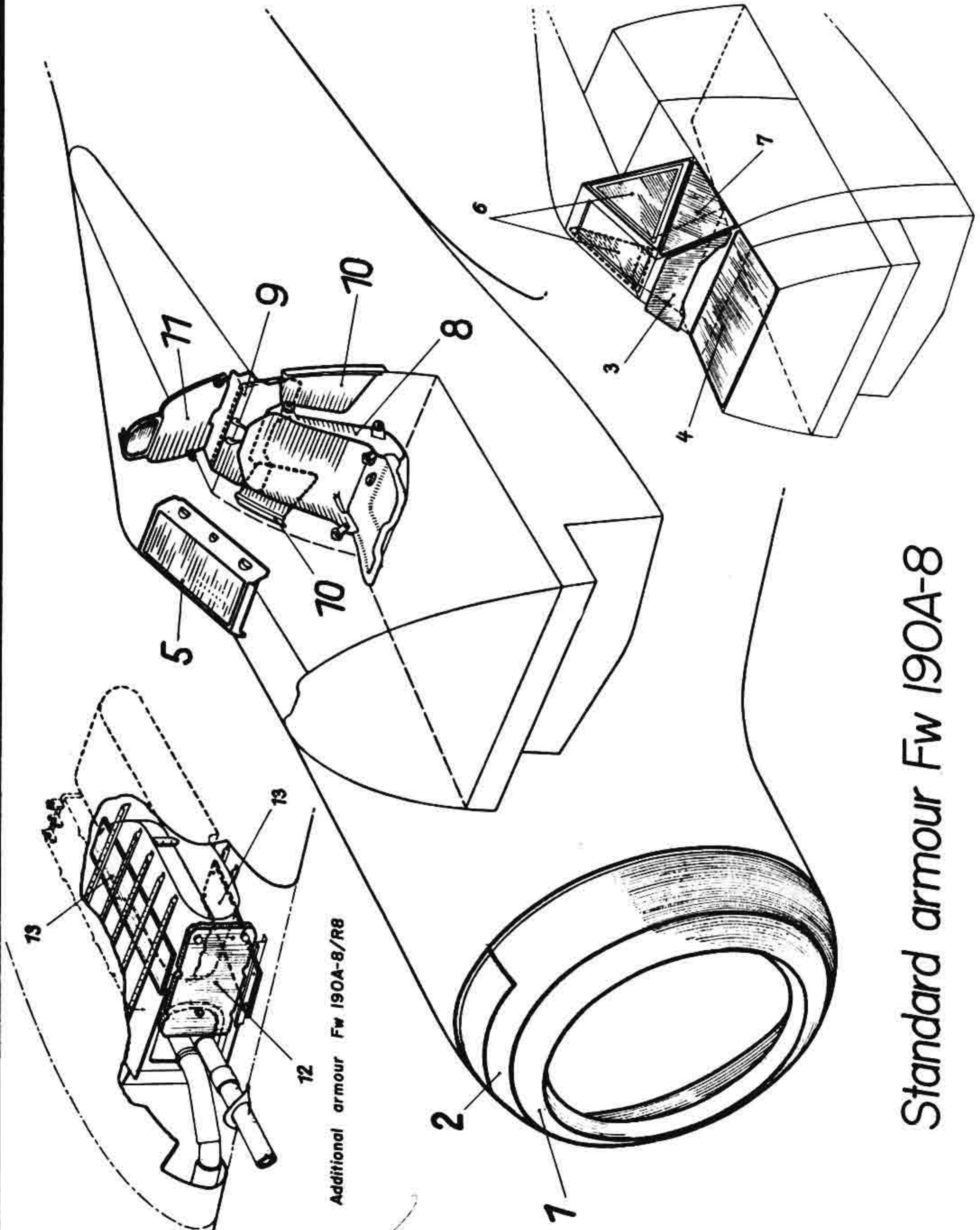

Additional armour Fw 190A-8/R7 & R8

Standard armour Fw 190A-8

Additional armour Fw 190A-8/R8

File Nr. *1000*

*Hemmer*

Issued by





Weight distribution

Fuselage	345,2 kg	761.2 lb
Undercarriage	258,3 "	569.5 "
Control surfaces	120,8 "	266.4 "
Flight controls	32,3 "	71.2 "
Wing assembly	475,0 "	1047.4 "
Powerplant	1661,3 "	3663.2 "
Standard equipment	248,1 "	547.1 "
Permanent accessories	27,4 "	60.4 "
Additional accessories	319,3 "	704.1 "
Paint	2,0 "	4.4 "
<b>Fw 190 A-8 empty weight</b>	<b>3489,7 ~ 3490 kg</b>	<b>7694.8 ~ 7695.4 lb</b>
Pilot, parachute, flying gear	100,0 kg	220.5 lb
Normal fuel 525 l	410,0 "	904.0 "
Auxiliary fuel tank 115 l	90,0 "	198.4 "
Lubricants	50,0 "	110,2 "
Ammunition for MG 131 (2x475 rpg)	77,0 "	169.8 "
Ammunition for MG 151 (2x250 rpg)	110,0 "	242.6 "
Ammunition for MG 151 (2x140 rpg)	64,0 "	141.1 "
<b>Useful load</b>	<b>901,0 kg</b>	<b>1986.6 lb</b>
<b>Empty weight</b>	<b>3490,0 kg</b>	<b>7695.4 lb</b>
<b>1. Fw 190 A-8 flying weight</b>	<b>4391,0 ~ 4400 kg</b>	<b>9682.2 ~ 9702.0 lb</b>
=====		
Removal of 2 MG 151s and ammunition	-176,5 kg	-389.2 lb
2 MK 108 with 55 rpg	240,0 "	529.2 "
<b>2. Fw 190 A-8/R2 flying weight</b>	<b>4454,5 ~ 4450 kg</b>	<b>9822.2 ~ 9812.2 lb</b>
=====		
Removal of 2 MK 108s	-240,0 kg	-529.2 lb
2 MK 103 with 35 rpg	460,0 "	1014.3 "
<b>3. Fw 190 A-8/R3 flying weight</b>	<b>4674,5 ~ 4675 kg</b>	<b>10307.3 ~ 10308.4 lb</b>
=====		
Removal of 2 MK 103s	-460,0 kg	-1014.3 lb
ETC 501 carrier (8861)	60,7 "	133.8 "
SC 500 bomb	500,0 "	1102.5 "
<b>4. Fighter-bomber flying weight</b>	<b>4775,2 ~ 4775 kg</b>	<b>10529.3 ~ 10528.9 lb</b>
=====		

Installation of the BMW 801 TU engine increases the aircraft weight by about 35 kg (77.2 lb).



# Range & Endurance Calculations

Takeoff weight: 4365 kg (9625 lb)

Disposable load: --

Fuel load: 640 Ltr (141 Gal)

**TOP SECRET**

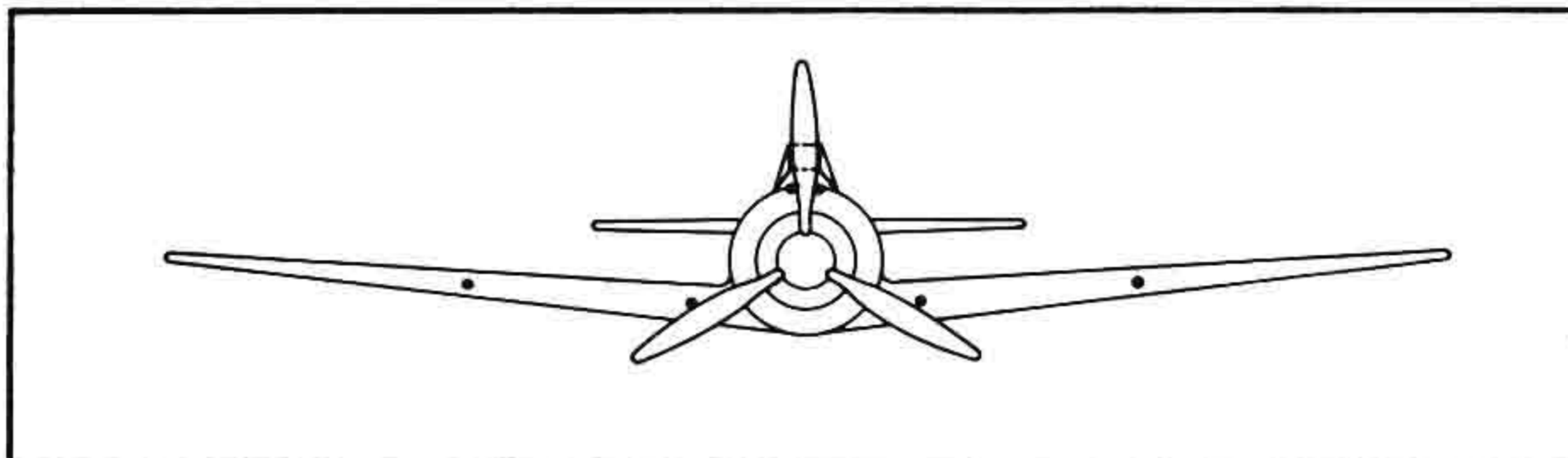

**Status:**

	<b>Fuselage</b>	<b>Wing-roots</b>	<b>Outer wings</b>
<b>Armament</b>	2x MG 131 each 475 rds.	2x MG 151 each 250 rds.	2x MG 151 each 140 rds.
<b>Carrier</b>			
<b>Disposable load</b>			
<b>Fuel load</b>	500 kg (1102 lb)		

Altitude km (ft)	Engine speed rpm	Supercharger pressure		Fuel consumption		Average speed		Flight endurance		Flight distance	
		ata	(psi)	kg/h	(lb/h) <sub>1)</sub>	km/h	(mph) <sub>2)</sub>	h	<sub>3)</sub>	km	(miles) <sub>4)</sub>
0,3 984	2300	1,20	17,0	360	795	515	320	1,20		615	382
	2100	1,10	15,6	225	496	465	289	1,91		885	550
	2000	1,05	14,9	205	452	440	273	2,10		920	572
2,0 6562	2300	1,20	17,0	370	816	550	342	1,28		635	394
	2100	1,10	15,6	240	529	505	314	1,82		890	554
	2000	1,05	14,9	215	474	480	298	2,01		945	587
3,0 9843	2300	1,20	17,0	350	772	540	335	1,30		665	413
	2100	1,10	15,6	240	529	505	314	1,82		885	550
	2000	1,05	14,9	215	474	490	304	2,01		955	594
5,0 16405	2300	1,20	17,0	360	795	575	357	1,32		695	431
	2100	1,10	15,6	240	529	535	332	1,84		925	575
	2000	1,05	14,9	215	474	510	317	2,02		985	612
7,0 22967	2300	1,20	17,0	325	716	580	360	1,48		775	481
	2100	1,10	15,6	220	485	530	329	1,98		990	616
	2000	1,05	14,9	195	430	495	308	2,18		1035	644

**Notes:**

- 1) Consumption from BMW specifications + 12.5% reserve
  - 2) Average speed = arithmetic average of outbound and inbound legs
  - 3) Endurance includes climb and descent times
  - 4) Range calculated without deductions for tactical requirements! Includes climb and descent distances
- Deductions have been made for warmup, taxi, takeoff, climb, descent, overshoot and reserves

Date 23.12.43

Compiled by *Jansen*  
*Vaigto Lorenz*



# Range & Endurance Calculations

Takeoff weight: 4480 kg (9866 lb)  
 Disposable load: WR 21  
 Fuel load: 640 Ltr (141 Gal)

**TOP SECRET**

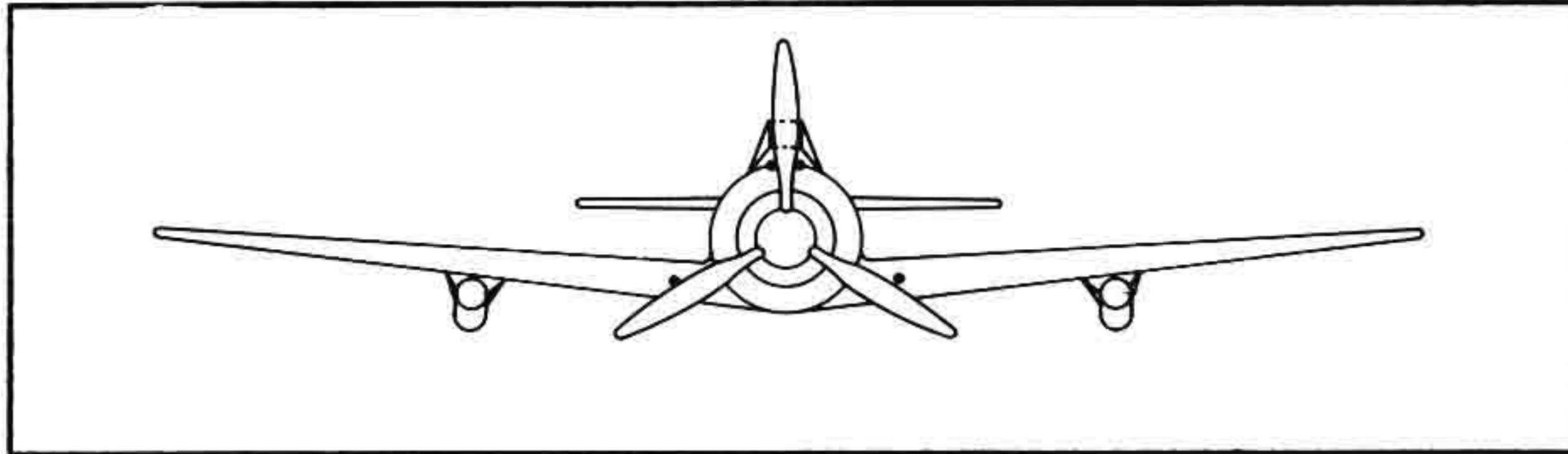

<b>Status:</b>	<b>Fuselage</b>	<b>Wing-roots</b>	<b>Outer wings</b>
<b>Armament</b>	2x MG 131 each 475 rds.	2x MG 151 each 250 rds.	2x WR 21
<b>Carrier</b>			
<b>Disposable load</b>	WR 21		
<b>Fuel load</b>	500 kg (1102 lb)		

Altitude km (ft)	Engine speed rpm	Supercharger pressure		Fuel consumption		Average speed		Flight endurance		Flight distance	
		ata	(psi)	kg/h	(lb/h) <sub>1)</sub>	km/h	(mph) <sub>2)</sub>	h	<sub>3)</sub>	km	(miles) <sub>4)</sub>
0,3 984	2300	1,20	17,0	360	795	470	292	1,20		565	351
	2100	1,10	15,6	225	496	425	264	1,91		810	503
	2000	1,05	14,9	205	452	400	249	2,10		845	525
2,0 6562	2300	1,20	17,0	370	816	500	311	1,22		585	363
	2100	1,10	15,6	240	529	460	286	1,81		815	506
	2000	1,05	14,9	215	474	440	273	2,01		865	538
3,0 9843	2300	1,20	17,0	350	772	495	308	1,30		610	379
	2100	1,10	15,6	240	529	460	286	1,82		805	500
	2000	1,05	14,9	215	474	445	276	2,01		865	538
5,0 16405	2300	1,20	17,0	360	795	527	328	1,31		630	391
	2100	1,10	15,6	240	529	490	304	1,81		840	522
	2000	1,05	14,9	215	474	465	289	1,99		885	550
7,0 22967	2300	1,20	17,0	325	716	525	327	1,44		685	425
	2100	1,10	15,6	220	485	475	295	1,92		860	535
	2000	1,05	14,9	195	430	435	270	2,11		885	550

**Notes:**

- 1) Consumption from BMW specifications + 12.5% reserve
- 2) Average speed = arithmetic average of outbound and inbound legs
- 3) Endurance includes climb and descent times
- 4) Range calculated without deductions for tactical requirements! Includes climb and descent distances  
 Deductions have been made for warmup, taxi, takeoff, climb, descent, overshoot and reserves

Date 23.12.43

Compiled by Jansen  
Veisbacher



# Range & Endurance Calculations

Takeoff weight: 4683 kg (10326 lb)  
 Disposable load: 300 Ltr (66.2 Gal) drop tank  
 Fuel load: 940 Ltr (207 Gal)

**TOP SECRET**

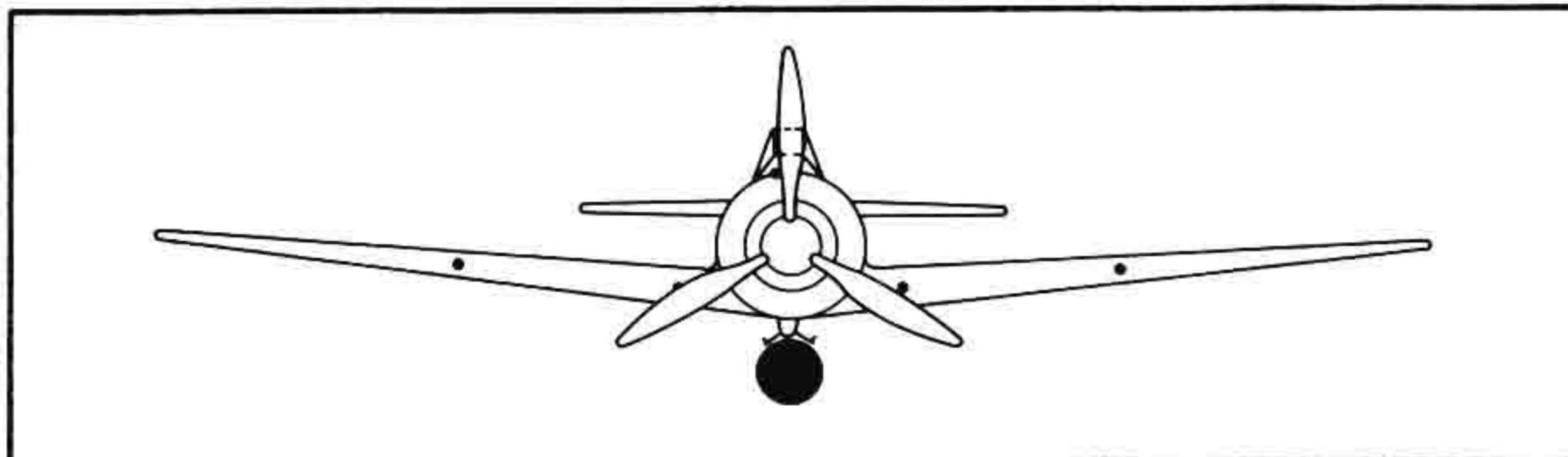

<b>Status:</b>	<b>Fuselage</b>	<b>Wing-roots</b>	<b>Outer wings</b>
<b>Armament</b>	2x MG 131 each 475 rds.	2x MG 151 each 250 rds.	2x MG 151 each 140 rds.
<b>Carrier</b>	ETC 501		
<b>Disposable load</b>	300 l (66,2 gal) drop tank		
<b>Fuel load</b>	734 kg (1618 lb)		

Altitude km (ft)	Engine speed rpm	Supercharger pressure		Fuel consumption		Average speed		Flight endurance		Flight distance	
		ata	(psi)	kg/h	(lb/h) <sub>1)</sub>	km/h	(mph) <sub>2)</sub>	h	<sub>3)</sub>	km	(miles) <sub>4)</sub>
0,3 984	2300	1,20	17,0	360	795	490	304	1,85		915	569
	2100	1,10	15,6	225	496	440	273	2,95		1310	816
	2000	1,05	14,9	205	452	415	258	3,24		1370	852
2,0 6562	2300	1,20	17,0	370	816	520	323	1,86		950	590
	2100	1,10	15,6	240	529	475	295	2,79		1325	825
	2000	1,05	14,9	215	474	455	282	3,10		1415	880
3,0 9843	2300	1,20	17,0	350	772	515	320	1,98		990	616
	2100	1,10	15,6	240	529	480	298	2,80		1325	825
	2000	1,05	14,9	215	474	460	286	3,10		1420	884
5,0 16405	2300	1,20	17,0	360	795	545	338	1,97		1025	637
	2100	1,10	15,6	240	529	505	314	2,79		1375	856
	2000	1,05	14,9	215	474	485	301	3,10		1470	915

**Notes:**

- 1) Consumption from BMW specifications + 12.5% reserve
  - 2) Average speed = arithmetic average of outbound and inbound legs
  - 3) Endurance includes climb and descent times
  - 4) Range calculated without deductions for tactical requirements! Includes climb and descent distances
- Deductions have been made for warmup, taxi, takeoff, climb, descent, overshoot and reserves

Date 23.12.43

Compiled by Jansen  
Voigtlinger



# Range & Endurance Calculations

Takeoff weight: 4923 kg (10855 lb)  
 Disposable load: SC 500  
 Fuel load: 640 Ltr (141 Gal)

**TOP SECRET**

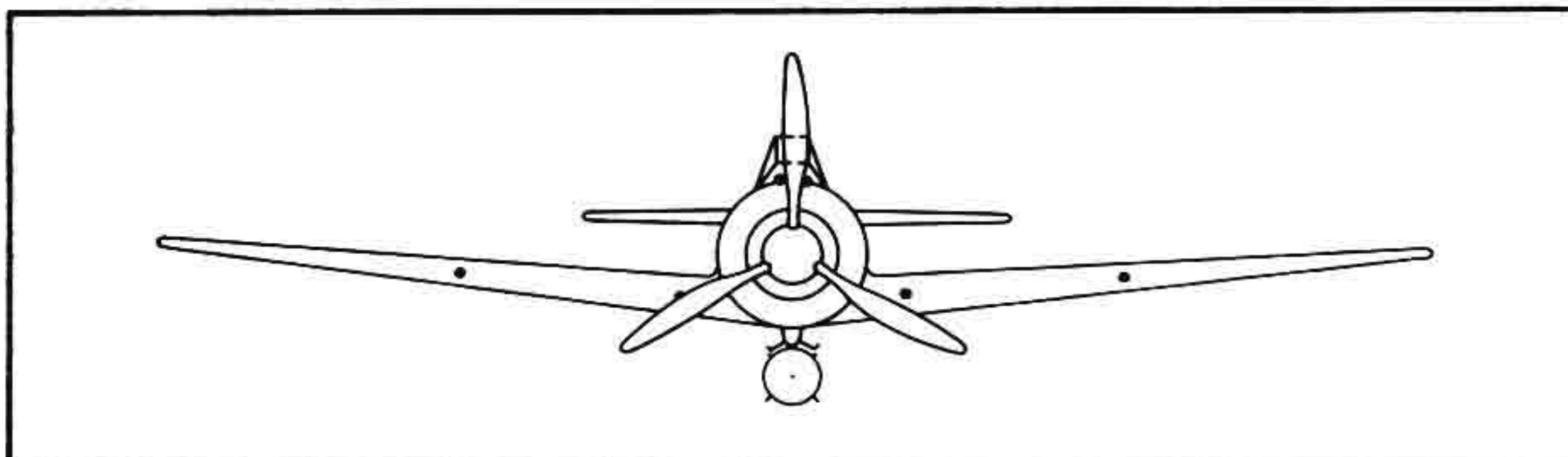

<b>Status:</b>	<b>Fuselage</b>	<b>Wing-roots</b>	<b>Outer wings</b>
<b>Armament</b>	2x MG 131 each 475 rds.	2x MG 151 each 250 rds.	2x MG 151 each 140 rds.
<b>Carrier</b>	ETC 501		
<b>Disposable load</b>	SC 500		
<b>Fuel load</b>	500 kg (1102 lb)		

Altitude km (ft)	Engine speed rpm	Supercharger pressure		Fuel consumption		Average speed		Flight endurance h	Flight distance	
		ata	(psi)	kg/h	(lb/h) <sub>1)</sub>	km/h	(mph) <sub>2)</sub>		km	(miles) <sub>4)</sub>
0,3 984	2300	1,20	17,0	360	795	485	301	1,20	575	357
	2100	1,10	15,6	225	496	430	267	1,91	825	513
	2000	1,05	14,9	205	452	410	255	2,10	860	535
2,0 6562	2300	1,20	17,0	370	816	515	320	1,21	590	366
	2100	1,10	15,6	240	529	470	292	1,79	815	506
	2000	1,05	14,9	215	474	450	280	2,00	870	546
3,0 9843	2300	1,20	17,0	350	772	510	317	1,28	610	379
	2100	1,10	15,6	240	529	470	292	1,78	805	500
	2000	1,05	14,9	215	474	455	282	1,96	860	535
5,0 16405	2300	1,20	17,0	360	795	540	335	1,29	630	391
	2100	1,10	15,6	240	529	500	311	1,77	830	516
	2000	1,05	14,9	215	474	475	295	1,94	875	544

**Notes:**

- 1) Consumption from BMW specifications + 12.5% reserve
  - 2) Average speed = arithmetic average of outbound and inbound legs
  - 3) Endurance includes climb and descent times
  - 4) Range calculated without deductions for tactical requirements! Includes climb and descent distances
- Deductions have been made for warmup, taxi, takeoff, climb, descent, overshoot and reserves

Date 23.12.43

Compiled by *Janssen*  
*Veitberger*

hp Ps

# BMW 801D

Performance curve  
from BMW Sh.Nr. 9-801:5401 of  
10.7.42

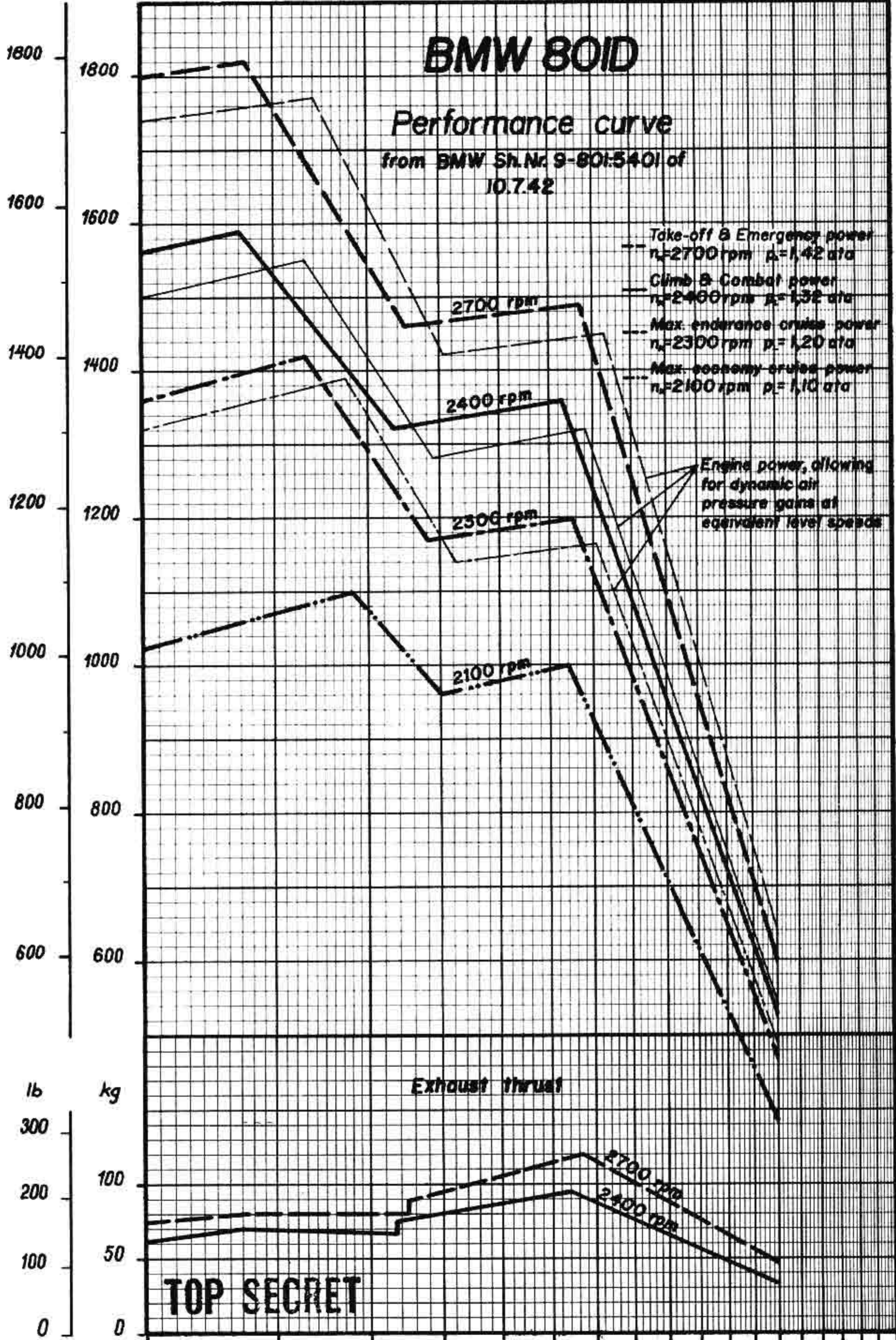

- Take-off & Emergency power  
n=2700rpm p=1.42 ata
- Climb & Combat power  
n=2400rpm p=1.32 ata
- Max. endurance cruise power  
n=2300rpm p=1.20 ata
- Max. economy cruise power  
n=2100rpm p=1.10 ata

Engine power, allowing for dynamic air pressure gains at equivalent level speeds

## Exhaust thrust

lb kg

TOP SECRET

0 1 2 3 4 5 6 7 8 10 12 14 16 18 km  
0 5 10 15 20 25 30 35 40 45 50 55 ft(x1000)

11.09.44

6ii.



**TOP SECRET**

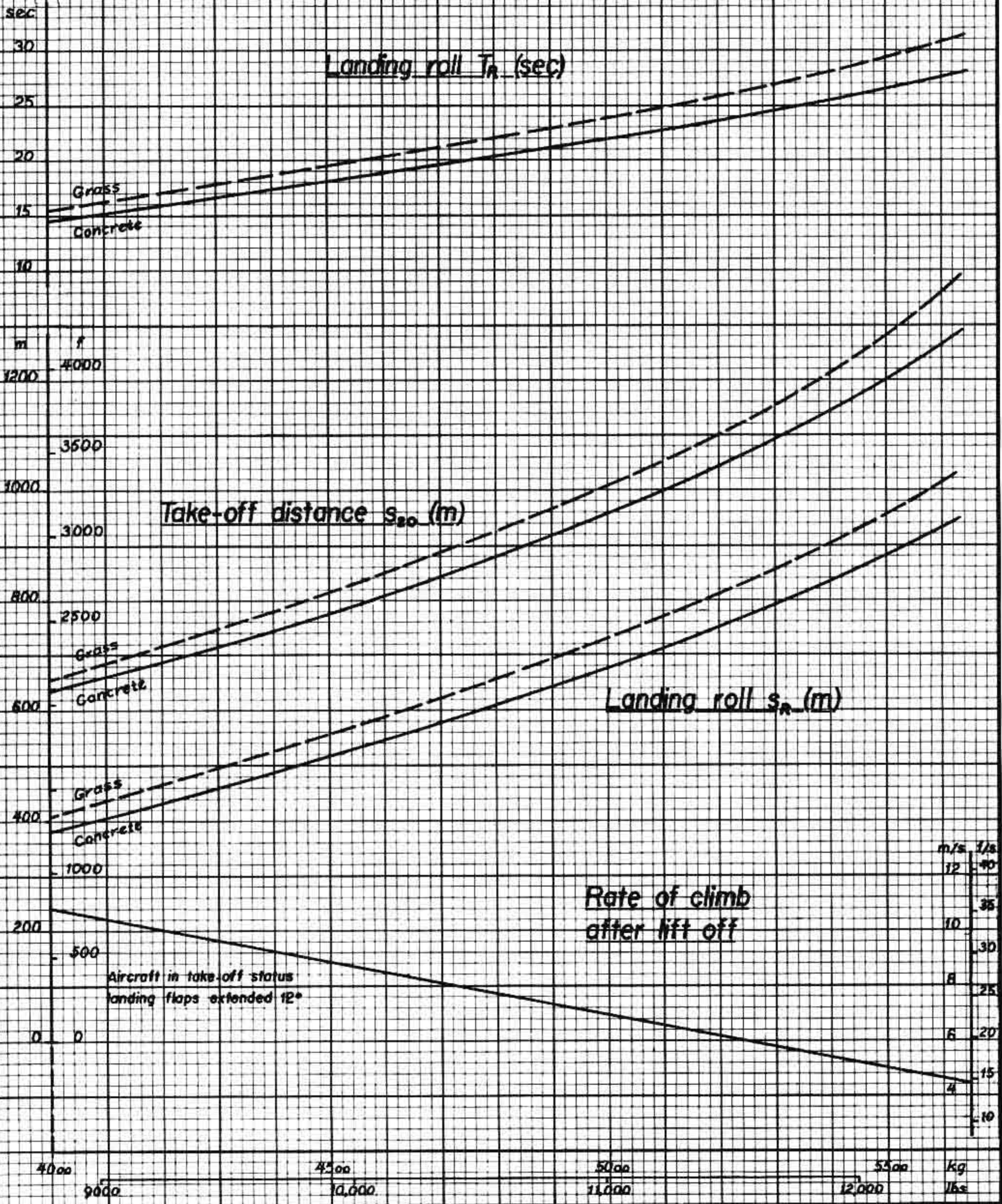



# Landing speed

## Fw 190A-8 Fighter

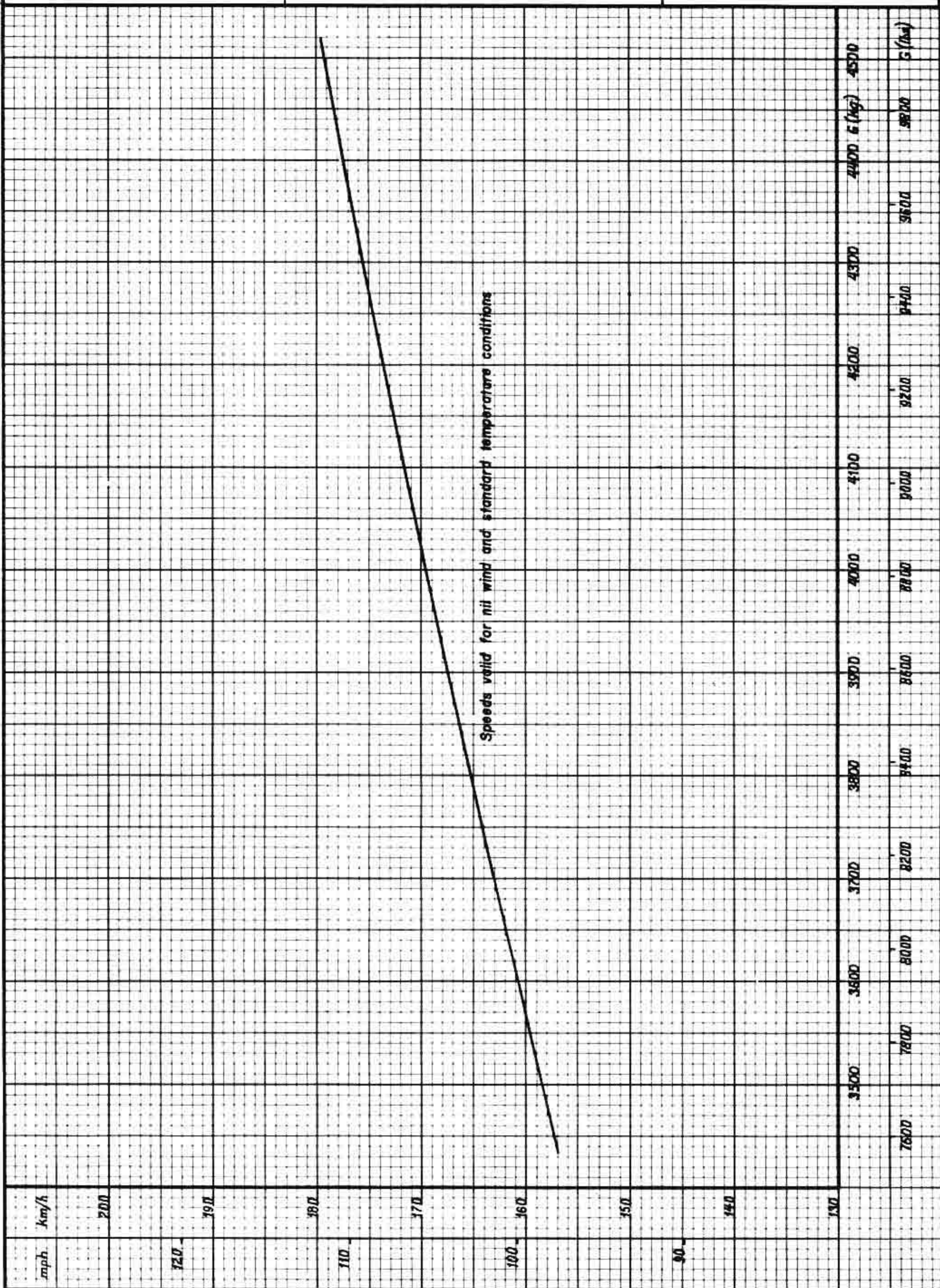

Speeds valid for nil wind and standard temperature conditions





# Flight performance

# Fw 190A-8 Fighter

Curve Nr.	Aircraft type	Flying weight	Engine	Power setting	n (rpm)	R	Status		
							Armament	Fuselage	Wing-roots
1	Fw 190	4300 kg 9481 lb	BMW 801D	Take-off and emergency power	2700	1,42 ata 20.2 psi	2 x MG 131 2 x 475 rds	2 x MG 151 2 x 250 rds	2 x MG 151 2 x 140 rds
2				Climb and combat power	2400	1,32 ata 18.7 psi	Fuel: 525 Ltr (115.5 Gal) + 115 Ltr (25.3 Gal) in rear fuselage Without ETC 501		
3				Maximum endurance cruise	2300	1,20 ata 17.0 psi	Undercarriage: Wheel doors fitted RT: FuG 16ZY External surfaces: Filled + polished		

TOP SECRET

## Climbing speeds

Climb times (min)	Climb times to altitude (km)	(ft)
5	18,586	22,967
6	11,4	14,4
7	9,2	11,4
8	6,6	8,6
9	2,5	2,6

a)  $n_1 = 2400$  rpm  $R_1 = 1,32$  ata  
 b)  $n_2 = 2700$  rpm  $R_2 = 1,42$  ata  
 c)  $n_3 = 2700$  rpm  $R_3 = 1,58/1,65$  ata  
 at  $(m/h) = 1,0$

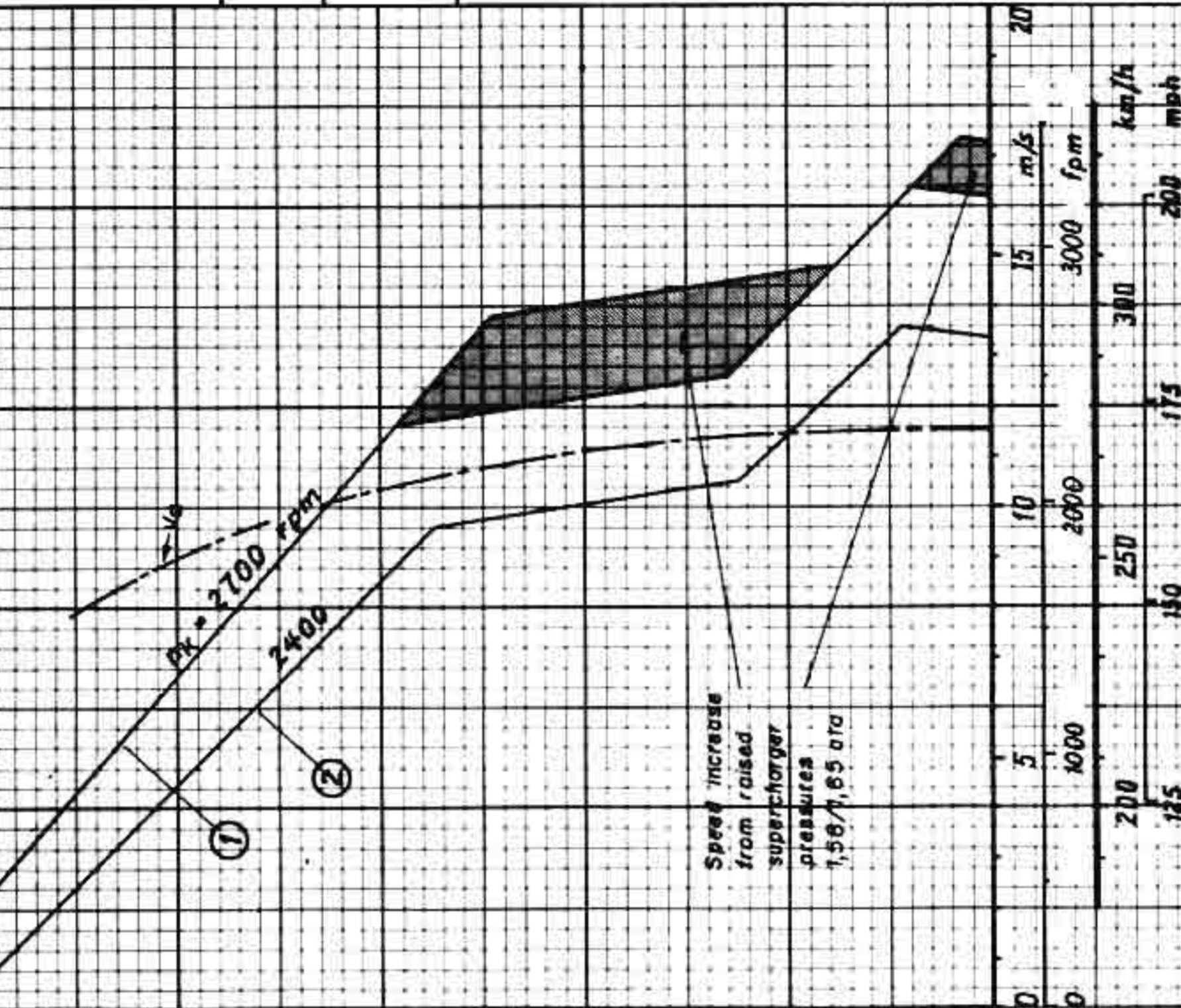

## Horizontal top speeds

Speed loss with ETC 501

$M=0$  km -  $AV = 12$  km/h (7,5 mph)  
 $M=6$  km -  $AV = 16$  km/h (10,0 mph)

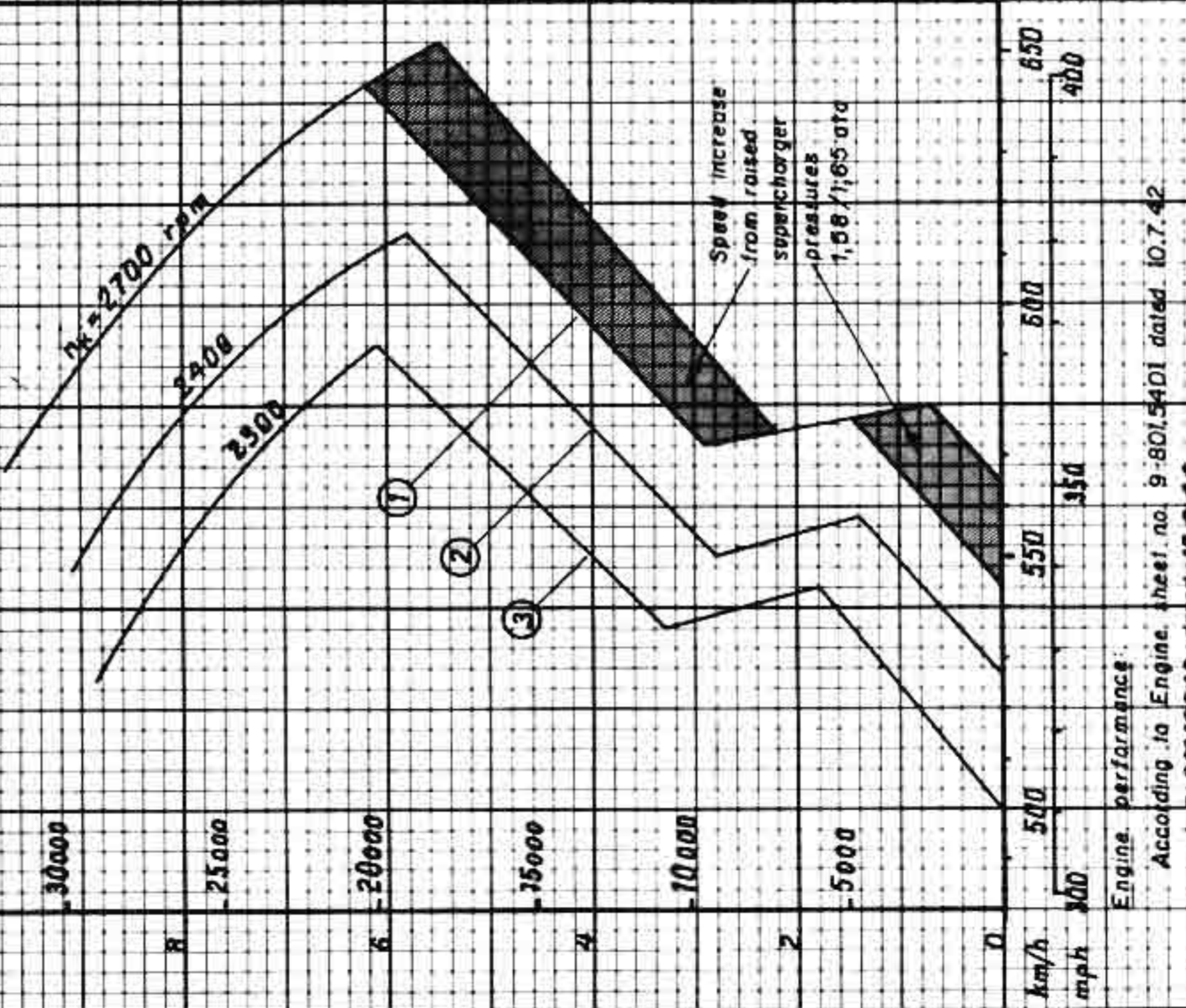

Engine performance:  
 According to Engine sheet no. 9-801,5401 dated 10.7.42  
 and 9-801,10242 dated 15.8.44



Curve Nr.	Aircraft type	Flying weight	Engine	Power setting	n (rpm)	P <sub>r</sub>	Status		
							Armament	Fuselage	Wing-roots
1	Fw 190	4300 kg 9481 lb	BMW 801D	Take-off and emergency power	2700	1,42 ata 20.2 psi	2x MG 131 2x 475 rds	2x MG 151 2x 250 rds	2x MG 151 2x 140 rds
2				Climb and combat power	2400	1,32 ata 18.7 psi	Fuel: 525 Ltr (115.5 Gal) + GM1 system Without ETC 501		
3				Maximum endurance cruise	2300	1,20 ata 17.0 psi	Undercarriage: Wheel doors fitted RT: FuG 16ZY External surfaces: Filled + polished		

TOP SECRET

### Climbing speeds

Climb times (min)	8	9	10	11
Climb to altitude (km)	26,248	29,529	32,810	36,091
(ft)	74,4	76,5	79,5	82,2
0) n <sub>h</sub> = 2400 rpm P <sub>r</sub> = 1,32 ata	10,7	13,2	15,4	17,4
1) n <sub>h</sub> = 2700 rpm P <sub>r</sub> = 1,587/18,5 ata	10,1	12,4	14,4	16,4

### Horizontal speeds

Speed loss with ETC 501  
 $H=0 \text{ km} - AV=12 \text{ km/h} (7.5 \text{ mph})$   
 $H=8 \text{ km} - AV=15 \text{ km/h} (9.3 \text{ mph})$

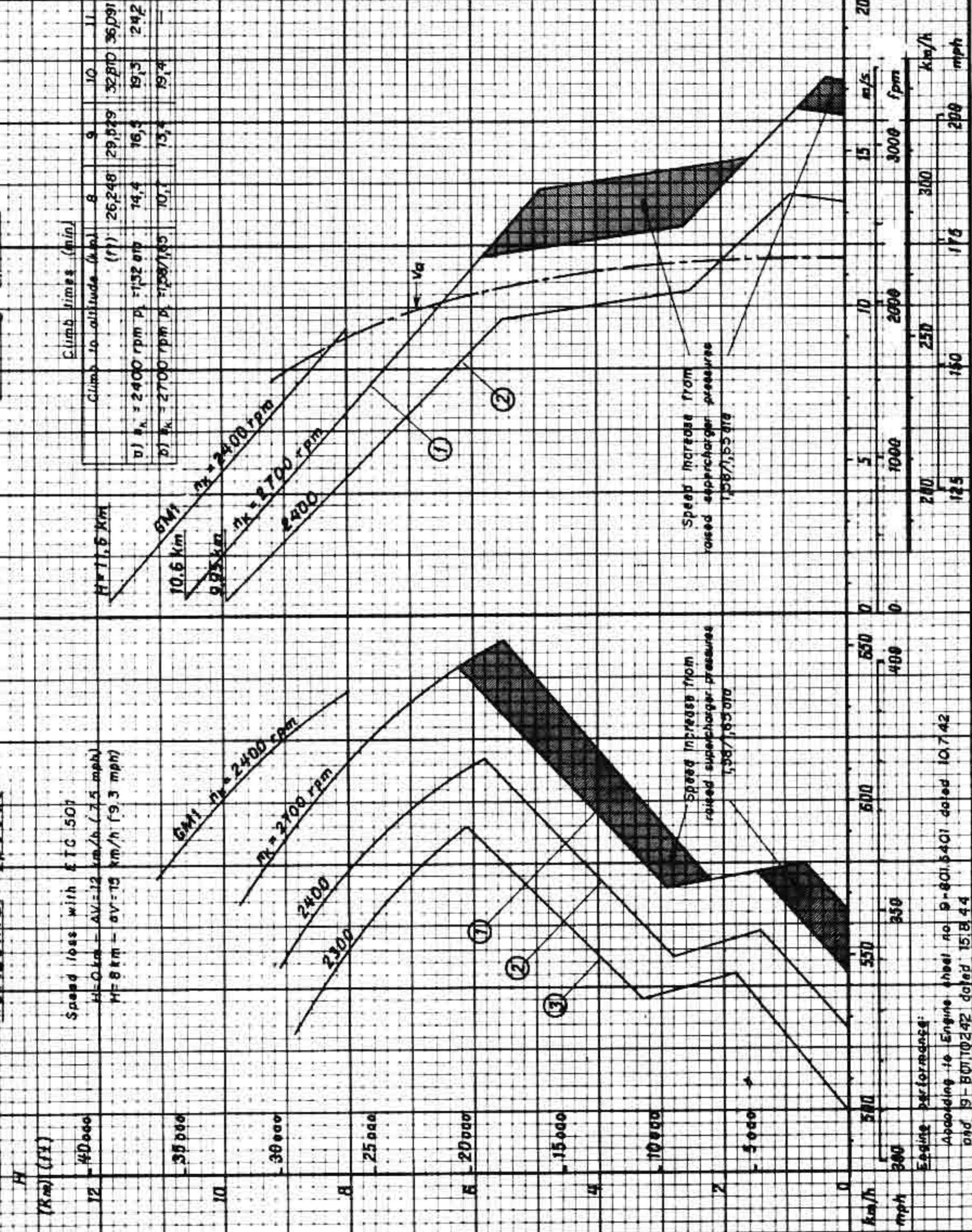

Engine performance:  
 According to Engine sheet no. 9-801.5401 dated 10.7.42  
 and 9-801.10242 dated 15.8.44



Curve Nr.	Aircraft type	Flying weight	Engine	Power setting	n (rpm)	P	Status		
							Armament	Fuselage	Wing-roots
1	Fw 190	4300 kg 9481 lb	BMW 801D	Take-off and emergency power	2700	1,42 ata 20.2 psi	2 x MG 131 2 x 475 rds	2 x MG 151 2 x 250 rds	2 x MK 108 2 x 55 rds
2				Climb and combat power	2400	1,32 ata 18.7 psi	Fuel: 525 Ltr (115.5 Gal) + 115 Ltr (25.3 Gal) in rear fuselage Without ETC 501 Undercarriage: Wheel doors fitted RT: FuG 16ZY External surfaces: Filled + polished		
3				Maximum endurance cruise	2300	1,20 ata 17.0 psi			

**TOP SECRET**

**Climbing speeds**

Climb time (min)		Climb to altitude (km)		Climb to altitude (ft)	
a)	$n_e = 2400$ rpm	$P_e = 1,32$ ata	9,6	11,8	15,7
b)	$n_e = 2700$ rpm	$P_e = 1,42$ ata	7,8	9,5	11,8
c)	$n_e = 2700$ rpm	$P_e = 1,58/1,65$	7,1	8,8	11,0
$\Delta T$ (min)		3,5		3,0	
$\Delta T$ (min)		4,7		4,3	

**Horizontal speeds**

Speed loss with ETC 501  
 $MFO_{max} = 207,2$  km/h (175 mph)  
 $MFO = 5$  km =  $\Delta V = 15$  km/h (9,3 mph)

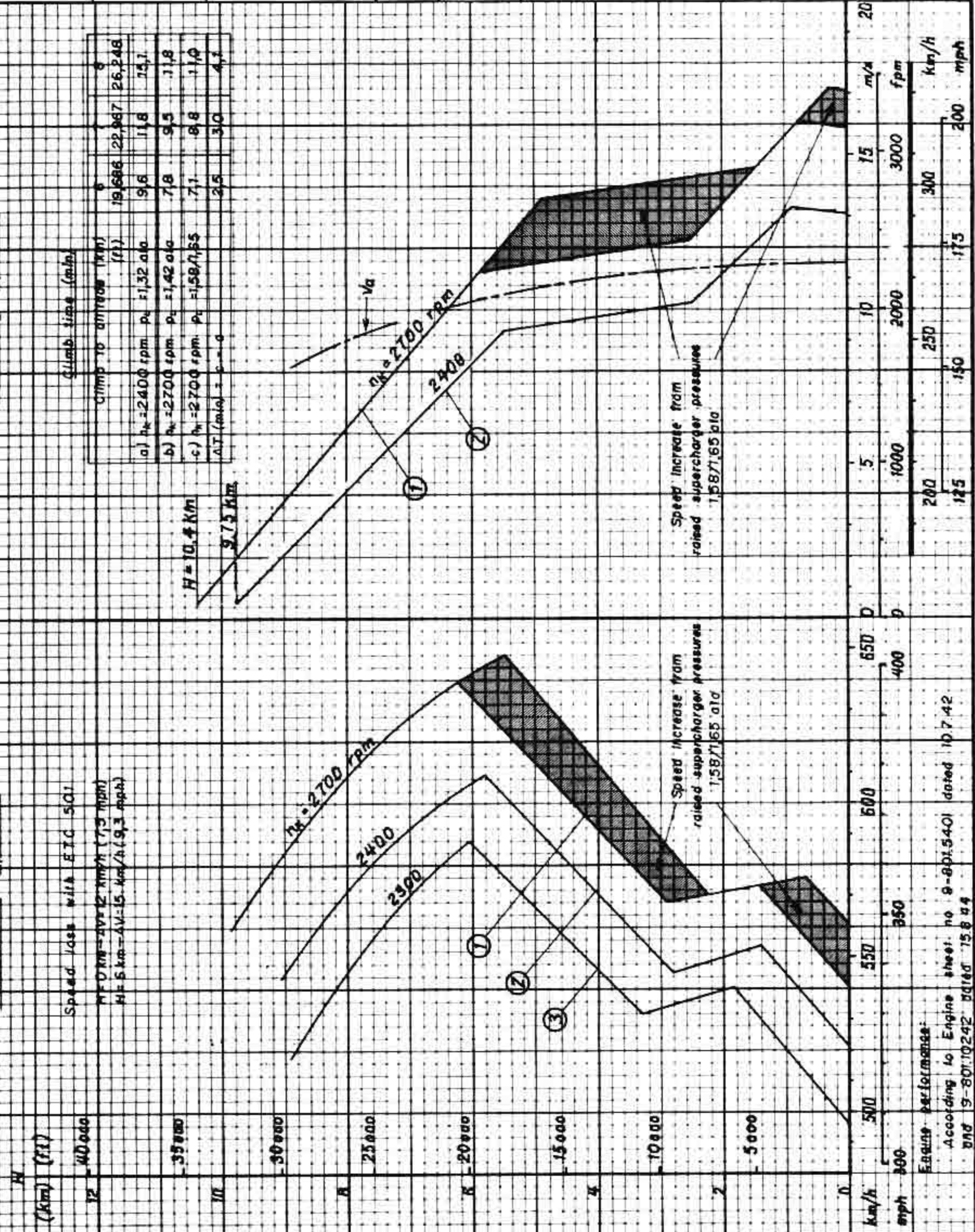

Engine performance:  
According to Engine sheet no 9-801.5401 dated 10.7.42  
and 9-801.0242 dated 15.8.44